

Gas Industry Standard

GIS/E22:2006

Specification for

**Vehicle-mounted leakage survey equipment —
Minimum performance and maintenance requirements
for equipment used for winter and trigger surveys**



Contents

	Page
Foreword	iii
Mandatory and non-mandatory requirements	iii
Disclaimer	iii
Brief history	iv
1 Scope	1
2 Normative references	1
3 Terms and definitions	1
4 General design principles	1
5 Design of vehicle and equipment	2
5.1 General	2
5.2 Vehicle	2
5.3 Sample collection and treatment	2
5.4 Detection system	3
5.5 Electrical power supply equipment	3
5.6 Display equipment	3
6 Overall performance of the complete equipment	4
7 Environmental conditions	4
8 Safety	4
9 Installation of pipe work	4
10 Maintenance	4
11 Marking	5
Annex A (normative) Test procedures (for continuous pumped flame ionization measurement system)	6
Annex B (informative) Recommendations for using carbon absorbers	9
Figure B.1 — Schematic of carbon absorber	10
Figure B.2 — Circuit diagram – typical drift alarm unit	10

Foreword

Gas Industry Standards (GIS) are revised, when necessary, by the issue of new editions. Users should ensure that they are in possession of the latest edition. Contractors and other users external to Gas Transporters should direct their requests for copies of a GIS to the department or group responsible for the initial issue of their contract documentation.

Comments and queries regarding the technical content of this document should be directed in the first instance to the contract department of the Gas Transporter responsible for the initial issue of their contract documentation.

This standard calls for the use of procedures that may be injurious to health if adequate precautions are not taken. It refers only to technical suitability and does not absolve the user from legal obligations relating to health and safety at any stage.

Compliance with this engineering document does not confer immunity from prosecution for breach of statutory or other legal obligations.

Mandatory and non-mandatory requirements

For the purposes of a GIS the following auxiliary verbs have the meanings indicated:

- can** indicates a physical possibility;
- may** indicates an option that is not mandatory;
- shall** indicates a GIS requirement;
- should** indicates best practice and is the preferred option. If an alternative method is used then a suitable and sufficient risk assessment needs to be completed to show that the alternative method delivers the same, or better, level of protection.

Disclaimer

This engineering document is provided for use by Gas Transporters and such of their contractors as are obliged by the terms of their contracts to comply with this engineering document. Where this engineering document is used by any other party, it is the responsibility of that party to ensure that the engineering document is correctly applied.

Brief history

First published as Draft E22 Parts 1 and 2 Editorial update to reflect demerger November 2000 Editorial update to reflect merger October 2002 Editorial update to comply with GRM Edited by BSI in accordance with BS 0-3:1997 Reviewed on behalf of the Gas Distribution Networks' Technical Standard Forum by BSI Reviewed by TSF Reviewed by TSF	February 1992 June 2001 November 2002 August 2004 August 2006 September 2013 June 2018 July 2023
--	---

© Energy Networks Association on behalf of Cadent Gas Limited, Northern Gas Networks, SGN and Wales & West Utilities Ltd.

This Gas Industry Standard is copyright and must not be reproduced in whole or in part by any means without the approval in writing of Energy Networks Association.

1 Scope

This Gas Industry Standard defines the minimum performance and maintenance requirements for vehicle-mounted leakage survey equipment used for winter and trigger surveys (as defined in **/PL/LC/18, Management procedure for Leakage Survey*). Although this standard does not refer to any particular design of equipment, it is applicable to all vehicles and equipment used for winter and trigger surveys.

2 Normative references

The following referenced documents are indispensable for the application of this document. For dated references, only the edition cited applies. For undated references, the latest edition of the referenced document (including any amendments) applies.

Individual Gas Distribution Network Standards

**/PM/LC/18, Management procedure for leakage survey.*

* = Denotes each gas distribution network reference

3 Terms and definitions

For the purposes of this standard the following terms and definitions apply.

3.1

detector

gas detector capable of responding to the presence of methane in air and providing, via both visual and electrical outputs, a measure of methane concentration

3.2

overall system dilution (OSD)

ratio of the gas cloud concentration to the peak gas concentration subsequently measured by the detector, when one quarter of the sample inlet points traverses a gas cloud in 0.5 s

NOTE When a sample inlet transiently traverses a gas cloud, the sampled gas mixes with the air entering sample inlets not in the cloud, and with the air preceding and following the gaseous sample as it passes through the pipework of the detector. The peak gas concentration arriving at the detector is generally less than the cloud concentration. This dilution effect is quantified by the OSD.

3.3

delay time

time taken from encountering a gas cloud to the output signal of the detector reaching a maximum

3.4

signal threshold

adjustable setting by which all indications of gas leakage below a nominated level are rejected

3.5

Winter and Trigger surveys

defined in **/PL/LC/18, Management procedure for leakage survey*

4 General design principles

4.1 Winter and Trigger surveys shall be carried out using equipment conforming to this standard set to detect the gas cloud concentration specified in **/PM/LC/18*.

4.2 The performance of all equipment shall be within the limits specified in this standard and shall be capable of continuous operation for a minimum of 8 h.

4.3 All equipment shall operate within the requirements of this standard at vehicle speeds below 30 km/h. Allowance shall be made for expected vehicle vibrations.

4.4 All equipment shall be designed to operate within the requirements of this standard for a minimum of 6 months.

4.5 The sample collection system, detection equipment and any designated optional equipment may be designed so as to be detachable for transfer to other vehicles.

5 Design of vehicle and equipment

5.1 General

5.1.1 The vehicle complete with equipment shall be capable of safe operation so that any undue hazards to either the public or to the operator(s) shall be avoided during survey.

5.1.2 All equipment shall be located securely in the vehicle and, where necessary, screened from any source of electrical interference.

5.1.3 The detector shall be easily removable for use as a portable instrument.

5.1.4 The equipment shall be positioned so as not to distract or impair the driver.

5.2 Vehicle

5.2.1 Any modification to the vehicle, required for the installation of the equipment, shall conform to current regulations for construction and use.

5.2.2 Reflected or illuminated warning sign(s) bearing the legend(s) "SURVEYING" and/or "SLOW VEHICLE" shall be attached to the vehicle.

5.2.3 One amber rotating hazard warning lamp shall be mounted externally on the vehicle roof as required by SI 1989 No. 1796.

5.3 Sample collection and treatment

5.3.1 The sample collection and treatment equipment shall be capable of collecting a representative sample of the atmosphere traversed by the vehicle and of transmitting the sample to the detection equipment.

5.3.2 The pumped sample collection system shall be in accordance with the following.

- a) A minimum of 4 inlet points spread evenly across the full width of the vehicle.
- b) Inlet point flow shall not vary by more than $\pm 10\%$ across the sample collection system.
- c) Inlet points shall be positioned level, i.e. 50 mm to 100 mm height from the ground and not more than 300 mm in front of the vehicle. Inlet points shall not project beyond the width of the vehicle.
- d) A positive displacement pump (powered by the vehicle) capable of continuously sampling the atmosphere shall be installed in the sample collection system.

5.3.3 An adjustable or suitably dimensioned vent shall be installed into the pipework between the pump and detection instrument. The purpose of the vent is to minimize pressurization of the detector and remove excess flow.

5.3.4 Filters and water traps shall be incorporated in the sample collection system line between the inlet points and the pump to protect the detection equipment from damage or failure. Such filters and water traps shall be readily accessible for maintenance.

5.3.5 The sample collection system line may incorporate a device to minimize the response of the detector to non-methane hydrocarbons. Where the device consists of a carbon absorber, the recommendations in Annex B shall be taken into account.

5.4 Detection system

5.4.1 The sample shall be analysed by a detector capable of responding to the presence of methane in air concentrations of 1 ppm by volume. The upper limit of detection shall be not less than 500 ppm. The detector shall satisfy the following requirements over the full range of environmental conditions specified in Clause 7.

- a) For an input of 0 ppm to 500 ppm, the detector shall produce an electrical output that increases in a predictable manner with gas concentration. The calibration shall be repeatable within $\pm 5\%$ of the output or the equivalent of ± 2 ppm, whichever is the greater.
- b) The intrinsic zero stability of the detector shall be as follows.
 - 1) The long term drift of the zero output shall not exceed $\pm 10\%$ of the operating range in any 8 h period.
 - 2) The short term variation in the zero output shall not exceed $\pm 5\%$ of the operating range over a period of 1 min.

5.4.2 An audible alarm shall be fitted that will recognize all indications above a pre-set level.

5.4.3 All signal thresholds shall be capable of being switched out of the circuit.

5.4.4 Alarm(s) shall be of an audible nature so as not to unduly distract the driver.

5.4.5 Consideration may be given to recording signal outputs from the detector/alarm.

5.5 Electrical power supply equipment

The vehicle shall have an on-board electricity power supply capable of supplying the electrical power requirements for all the systems associated with the detection process, including any ancillaries fitted with the vehicle engine operating at idling speed.

5.6 Display equipment

5.6.1 The following displays shall be provided as a minimum:

- a) electrical power – power on/off;
- b) pump on/off (if fitted);
- c) amber hazard rotating lamp on/off (when permanently fitted only);
- d) audible alarm.

5.6.2 All items on the display shall be clearly visible to the operator responsible for monitoring and adjusting the equipment and be positioned in such a way as to prevent inadvertent operation.

6 Overall performance of the complete equipment

6.1 The OSD shall be 20 ± 10 and shall be repeatable to within 10 % of the mean value.

6.2 The delay time shall not exceed 7 s and shall be repeatable to within 0.5 s across the inlet points. At 30 km/h, this delay corresponds to 58 m of travel.

7 Environmental conditions

The equipment shall perform within the limits specified in this standard for the following range of environmental conditions:

- a) temperature: $-10\text{ }^{\circ}\text{C}$ to $40\text{ }^{\circ}\text{C}$;
- b) pressure: 925 mbar to 1 050 mbar absolute;
- c) relative humidity: 5 % to 100 %.

8 Safety

8.1 All electrical equipment shall be protected by suitable devices.

8.2 The equipment shall not be mounted in a manner likely to cause injury to the operator in normal use. Any edges and projections likely to cause injury in the event of collision shall be suitably padded.

8.3 Consideration shall be given in the design and installation of equipment for possible one person operation. Such a system would need to be automatic to avoid distracting the driver.

9 Installation of pipe work

9.1 All pipework shall be supported and positioned away from sources of high temperature.

9.2 All pipework and fittings shall be accessible and leak tight apart from inlet and outlet points.

10 Maintenance

10.1 The equipment shall be capable of operating satisfactorily for 6 months without requiring attention other than:

- a) changing/charging batteries;
- b) replacing gas cylinders as necessary;
- c) replacing filters;
- d) cleaning dust/water retention devices;
- e) regular and thorough visual inspection of the sampling system for damage.

During this time its performance shall remain within the limits of this standard.

10.2 All equipment, apparatus and circuitry shall be accessible for maintenance.

11 Marking

Products conforming to GIS/E22 shall be permanently marked with the following information:

- a) the number and date of this standard, i.e. GIS/E22:2013 ¹⁾;
- b) the name or trademark of the manufacturer or their appointed agent;
- c) the manufacturer's contact details;
- d) where authorized, the product conformity mark of a third party certification body, e.g. BSI Kitemark.

NOTE Attention is drawn to the advantages of using third party certification of conformance to a standard.

¹⁾ Marking GIS/E22:2013 on or in relation to a product represents a manufacturer's declaration of conformity, i.e. a claim by or on behalf of the manufacturer that the product meets the requirements of the standard. The accuracy of the claim is therefore solely the responsibility of the person making the claim. Such a declaration is not to be confused with third party certification of conformity, which may also be desirable.

Annex A (normative)**Test procedures (for continuous pumped flame ionization measurement system)****A.1 Introduction**

A.1.1 The tests and maintenance work on the equipment mounted on a vehicle for the purpose of performing a survey shall be carried out in accordance with this standard.

A.1.2 The tests are intended to measure and adjust the equipment performance.

A.1.3 The tests shall be performed by competent personnel who understand the use and operation of the equipment.

A.1.4 Initially the detector shall be calibrated using gases appropriate to its operating range. The complete equipment shall then be tested dynamically to ensure conformity to the overall performance as specified in Clause 6.

A.1.5 The alarm level shall be set at the required value. The alarm level shall be clearly displayed on the equipment and/or in the vehicle.

A.1.6 A permanent record of the test results shall be kept.

A.2 Frequency of testing

The survey equipment shall be tested at the following times:

- a) prior to the commencement of a survey (see **A.6.1**);
- b) when the vehicle has been in regular use; intervals between tests shall not exceed 6 months;
- c) when the performance of the equipment is in doubt;
- d) when components are changed.

A.3 Maintenance prior to testing

All items of equipment shall be serviced and tested functionally in accordance with this Standard or as recommended by the manufacturer. The following features shall be included:

- a) pump and ancillaries;
- b) detectors and alarms;
- c) displays, meters and gauges;
- d) all controls (switches, regulators and valves);
- e) sampling system;
- f) electrical power supplies;
- g) electrical wiring;
- h) filters.

A.4 Sampling

Sampling shall be carried out dynamically so as to simulate a vehicle traversing a gas cloud in 0.5 s where one quarter of the sample inlet points within the gas cloud receive the gas and those outside the cloud receive air. The samples combine within the system to give a transient mixture at the detector.

During the testing, the test gas concentration shall equate to:

$$\text{Sensitivity level} \times \frac{N}{4}$$

where:

sensitivity level is the required minimum gas cloud level (but not greater than 500 ppm) as established by */PM/LC/18;

N is the number of inlet points.

A.5 Testing

The survey equipment shall be tested in a gas free atmosphere as follows.

- a) Calibrate the gas detector.
- b) Switch on the equipment.
- c) Install the detector. Check there is not significant change in detector sample flow and adjust the sample treatment system where necessary.
- d) Allow the equipment to reach the correct operating conditions.
- e) Zero the detector and switch all signal thresholds and alarms out of circuit.
- f) Record the total flow rate and number of sample inlet points.
- g) Fill a gas-tight syringe with a volume q of the required concentration of gas in air. The required volume q is derived from the following equation:

$$q = \frac{Q}{N} \times 0.5 \text{ ml}$$

where:

Q is the total flow rate in millilitres per second (ml/s);

N is the number of inlet points.

- h) Inject the gas sample into each inlet point as follows.
 - 1) For separate sample lines, connect the syringe to a 1m length of pipe and one inlet point via a T-piece and inject the sample gas as rapidly as possible.
 - 2) For tubular manifold inlet points, fit the syringe with a large bore hypodermic needle and inject the sample gas well into the manifold as rapidly as possible.
- i) Note the peak ppm reading at the detector, or the maximum millivolt output from the detector using a multimeter for each injection and convert the millivolt reading to ppm.
- j) Repeat steps h) and i) for each inlet point, allowing the detector to zero after each injection, and using a fresh gas sample for each inlet point.
- k) Deviation across the inlet points shall be not more than $\pm 10\%$ of the mean peak value of those recorded in i).
- l) Determine the OSD based on the highest and lowest peak reading at the detector using the following equation:

$$\text{OSD} = \frac{4 \times C_i}{N \times C_r}$$

where:

C_i is the gas concentration injected into the inlet points;

C_r is the peak reading at the detector.

- m) Inject a further gas sample into the inlet point which produced the lowest reading at the detector (C_r) to determine the delay time. The delay time shall not exceed 7 s.
- n) Set the alarm to a level to correspond with the lowest reading at the detector (C_r).
- o) Set the negative drift alarm (where fitted) in accordance with Clause **B.4**.
- p) Inject a further gas sample into the inlet point which produced the lowest reading at the detector (C_r) to ensure the alarm is activated.
- q) Reset the detector to zero.

A.6 Operator checks

A.6.1 Prior to commencement of survey

The equipment shall be tested prior to the commencement of each survey by applying a sample of 500 ppm methane gas (e.g. via an aerosol containing a standard 500 ppm methane in air mixture) for less than 1 s into each of the sample inlet points in turn, and observing that the readings on the gas detector approximate to the stated alarm level.

A.6.2 Replacement of detector

A survey vehicle shall be tested, and the alarm levels set, using the gas detector designated for use with the vehicle. However, it is recognized that, for operational reasons, a detector may need to be changed during survey periods, for this reason the following procedures shall be adopted to ensure compliance with this standard.

- a) Install the replacement detector.
- b) Allow the equipment to reach the correct operating conditions.
- c) Adjust the detector zero to the pre-set alarm level as displayed in the vehicle (it may be necessary to increase the pump speed in addition to the detector zero to achieve this).
- d) Ensure the audible alarm responds when the detector zero is adjusted to the pre-set alarm level. Should the alarm fail to activate, or activate before the pre-set alarm level displayed in the vehicle, the survey system shall be tested in accordance with Clause **A.5**.
- e) Reset the detector zero (and pump speed if necessary).

Annex B (informative)

Recommendations for using carbon absorbers

B.1 General

Carbon absorbers are more efficient than catalytic oxidizers for removing non-methane hydrocarbons. On occasions, their use will cause unpredictable positive drift from zero on the detector.

Once compensation for positive drift has been made manually, there will be a gradual return to normal which will result in negative drift occurring. The operator will not be aware of negative drift, hence a zero alarm should be fitted to the detector.

B.2 Construction and fitting of carbon absorber tube

The construction of the carbon absorber should be designed for ease of connection and disconnection to the existing system. The material should not affect the samples. Copper, brass and nylon are suitable materials.

Appropriate dimensions are 100 mm to 150 mm in length and 15 mm to 22 mm in diameter.

The carbon absorber tube should contain one gram of carbon/charcoal cloth (see Figure B.1) and not powder or granules. More than 1 g will cause greater drift and less will reduce efficiency in removing non-methane hydrocarbons. Prior to its use, carbon cloth should be stored in sealed containers.

A 1 g weight of carbon cloth is equivalent to 5 to 7 pieces of 30 mm² and these should be packed individually, loosely and uniformly along the length of the carbon absorber tube following the normal line of flow. It is recommended that a spare carbon absorber tube is carried in the vehicle in a sealed container.

The carbon absorber should be situated downstream of any calibration supply/point. The flow rate of the sample through the carbon absorber should be 5 l/min \pm 1 l/min.

For survey systems employing microbore sample tubing, with correspondingly low sample flow rates, the above construction should be scaled accordingly.

In line with normal maintenance, the carbon absorber tube should be replaced or refilled at 6 monthly intervals as a minimum, or more frequently if performance deteriorates.

B.3 Drift alarm

The carbon absorber should be used in conjunction with a drift alarm. A typical drift alarm unit is shown in Figure B.2 and described below.

- a) Voltages required to power the drift alarm circuit (i.e. +5 V, 0 V and -5 V) are obtained from the detector's main circuit board (see Figure B.2) via decoupling combinations R6, C2, R7 and C3.
- b) IC1 compares the detector's signal output (from SIG2) with a pre-set negative potential, determined by RV1 in conjunction with R2, R3 and R8. When the detector's output falls below this pre-set (alarm) level, the output of IC1 activates the buzzer via R5 and TR1.
- c) Any high frequencies which may be present in the detector's signal are filtered out by the combination of R1 and C1. Diodes D1 and D2 protect IC1 from being over loaded and D3 prevents TR1 being reversed biased. Positive feedback provided by R4 ensures decisive triggering of the negative zero drift alarm.

B.4 Negative zero drift alarm level

The setting of negative zero drift alarms should take into consideration individual vehicle system dilutions (OSD) to ensure conformity to $^*/PM/LC/18$.

It should be noted that under drift conditions, the gas cloud concentration required to activate the alarm will be increased by an amount equal to the zero drift alarm multiplied by the OSD, e.g. for a pre-set alarm level of 25 ppm and a zero drift alarm of -1 (minus 1), the effective alarm level is 26 ppm which is equal to a gas cloud of 520 ppm (for an OSD of 20).

B.5 Operation

When the negative zero drift alarm is triggered, manual adjustment is required to reset zero. Adjustment for positive drift is as normal. If continuous drift occurs, the carbon absorber should be changed.

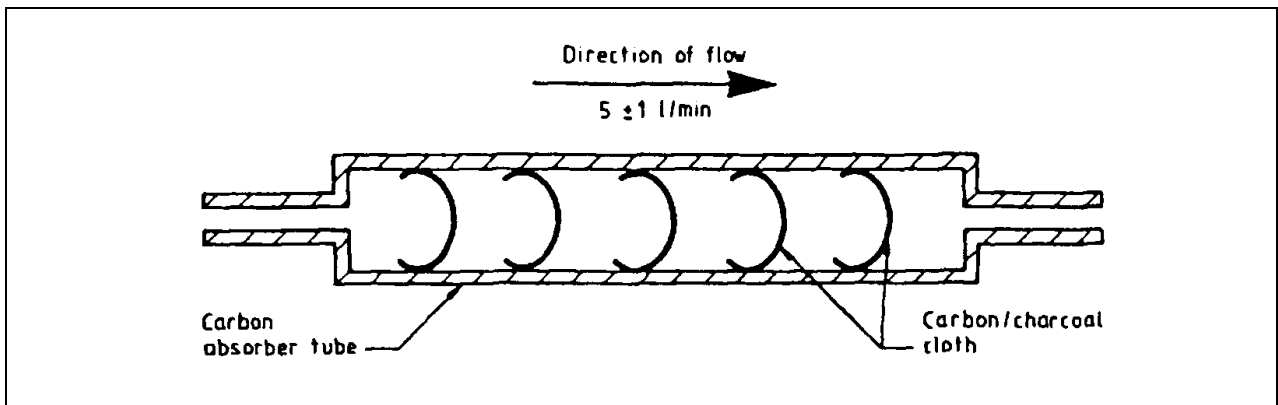

Figure B.1 — Schematic of carbon absorber

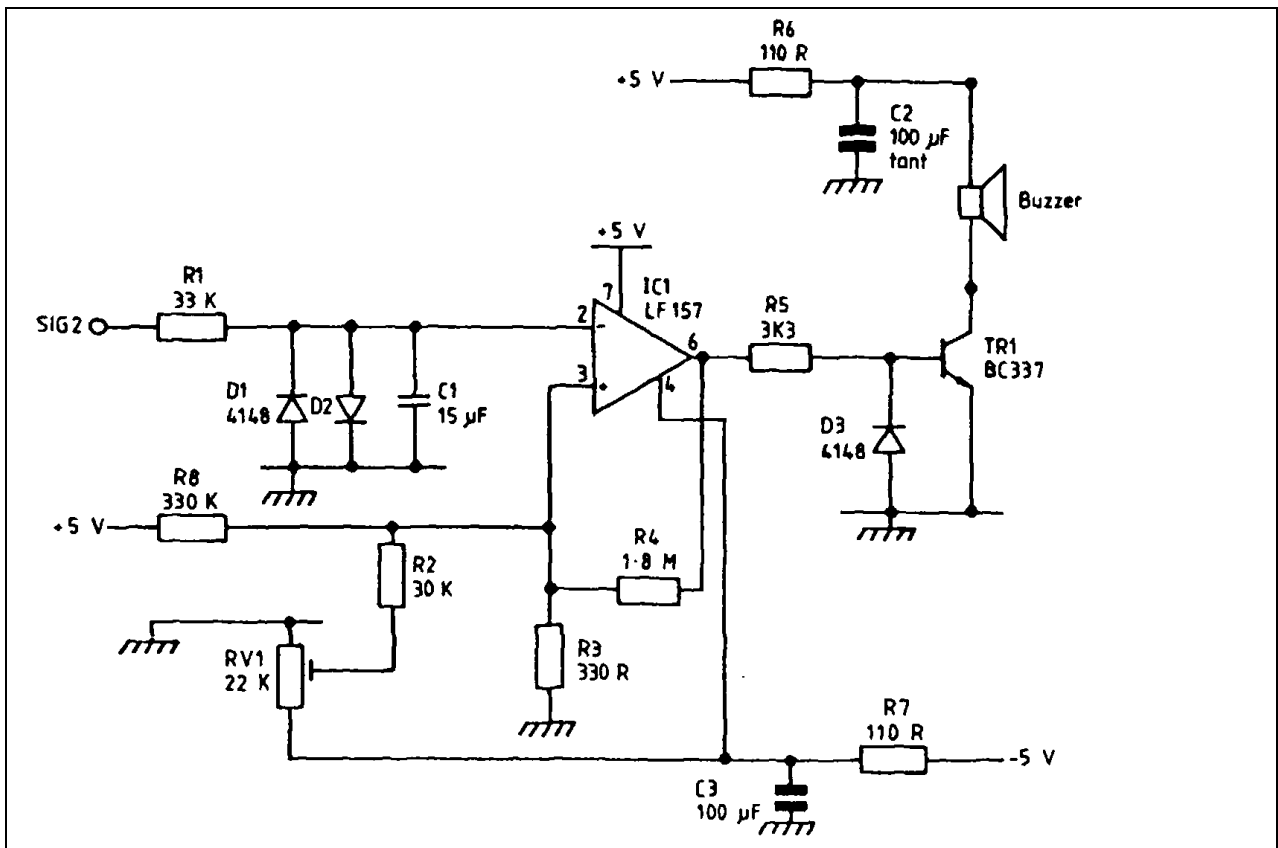

Figure B.2 — Circuit diagram – typical drift alarm unit