

Gas Industry Standard

GIS/PL3: 2023

Specification for

**Self Anchoring mechanical fittings for natural gas and
suitable manufactured gas**



Contents	
Foreword	ii
Mandatory and non-mandatory requirements	ii
Disclaimer	ii
Brief history	iii
1. Scope	4
2. Normative references	4
3. Terms and Definitions	5
4. Symbols and abbreviated terms	7
5. Conformance	8
6. Materials	8
7. Design and construction	9
8. Test pieces	14
9. Test requirements	14
10. Type testing	18
11. Batch release testing	23
12. Approval re-validation	24
13. Marking	24
14. Assembly instructions	25
15. Packaging	25
Annex - A (normative) Leaktightness test method	26
Annex - B (normative) Leaktightness with bending and temperature cycling (16 mm to 63 mm)	27
Annex - C (normative) Leaktightness with temperature cycling (75 mm to 630 mm)	28
Annex - D (normative) Leaktightness after tensile testing at 23 °C	29
Annex - E (normative) Leaktightness after constant load at 80 °C and tensile testing at 23 °C	31
Annex - F (normative) Hydrostatic strength at 80 °C	33
Annex - G (normative) Moisture resistance (plastics-bodied, push-fit)	34
Annex - H (normative) Impact strength (plastics-bodied couplers and elbows)	35
Annex - I (normative) Fire resistance	37
Annex - J (normative) Sturdiness of female internal threads (16 mm to 63 mm)	38
Annex - K (normative) Machining to create maximum or minimum pipe wall compression	39
Annex - L (normative) Long-term pressure test – assembly of fittings that form a gas seal on the external surface of polyethylene pipe	41
Annex - M (normative) GRP service riser covers for polyethylene pipes	42
Annex - N (normative) Long Term Resistance to Corrosion Test	43
Annex - O (normative) Materials, design, performance and testing requirements for temporary, re-usable plastic-bodied fittings Class T	44

Foreword

Gas Industry Standards (GIS) are revised, when necessary, by the issue of new editions. Users should ensure that they are in possession of the latest edition. Contractors and other users external to Gas Transporters should direct their requests for copies of a GIS to the department or group responsible for the initial issue of their contract documentation.

Comments and queries regarding the technical content of this document should be directed in the first instance to the contract department of the Gas Transporter responsible for the initial issue of their contract documentation.

This standard calls for the use of procedures that may be injurious to health if adequate precautions are not taken. It refers only to technical suitability and does not absolve the user from legal obligations relating to health and safety at any stage.

Compliance with this engineering document does not confer immunity from prosecution for breach of statutory or other legal obligations.

Mandatory and non-mandatory requirements

For the purposes of a GIS the following auxiliary verbs have the meanings indicated:

can indicates a physical possibility;

may indicates an option that is not mandatory;

shall indicates a GIS requirement;

should indicates best practice and is the preferred option. If an alternative method is used then a suitable and sufficient risk assessment needs to be completed to show that the alternative method delivers the same, or better, level of protection.

Disclaimer

This engineering document is provided for use by Gas Transporters and such of their contractors as are obliged by the terms of their contracts to comply with this engineering document. Where this engineering document is used by any other party, it is the responsibility of that party to ensure that the engineering document is correctly applied.

Brief history

<p>Edited by BSI in accordance with BS 0-3:1997 Reviewed on behalf of the Gas Distribution Networks' Technical Standard Forum by BSI Corrosion resistance requirements clarified</p>	<p>August 2006 September 2013 March 2014</p>
<p>Annex O added and document reviewed, updated and re-published as a Gas Industry Standard</p>	<p>March 2022</p>
<p>Resistance to fire testing requirements updated in 7.2.3 and I.4</p>	<p>September 2023</p>

© **ENA**, on behalf of Cadent Gas Limited, Gas Networks Ireland, Independent Networks Association, Northern Gas Networks, SGN, and Wales & West Utilities.

This Gas Industry Standard is copyright and must not be reproduced in whole or in part by any means without the approval in writing of either Cadent Gas Limited, Gas Networks Ireland, Independent Networks Association, Northern Gas Networks, SGN, or Wales & West Utilities.

1. Scope

This Gas Industry Standard specifies the requirements for materials, design, performance and testing of mechanical fittings in the nominal size range 16 mm to 800 mm inclusive intended for use with polyethylene (PE) pipe conforming to GIS/PL2-2 or GIS/PL2-8 of the same nominal size and at operating temperatures from $-20\text{ }^{\circ}\text{C}$ to $+40\text{ }^{\circ}\text{C}$.

This Gas Industry Standard specifies requirements to ensure the mechanical fittings are capable of assembly over the temperature range $-5\text{ }^{\circ}\text{C}$ to $+30\text{ }^{\circ}\text{C}$.

This Gas Industry Standard applies primarily to metal-bodied compression, crimped or flared fittings. Requirements are also included for plastics-bodied push-fit and compression fittings (16 mm to 63 mm), which are used primarily to repair damaged polyethylene pipe. It also includes plastics-bodied tapping tees mechanically attached to the polyethylene main. Fittings with a polyethylene flange are considered to be a mechanical connection and are therefore covered by this Gas Industry Standard.

Fittings are classified as:

- class A (limited for use with pipe up to 40 mm for operating pressures not greater than 75 mbar, e.g. thin wall flexible pipe for service insertion);
- class B (suitable for use at operating pressures not greater than 5.5 bar);
- class C (suitable for use at operating pressures not greater than 7 bar).
- class T (Temporary, re-useable plastic-bodied mechanical fittings).

NOTE The permissible pipe operating pressures are dependent on diameter, SDR and operating temperature.

The Gas Industry Standard is designed to ensure that the mechanical joints will give leak-free performance over the minimum design life of 50 years and that the polyethylene pipe will stretch rather than pull out of the mechanical joint when the polyethylene pipe is subjected to tensile forces or internal pressure

2. Normative references

The following referenced documents are indispensable for the application of this document. For dated references, only the edition cited applies. For undated references, the latest edition of the referenced document (including any amendments) applies.

2.1 British and European standards

BS 5252, *Framework for colour co-ordination for building purposes.*

BS EN 682, *Elastomeric seals — Materials requirements for seals used in pipes and fittings carrying gas and hydrocarbon fluids.*

BS EN 837-1, *Pressure gauges — Bourdon tube pressure gauges — Part 1: Dimensions, metrology, requirements and testing.*

BS EN 921, *Plastics piping systems. Thermoplastics pipes. Determination of resistance to internal pressure at constant temperature.*

BS EN 1562, *Founding — Malleable cast irons.*

BS EN 1563, *Founding — Spheroidal graphite cast iron.*

BS EN 1775, *Gas supply — Gas pipework for buildings — Maximum operating pressure less than or equal to 5 bar — Functional recommendations.*

BS EN 1982, *Copper and copper alloys — Ingots and castings.*

BS EN ISO 3501, *Plastics piping systems. Mechanical joints between fittings and pressure pipes. Test method for resistance to pull-out under constant longitudinal force*

BS EN 12117, *Plastics piping systems — Fittings, valves and ancillaries — Determination of gaseous flow rate/pressure drop relationships.*

BS EN ISO 9080, *Plastics piping and ducting systems — Determination of the long-term hydrostatic strength of thermoplastics materials in pipe form by extrapolation.*

BS EN ISO 13686, *Natural gas — Quality designation.*

BS EN ISO/IEC 17025, *General requirements for the competence of testing and calibration laboratories.*

BS EN ISO 17778, *Plastic piping systems. Fittings, valves and ancillaries. Determination of gaseous flow rate/pressure drop relationships.*

ISO 7-1, *Pipe threads where pressure-tight joints are made on the threads — Part 1: Dimensions, tolerances and designation.*

ISO 7-2, *Pipe threads where pressure-tight joints are made on the threads — Part 2: Verification by means of limit gauges.*

ISO 3458, *Plastic Piping Systems – Mechanical joints between fittings and pressure pipes — Test method for leaktightness under internal pressure.*

ISO 3503, *Plastic Piping Systems – Mechanical joints between fittings and pressure pipes — Test for leaktightness under internal pressure when subjected to bending.*

ISO 4065, *Thermoplastics pipes — Universal wall thickness table.*

ISO 7005-1, *Pipe flanges — Part 1: Steel flanges for industrial and general service piping systems.*

ISO 7005-2, *Metallic flanges — Part 2: Cast iron flanges.*

ISO 12162, *Thermoplastics materials for pipes and fittings for pressure applications — Classification and designation and design coefficient.*

2.2 American Society for Testing and Materials

ASTM B117, *Standard Practice for Operating Salt Spray (Fog) Apparatus*

2.3 Gas Industry Standards

GIS/F2, *Specification for steel welding pipe fittings 15mm to 450mm inclusive nominal size for operating pressures not greater than 7 bar.*

GIS/LC8-4, *Specification for methods of repairing leaking ferrous gas mains — Part 4: Pipe repair clamps, split collars and under pressure branch connections.*

GIS/PL2-1, *Specification for polyethylene pipes and fittings for natural gas and suitable manufactured gas — Part 1: General and polyethylene compounds for use in polyethylene pipes and fittings.*

GIS/PL2-2, *Specification for polyethylene pipes and fittings for natural gas and suitable manufactured gas — Part 2: Pipes for use at pressures up to 5.5 bar.*

GIS/PL2-4, *Specification for polyethylene pipes and fittings for natural gas and suitable manufactured gas — Part 4: Fusion fittings with integral heating element(s).*

GIS/PL2-6, *Specification for polyethylene pipes and fittings for natural gas and suitable manufactured gas — Part 6: Spigot end fittings for electrofusion and/or butt fusion purposes.*

GIS/PL2-8, *Specification for polyethylene pipes and fittings for natural gas and suitable manufactured gas — Part 8: Pipes for use at pressures up to 7 bar.*

3. Terms and Definitions

For the purposes of this document, the following definitions apply.

3.1 Contractor

The person, firm or company with whom a Gas Transporter enters into a contract to which this Standard applies, including the Contractor's personal representatives, successors and permitted

assigns.

3.2 Batch acceptance

sample testing of a specified quantity of fittings of a given type/size for delivery to the gas transporter, or some other agreed definition for fittings delivered by the contractor in bulk

3.3 maximum operating pressure (MOP)

maximum pressure at which a system can be operated continuously under normal conditions

3.4 Strength test pressure

The pressure applied to a system during a strength test.

3.5 mechanical fitting

fitting for assembling polyethylene pipe to another polyethylene pipe or any other element of the piping system. The fitting generally includes a compression part to provide pressure integrity, leaktightness and resistance to end loads. A pipe internal supporting liner providing a permanent support for a polyethylene pipe to prevent creep in the pipe wall under radial compressive forces is applicable

NOTE 1 The metallic parts of the fitting can be assembled to metallic pipes by screw-threads, compression joints, welded or flanged connections.

NOTE 2 In some cases, the supporting sleeve at the same time constitutes a grip ring.

NOTE 3 The mechanical fitting can be supplied for field assembly or pre-assembled by the manufacturer.

3.6 Temporary fitting

A re-usable mechanical fitting that is not backfilled, the fitting connection integrity is checked daily and the maximum time in continuous service is 168 hours (1 week).(see Annex O).

3.7 full-end-load resistance

combination of component and joint design and properties such that under any load condition the pipe will fail first

3.8 stiffener insert/internal supporting liner

rigid internal tubular stiffener that provides permanent support for the polyethylene pipe to prevent creep in the pipe wall under radial compressive forces

3.9 grip ring

ring that holds the polyethylene pipes in place and prevents pull-out from the fitting

NOTE In some cases, the stiffener also constitutes a grip ring.

3.10 glass reinforced plastic (GRP) protective service riser cover

straight GRP pultruded tube to protect the polyethylene service pipe from sunlight and damage (see Annex M)

3.11 batch of fittings

specified and marked quantity of fittings of a given type and dimensions

3.12 type test

test performed to prove that the material, a component or an assembly, after it has been designed or the design modified, conforms to the requirements given in a standard

3.13 minimum bore

smallest internal diameter, d_i , measured at any cross-section of the fitting assembly

3.14 fitting assembly

complete joint assembly, consisting of a polyethylene pipe jointed, by means of a mechanical pipe-jointing system, to another polyethylene pipe or to a metal pipe or fitting

3.15 virgin material

thermoplastic material in the form of granules or powder that has not been previously processed other than for compounding and to which no reprocessible or recyclable materials have been added

3.16 reprocessible (rework) material

material, prepared from clean unused rejected pipes, fittings or valves, produced in a manufacturer's plant by a process such as injection-moulding or extrusion, which will be reprocessed in the same plant

NOTE Such material may include trimmings from the production of such pipes, fittings and valves.

3.17 accuracy class (pressure gauge)

maximum permissible error of the gauge, expressed as a percentage of the measurement range

3.18 gaseous fuel

any fuel that is in gaseous state at a temperature of 15 °C, at atmospheric pressure

3.19 standard dimension ratio (SDR)

numerical designation of a pipe series, which is a convenient round number, approximately equal to the dimension ratio of the nominal outside diameter, d_n , and the nominal wall thickness, e_n

SDR = Standard dimension ratio = $\frac{\text{Nominal outside diameter}}{\text{Nominal wall thickness}}$

3.20 plastics-bodied fitting

fitting with a plastics body that is designed to form a push-fit or compression joint to polyethylene pipes in sizes 16 mm to 63 mm

NOTE Polyethylene flanged fitting are not considered to be plastics-bodied fittings.

4. Symbols and abbreviated terms

d_i	minimum inside diameter of a fitting assembly
d_n	nominal outside diameter of the polyethylene pipe
e_n	nominal wall thickness of the polyethylene pipe
MOP	maximum operating pressure
MRS	minimum required strength (see ISO 12162)
SDR	standard dimension ratio (see ISO 4065)
T_{\max}	maximum temperature to which a fitting may be exposed during normal operation (+40 °C)
T_{\min}	minimum temperature to which a fitting may be exposed during normal operation (−20 °C).

5. Conformance

5.1 Units of measurement

In this standard, for data expressed in both SI and USC units, a dot (on the line) is used as the decimal separator, and no comma or space is used as the thousands separator, in order to be consistent with other Gas Transporter specifications.

6. Materials

6.1 General

Any part of the fitting may be made of plastic, elastomer or metal. The fitting shall be suitable to carry gaseous fuels and in particular natural gas having a composition to BS EN ISO 13686 or suitable manufactured gas.

All components shall conform to the relevant British Standard(s) or international standard(s). In all cases, fitness for purpose of the components shall be demonstrated.

The materials and the constituent elements used in making the fitting (including rubber, greases and any metal parts as may be used) shall be as resistant to the external and internal environments as the other elements of the piping system. They shall also have a life expectancy under the following conditions at least equal to that of the polyethylene pipes conforming to GIS/PL2-2 or GIS/PL2-8 with which they are intended to be used:

- a) during storage;
- b) under the effect of the internal gas;
- c) with respect to the service environment and operating conditions.

Fittings material in contact with the polyethylene pipe shall not adversely affect pipe performance or initiate stress cracking.

6.2 Metal components

Materials used in the fitting shall conform to the following requirements:

- a) copper alloy components shall conform to BS EN 1982 grades CC491K (CuSn5Zn5Pb5-C) and CC492K (CuSn7Zn2Pb3-C).
- b) components in malleable iron shall conform to BS EN 1562, grade EN-GJMB-300-6 or EN-GJMW-350-4;
- c) components in ductile iron shall conform to BS EN 1563;
- d) components made from other materials shall conform to a specification. Fitness for purpose shall be demonstrated.

All metal parts, including brackets and fixings, shall be suitably protected against corrosion and deterioration during storage, installation and operation.

When dissimilar metallic materials are used that can be in contact with moisture, steps shall be taken to avoid the possibility of galvanic corrosion.

In the first instance, fittings should be made from materials that have an inherent resistance against corrosion.

For above ground fittings, the fitting shall be protected by applying a coating in accordance with an appropriate specification or standard to give corrosion protection during the anticipated 50 year life of the fitting.

For below ground fittings, the fitting shall be protected by applying an appropriate coating to give a 50 year life in a corrosive environment.

NOTE Protective coating is in addition to any wrapping that may take place at the time of installation

6.3 Plastic components

All load-bearing plastic components shall be made from thermoplastics or reinforced thermoplastics. Determination of a long-term hydrostatic strength is critical in the selection of plastics materials and is a first step in designing plastics fittings that will last the lifetime of the polyethylene piping that they connect.

Plastics materials for components intended to be pressure-containing and subject to continuous stress, either in hoop or tension, shall have an ISO material classification. The classification of the thermoplastics materials shall be determined in accordance with ISO 12162; the extrapolation method for the long-term strength is given in BS EN ISO 9080. The classification of other plastics materials shall be obtained with the same extrapolation method, except that failure data may be obtained from tensile bars, plane-strain specimens and actual fitting specimens.

Before using plastics-bodied fittings or components for the transport of gaseous fuels, which have constituents other than those in the natural gas specified in BS EN ISO 13686, the potential effects of all the constituents of the gas shall be taken into account since, at a certain level of concentration, these other constituents could impair the properties of fittings or components.

Materials shall have a demonstrated resistance to environmental stress cracking when exposed, under stress, to chemical compounds encountered in, or external to, gas piping systems, and a demonstrated resistance to bacteriological decomposition. Such compounds include, but are not limited to, ice-thawing chemicals, fertilizers, insecticides, herbicides, leak-detection fluids, acids, bases and antifreeze solutions used to thaw frozen lines. Liquids such as antifreeze agents, odorants and hydrocarbons are known to have deleterious effects on some plastics, particularly under service conditions.

Pressure-bearing components shall be produced from virgin materials, reprocessible material or a combination of virgin and reprocessible material. Only clean reprocessible material generated from the manufacturer's own production of fittings to this specification may be used, and it shall be derived from the same resin as used for the relevant production.

Polyethylene components shall be made from compound conforming to GIS/PL2-1.

6.4 Elastomers

Materials for elastomeric seals shall conform to BS EN 682 Type G.

6.5 Other materials

Greases or lubricants shall not exude onto the polyethylene pipes where they could interfere with fusion, and they shall not affect the long-term performance of fitting materials.

Other materials conforming to 6.1 may be used, provided that it is proven that the fittings conform to this specification.

7. Design and construction

7.1 General

Class A fittings shall be suitable for use with special thin-wall polyethylene service insertion pipes, which are normally corrugated. The maximum operating pressure (MOP) is 75 mbar.

Class B fittings shall be suitable for use with pipe of SDR 11, SDR 17.6, SDR 21 or SDR 26 having the same nominal diameter and conforming to GIS/PL2-2. The maximum operating pressure (MOP) is 5.5 bar.

Class C fittings shall be suitable for use with pipe of SDR 11 having the same nominal diameter and conforming to GIS/PL2-8. The maximum operating pressure (MOP) is 7 bar.

NOTE 1 For pipe sizes 16 mm and 20 mm, the actual values are SDR 7 and SDR 9 respectively due to minimum wall thickness considerations.

GIS/PL3:2023

Class T fittings (Temporary, re-useable plastic-bodied mechanical fittings) shall be designed in accordance with Annex O. Class T fittings shall be suitable for use with pipe of SDR11, SDR13.6, SDR17.6, SDR21 or SDR26 having the same nominal diameter and conforming to GIS/PL2-2.

Fittings shall be capable of field assembly at temperatures in the range -5 °C to +30 °C inclusive. If mechanical aids are necessary, these shall be supplied by the manufacturer or contractor.

NOTE 2 Fittings that are always factory assembled need not conform to these field assembly requirements.

NOTE 3 The fitting should have sufficiently large bearing surfaces to avoid deformation during assembly. The fitting and tools should be designed to avoid any weakening which influences the performance of the joint assembly.

Assembly of the fitting shall not induce twisting of the polyethylene pipe or corrugated polyethylene pipe.

Polyethylene pipe shall not be machined, for example to produce threads or grooves.

Where the design of the fittings relies on radial compressive forces on the pipe for sealing, an insert stiffener (internal pipe support liner) shall be supplied so that it provides support over the entire compression area. A split tube is not permitted. Except for preassembled fittings, the insert stiffener shall have a means to control its position in the pipe. The design of the insert stiffener shall eliminate the possibility of gouging the polyethylene pipe bore either during assembly or when in service.

The manufacturer shall supply full written assembly instructions.

Fittings components shall not show any signs of surface damage or inclusions that would prevent conformity to this specification.

7.2 Metal-bodied fittings for pipe sizes up to and including 63 mm

7.2.1 Anti-shear sleeves (transition fittings – 16 mm to 55 mm)

The design of a fitting shall be such that it can securely anchor (push-fit assembly) a polyethylene anti-shear sleeve as given in Table 1. The fitting and anti-shear sleeve shall be capable of assembly at temperatures down to -5 °C, and the anti-shear sleeve shall maintain an interference fit with the fitting at temperatures up to 40 °C. Anti-shear sleeves are only required for transition fittings sizes in the range 16 mm to 55 mm.

Table 1 — Requirements for polyethylene anti-shear sleeves

Service pipe nominal size	16	20	25	32	50	55
Anti-shear sleeve pipe size	32 ^{a)} or 50 ^{b)}	32 ^{a)} or 50 ^{b)}	50 ^{b)}	50 ^{b)}	75 ^{b)}	75 ^{b)}

NOTE All dimensions are in millimetres.

- a) Sleeve pipe size 32 mm, SDR 11 produced in accordance with GIS/PL2-2.
- b) Sleeve pipe size 50 mm and 75 mm, SDR 17.6 produced in accordance with GIS/PL2-2.
- c) All anti-shear sleeves shall have a length of not less than 250 mm.

7.2.2 Straight transition fittings

Straight transition fittings are class B or class C fittings used for joining polyethylene pipe to steel pipe, or class A fittings for joining to flexible plastic service insertion pipe.

Class A straight transition fittings shall provide an end load-bearing connection to the steel service pipe through which the corrugated pipe is inserted. The assembly shall be capable of being tightened to the required torque without applying a rotational moment to the corrugated plastic insertion pipe.

Straight transition fittings shall include provision for anti-shear protection on the polyethylene side, except for pipe nominal size 63 mm.

Straight transition fittings (Types A, B and C) shall be capable of meeting the requirements of the

pull-out test (see 9.6) when assembled with polyethylene pipe and steel pipe (both black and galvanized). End load requirements for the steel side shall be as for the pull-out requirements of the polyethylene side.

7.2.3 Above ground, through-wall fittings

Above ground, through-wall fittings are class B transition fittings for joining a vertical polyethylene pipe to a horizontal through-wall steel pipe.

Above ground, through-wall fittings shall have the steel pipe outlet welded or brazed to the fitting body and externally sleeved by a tight-fit polyethylene tube. Steel outlets with a diameter of up to and including 2" shall be threaded in accordance with ISO 7-1. At larger diameters other types of joint (eg welded, flanged) may be permitted.

For nominal sizes up to and including 32 mm, the above ground, through-wall fitting shall include an integral shut-off valve. Access to the shut-off valve shall be via a secure cap or plug. Operation of the shut-off valve shall not adversely affect the corrosion protection of the above ground, through-wall fitting.

Where the outlet of the fitting is designed to terminate inside a building the fitting shall meet the fire resistance requirements of 9.11.

All above ground, through-wall fittings shall have provision on the inlet to the body for holding an approved GRP protective riser cover to the dimensions in Annex M.

7.2.4 Below ground, through-wall fittings

Below ground, through-wall fittings are class B metal-bodied fittings for joining polyethylene pipe to steel pipe, incorporating a steel sleeve with an external tight-fit polyethylene tube extending beyond the steel sleeve.

Below ground, through-wall fittings shall meet the following requirements:

- a) they shall incorporate a watertight seal between the extension of the polyethylene tube and the polyethylene service pipe;
- b) the joint between the fitting and the steel encasing sleeve shall withstand a pull-out force of 5 kN;
- c) they shall meet the fire resistance requirements of 9.11;
- d) they shall have the outlet threaded in accordance with ISO 7-1.

7.2.5 Service head adapters (SHA)

Service head adapters are class B metal-bodied fittings used within a building to join a steel encased polyethylene service to a steel pipe. Service head adapters are also used for class A applications, where the fitting connects to the corrugated polyethylene service pipe inside the old steel service.

The service head adapters shall meet the following requirements:

- a) the joint between the service head adapter and the steel encasing sleeve shall withstand a pull-out force of 5 kN;
- b) they shall meet the fire resistance requirements of 9.11;
- c) they shall have the outlet threaded in accordance with ISO 7-1;
- d) in assembling any part of the service head adapter, according to the contractor's instructions, there shall be no twisting transmitted to the polyethylene service pipe;
- e) two plugs threaded in accordance with ISO 7-1, size $R_{1/4}$, shall be incorporated in the fitting body to enable grout or sealing foam to be injected/vented into the annulus between the polyethylene service pipe and the old steel service pipe. The two threaded plugs shall be in the same radial plane at between 60° and 90° to each other. The design of the service head adapter shall be such that the grout or sealing foam cannot enter the polyethylene service pipe when the polyethylene/metallic joint is correctly made.

7.2.6 Garden fitting

Garden fittings are class A, below-ground, metal-bodied fittings used outside the building to join to the steel riser sleeve and the corrugated polyethylene service inside. The inlet to the fitting forms a mechanical joint to the polyethylene service that protrudes from the steel encasing sleeve service coming from the main.

The garden fittings shall meet the following requirements:

- a) the joint between the garden fitting and the steel encasing sleeve entering the building shall withstand a pull-out force of 5 kN;
- b) in assembling any part of the service head adapter, according to the contractor's instructions, there shall be no twisting transmitted to the polyethylene service pipe;
- c) one plug threaded in accordance with ISO 7-1, size R_{1/4}, shall be incorporated in the fitting body to enable grout or sealing foam to be injected/vented into the annulus between the corrugated polyethylene service pipe and the old steel riser pipe. The design of the garden fitting shall be such that the grout or sealing foam cannot enter the corrugated polyethylene service pipe when the corrugated polyethylene/metallic joint is correctly made.

7.2.7 Service riser fittings

7.2.7.1 Service riser fittings are class B fittings that can be either:

- a) above ground transition fittings for joining a polyethylene riser, encased in an approved protective sleeve, to a steel pipe; or
- b) above ground polyethylene to polyethylene fittings used for the construction of polyethylene risers and polyethylene laterals.

7.2.7.2 The service riser fittings shall meet the following requirements:

- a) where threaded, the threads shall be in accordance with ISO 7-1;
- b) they shall have provision for holding an approved protective riser(s) to the dimensions in Annex M;
- c) in the case of transition service riser fittings, there shall be an elastomeric seal to prevent the ingress of water into the protective sleeve;
- d) plastics and elastomeric components in the service riser assembly shall have adequate resistance to weathering.

7.2.8 Meter box adapters

Meter box adapters are class B transition fittings of nominal size 16 mm, 20 mm, 25 mm and 32 mm.

Meter box adapters shall meet the following requirements:

- a) they shall be suitable for the standard the gas transporter meter boxes;
- b) the body shall have provision for holding the appropriate size of approved protective sleeve;
- c) the installed length shall be when measured from the underside of the meter box floor and shall terminate in a metal thread conforming to ISO 7-1, size R_{3/4};
- d) they shall be mechanically retained to the base of the meter box;
- e) plastics and elastomeric components in the meter box assembly shall have adequate resistance to weathering.

7.2.9 Semi-concealed meter box adapters

Semi-concealed meter box adapters are class B transition fittings of nominal size 16 mm, 20 mm, 25 mm and 32 mm.

Semi-concealed meter box adapters shall meet the following requirements:

- a) they shall be suitable for the standard the gas transporter semi-concealed meter box;
- b) the installed length shall be 52_{-0}^{+4} mm when measured from the underside of the meter box floor and shall terminate in a metal thread conforming to ISO 7-1, size R3/4;
- c) a means shall be provided to retain a polyvinyl chloride (PVC) bend.

7.3 Metal-bodied fittings for pipe sizes 75 mm to 800 mm inclusive

Internal restrictions in the pipe bore shall not hinder the free passage of pigs.

Fittings shall not have threaded end connections.

7.4 Flanged fittings

Class B flanged fittings shall terminate in a polyethylene flange suitable to be joined to a metal flange conforming to ISO 7005-1 or -2 of pressure class PN16 or a polyethylene flange of pressure class PN16.

Class C flanged fittings shall terminate in a metal or polyethylene flange suitable to be joined to a metal flange conforming to ISO 7005-1 or -2 of pressure class PN16 or a polyethylene flange of pressure class PN16.

A specific size of class B fitting which might be terminated with a range of different metallic flange sizes and sections, and which is produced in low volume (less than 10 off per year) may be considered as a special case for approval purposes. In the first instance, the fitting shall be fully tested in accordance with this specification. If a proposed variation of the fitting is produced and the variation is confined only to a change in the flange section itself, or its means of attachment to the fitting, then it is only necessary to confirm that the variant flange, and its method of attachment to the fitting has at least the same amount of strength as the original design. This shall be demonstrated either by testing or calculation. In all cases, a proposed variant fitting shall be proof tested to 1.5 times the maximum operating pressure.

7.5 Fittings with electrofusion sockets

Polyethylene electrofusion sockets shall conform to GIS/PL2-4.

7.6 Fittings with spigot ends

Polyethylene spigot ends shall conform to GIS/PL2-6.

7.7 Plastics-bodied fittings (16 mm to 63 mm)

7.7.1 General

Plastics-bodied fittings are class B fittings that can be either push-fit or compression type fittings to polyethylene pipe. They shall all be coloured black or yellow to the shade 10E55 of BS 5252.

Where the primary gas seal on push-fit fittings is achieved by means of an elastomeric seal, there shall be at least two separate seals. The seals shall not depend on the gas pressure to create the seal, nor shall they allow water ingress if the pipe is depressurized.

Where a gas tight seal is made between on the external surface of a polyethylene pipe, e.g. elastomeric or an "O" ring seal, the long-term pressure test shall be carried out with the fitting assembled with polyethylene test pipes that have four axial grooves in accordance 9.2.

Push fit couplers and elbows shall have a moisture seal between the polyethylene pipe and the plastics body at the mouth of the fitting to minimize the ingress of water and preclude the ingress of dirt into the primary gas seals.

Unless special tools are required, the design of the fitting shall preclude disassembly either in service or due to interference.

The minimum wall thickness of any hoop stress bearing plastics body part shall be such that the performance of the fitting is equivalent to that of the polyethylene pipes with which the fitting is designed to be used.

GIS/PL3:2023

7.7.2 Couplers and elbows

Plastics-bodied couplers and elbows are primarily repair fittings for joining polyethylene pipe to polyethylene pipe and can be either compression type or push-fit type fittings. Push-fit fittings shall be assembled with notched polyethylene pipe when conducting the test programme.

Plastics-bodied couplers and elbows shall be impact resistant in accordance with 9.10.2.

7.7.3 Tapping tees (polyethylene main)

Plastics-bodied tapping tees are fittings which are mechanically attached to the polyethylene main, have a means of cutting through the pressurized main pipe and allowing gas flow into the outlet pipe, and have an outlet which is electrofused or mechanically connected by a push-fit or compression joint to a polyethylene service pipe.

The contractor shall specify the method of attachment of the tapping tee to the main. If bolts are used, this shall include the tightening sequence and the method of determining the correct bolt load.

Plastics-bodied tapping tees shall meet the following requirements.

- a) The outlet joint shall meet all the requirements of 7.7.1 and 7.7.2.
- b) The tapping tee cap shall meet the relevant requirements of GIS/PL2-4
- c) The cutting device shall meet the relevant requirements of GIS/PL2-4 (except that operation with other than a 12 mm AF hexagonal key may be proposed by the contractor for consideration as a variant by the gas transporter).
- d) Provision shall be made for pressure testing of the connected service pipe and the outlet joint without removal of the cutter.
- e) The pressure drop across the tapping tee shall conform to GIS/PL2-4.
- f) The tapping tee shall meet the impact strength requirements of GIS/PL2-4.
- g) The tapping tee mechanical attachment to the polyethylene main shall provide an effective seal for 50 years, without requiring further attention. If bolts are used to connect to the main, the bolt load relaxation test shall be conducted (see 9.10.7).

8. Test pieces

The tests specified shall be carried out on fitting assemblies constructed by the fitting manufacturer or assembled by the user in accordance with manufacturer's written instructions, including lubricants if required in the manufacturer's instructions.

Class A fittings shall be assembled with corrugated pipe.

Class B fittings shall be assembled with polyethylene pipe conforming to GIS/PL2-2.

Class C fittings shall be assembled with polyethylene pipe conforming to GIS/PL2-8.

Class T fittings refer to Annex O.4.1

NOTE See also fitness for purpose requirements (11.4).

NOTE If guidance is required for the conditioning of polyethylene pipe and fittings (plastics and metal), see GIS/PL2-2.

Polyethylene flanges are generally connected to a metallic flange, e.g. a valve, though on occasion polyethylene to polyethylene flange connections are made. Testing shall therefore be conducted with a polyethylene to polyethylene flange assembly. Approval of a polyethylene to polyethylene flange connection automatically covers the requirements for a polyethylene flange to metal flange connection of the same size and type.

Class B or class C fittings that form a gas seal on the external surface of the polyethylene pipe, e.g. elastomeric or an "O" ring seal, shall be assembled with notched polyethylene pipe as indicated in Annex L when conducting the long-term pressure tests.

9. Test requirements

Temporary, re-useable plastic-bodied mechanical fittings shall be tested in accordance with Annex O.

9.1 Short-term hydrostatic pressure test at 20 °C (all sizes)

When tested as specified in BS EN 921, the assembly shall withstand minimum hold pressure given in Table 2 at a temperature of 20 °C ± 2 °C for a period of 1 h without failure or leakage and also shall not fail or leak when raised to the higher pressure for a period of 5 s.

Table 2 — Short-term hydrostatic test pressures and times

Polyethylene pipe	1 h hold pressure			Higher pressure for 5s hold
	bar			
SDR	Class A	Class B	Class C	Bar
11 ^{a)}	-	24	30	32
13.6	-	12	-	16
17.6	-	14	-	19
21	-	12	-	16
26	-	9.6	-	13
Corrugated pipe	4.2	-	-	5.6

^{a)} For pipe sizes 16 mm and 20 mm, the actual values are SDR 7 and SDR 9 respectively due to minimum wall thickness considerations.

9.2 Long-term hydrostatic pressure test at 20 °C (all sizes)

When tested as specified in BS EN 921, the jointed assemblies shall withstand the minimum hydrostatic test pressures and times in Table 3 at 20 °C ± 2 °C.

Class B or class C fittings that form a gas seal on the external surface of the polyethylene pipe, e.g. elastomeric or an “O” ring seal, shall be assembled with notched polyethylene pipe as indicated in Annex L when conducting the long-term pressure tests.

9.3 Leaktightness test (all sizes)

When a fitting assembly, assembled in accordance with Clause 8, is tested in accordance with Annex A, it shall not leak.

The integral valve of above ground, through-wall fittings, if fitted, shall meet the requirements of the clause.

9.4 Leaktightness with bending and temperature cycling (16 mm to 63 mm)

When a fitting assembly, assembled in accordance with Clause 8, is tested in accordance with Annex B, it shall not leak initially or at the end of the test. For class A fittings for joining to flexible, corrugated polyethylene pipe, the bending test shall be omitted but the temperature cycling is still to be conducted.

9.5 Leaktightness with temperature cycling (75 mm to 800 mm)

When a fitting assembly, assembled in accordance with Clause 8, is tested in accordance with Annex C, it shall not leak initially or at the end of the test.

Table 3 — Long-term hydrostatic test pressures and times

Polyethylene pipe SDR	Class A		Class B				Class C	
	All types		Non-plastics-bodied		Plastics-bodied		All types	
	Pressure bar	Time h	Pressure bar	Time h	Pressure bar	Time ^{b)} h	Pressure bar	Time h
11 ^{a)}	—	—	19	1 000	19	5 000	22.5	1 000
13.6	—	—	15	1 000	—	—	—	—
17.6	—	—	11.4	1 000	—	—	—	—
21	—	—	9.5	1 000	—	—	—	—
26	—	—	7.6	1 000	—	—	—	—
Corrugated pipe	3.3	1 000	—	—	—	—	—	—

^{a)} For pipe sizes 16 mm and 20 mm, the actual values are SDR 7 and SDR 9 respectively due to minimum wall thickness considerations.

^{b)} For batch release testing of plastic-bodied fittings the test time shall be 1 000 h.

9.6 Leaktightness after tensile testing at 23 °C (all sizes)

When a fitting assembly, assembled in accordance with Clause 8, is tested in accordance with Annex D, none of the following shall occur:

- damage or permanent deformation of the fitting assembly to an extent that would prevent conformity to this specification;
- pull-out of the pipe;
- leakage during the leaktightness test that is conducted after the tensile test.

9.7 Leaktightness after constant load at 80 °C and tensile testing at 23 °C (all sizes)

When a fitting assembly, assembled in accordance with Clause , is tested in accordance with Annex E, none of the following shall occur:

- damage or permanent deformation of the fitting assembly to an extent that would prevent conformity to this specification;
- pull-out of the pipe;
- leakage during the leaktightness test that is conducted after the tensile test.

9.8 Hydrostatic strength at 80 °C (all sizes)

When assembled in accordance with Clause 8 and tested in accordance with Annex F, the assembly shall not leak.

9.9 Pressure drop

9.9.1 General

The pressure drop across the fitting shall be kept to a minimum.

The minimum internal bore diameter, d_i , shall be stated by the manufacturer

NOTE The pressure drop across service tees is covered in GIS/F2, and the pressure drop across plastics-bodied tapping tees shall conform to GIS/PL2-4.

9.9.2 16 mm to 63 mm

The gaseous flow/pressure drop relationship is determined by measuring the air flow rate (m^3/h) at ambient temperature ($23\text{ °C} \pm 2\text{ °C}$) corresponding to a pressure drop across the fitting of 0.5 mbar and shall be declared by the manufacturer. The test method shall be in accordance with BS EN 12117. Full details of the test results shall be made available in a report.

Only transition and above-ground, through-wall fittings in the size range 16 mm to 63 mm are

required to be tested.

9.9.3 75 mm to 800 mm

The bore diameter shall not be restricted by liners or other components by greater than 15 % of the minimum permitted bore diameter of the corresponding polyethylene pipe.

9.10 Additional test requirements for plastics-bodied fittings (class B)

9.10.1 Moisture resistance for push-fit fittings only

When plastics-bodied, push-fit fittings are tested as specified in Annex G, there shall be no leakage into the fitting.

9.10.2 Impact strength (couplers and elbows)

When plastics-bodied couplers and elbows are tested as specified in Annex H, the fitting shall not leak.

9.10.3 Tapping tee impact strength

A tapping tee, when tested in accordance with GIS/PL2-4, shall withstand an impact energy of 100 J without failure.

9.10.4 Tapping tee cap pneumatic pressure leak test

When the caps of plastics-bodied tapping tees are tested in the pneumatic leak test as specified in GIS/PL2-4, there shall be no leakage from the caps.

9.10.5 Tapping tee cutting torque test

When cutters of plastics-bodied tapping tees are tested as specified in GIS/PL2-4, the operating torques and design requirements shall conform to the stated requirements.

9.10.6 Tapping tee pressure drop

The pressure drop across the tapping tee shall conform to GIS/PL2-4, when measured between the main pipe and the service outlet.

9.10.7 Bolt load relaxation test for tapping tees

When bolt load relaxations of plastics-bodied tapping tees are tested, as specified in GIS/LC8 4, the tapping tee shall meet the 50-year life requirement. However, the polyethylene main and service shall be pressurized to 5.5 bar \pm 0.15 bar after the main is tapped, and it is not necessary to maintain an air-flow during the test.

The test duration shall be 6 months in air at a temperature of 23 °C \pm 2 °C. The graph of average bolt load (F_m) versus log time shall show that the bolt load at 50 years shall exceed the bolt load at which leakage occurs.

The test shall be repeated for 3 months at a temperature of 80 °C \pm 2 °C, except it is not necessary to measure bolt load at leakage (F_l). The graph of average bolt load (F_m) versus log time shall be linear to demonstrate the validity of extrapolating the 23 °C data to 50 years.

9.11 Fire resistance (16 mm to 63 mm)

For the purposes of fire resistance, the leakage from the above ground, through-wall fitting (see 7.2.3), the below ground, through-wall fitting (see 7.2.4) and the service head adapter (see 7.2.5) shall not be greater than 0.14 m³/h when tested as specified in Annex I.

9.12 Sturdiness of metallic female threads (16 mm to 63 mm)

The socket on the fitting shall show no signs of damage or cracking after being mounted on a plug gauge as described in Annex J. The assembly shall remain leaktight in accordance with 9.3.

9.13 Long Term Resistance to Corrosion

GIS/PL3:2023

Below ground fittings and any above ground fittings where the metal parts might not be installed inside a building, must be tested to demonstrate long term resistance to corrosion as described in Annex N.

10. Type testing

10.1 General

Implementation of the tests specified in this specification shall be the responsibility of the manufacturer/contractor.

On the introduction of a new design or modification, the fitting shall be subjected to the relevant tests using polyethylene pipe conforming to GIS/PL2-2 (classes A and B) or GIS/PL2-8 (class C).

The requirements for type testing are to be included in the manufacturer's quality plan.

Type tests shall demonstrate that fittings conform to all the requirements for the properties given in Tables 5 or 6 before fittings are supplied to the gas transporter. The fitting shall not be retightened during any of the tests.

Testing shall either be carried out by the contractor and witnessed by the gas transporter, or carried out by an independent laboratory accredited to BS EN ISO/IEC 17025.

The test programme in accordance with Tables 5 or 6 shall be carried out on each fitting type and size that a contractor offers as conforming to this specification, except where a range of metallic-bodied fittings of exactly the same design, permits a reduced number of tests.

The test programme for metallic-bodied fittings only requires one fitting of each type and size to be tested, e.g. testing a 32 mm straight transition fitting would cover all the 32 mm fittings that use exactly the same polyethylene mechanical joint (service head adapters, meter box adapters, etc.). For fittings that have more than one fitting connection to polyethylene pipe, each fitting joint size shall have been fully tested.

The same size of metal-bodied fitting for use with pipe of SDR 11 to 17.6 is considered to be one fitting type but another type for SDR 21 and 26.

For approval of plastics-bodied fittings (16 mm to 63 mm), it is required that each fitting of each size, type and SDR is tested. Extension to the range for any single size shall require full testing.

Temporary, re-useable plastic-bodied mechanical fittings shall be tested in accordance with Annex O.

10.2 Size grouping for metallic-bodied and metal/polyethylene flanged fittings

For the purposes of this specification, the metallic-bodied fitting test groups in Table 4 apply to each fitting type/design. The groups also apply to metal/polyethylene flanged fittings. Where a fitting has a common design throughout a number of sizes, samples are to be taken from the smallest, largest and one intermediate size within each of the test groups.

The manufacturer shall define the product range in each test group and choose for testing evenly distributed sizes and SDRs over the full product range.

Table 4 — Test groups for metallic-bodied fittings and metal/polyethylene flanged fittings

Fitting class	Class A	Class B						Class C	
Pipe SDR	Corrugated	SDR 11 to 17.6			SDR 21 and 26			SDR 11	
Pipe size	16 to 40 mm	16 to 63 mm	75 to 225 mm	250 to 800 mm	16 to 63 mm	75 to 225 mm	250 to 800 mm	63 to 225 mm	225 to 500 mm
Test group	AS	B11S	B11M	B11L	B21S	B21M	B21L	C11M	C11L

10.3 Size grouping for plastics-bodied fittings

Plastics-bodied fittings are only for sizes 16 mm to 63 mm so there is only one size group. Each fitting of each size, type and SDR shall be tested.

10.4 Fitness for purpose

10.4.1 General

All fittings shall undergo the tests defined in Table 5 (metal-bodied and metal/polyethylene flanged fittings, 16 mm to 800 mm) or Table 6 (plastics-bodied, 16 mm to 63 mm). The fittings shall be assembled according to the requirements of Tables 5, 6, 7 and 8, which include minimum and maximum temperatures, plus minimum and maximum compression of the pipe wall (metal-bodied) or minimum diameter of the polyethylene pipe (plastics-bodied). Polyethylene flanged fittings shall not be required to be assembled at minimum and maximum compression of the pipe wall.

10.4.2 Temperature variations

Many of the fitting assemblies shall be assembled at a maximum of -5 °C and others at a minimum of +30 °C, in accordance with the manufacturer’s written instructions. Each half of the fitting assemblies shall undergo the tests, as appropriate, described in 9.1 to 9.12.

10.4.3 Maximum and minimum compression of the polyethylene pipe wall

Metal-bodied fittings, including metal-flanged fittings, shall be dimensioned to give the appropriate level of compression of the polyethylene pipe wall as specified in Annex K.

Plastics-bodied fittings for certain tests shall be tested with polyethylene pipe that has been machined to the specified minimum outside diameter, whilst maintaining the original surface finish of the polyethylene pipe as closely as possible.

Tapping tees mechanically attached to the polyethylene main, shall use the polyethylene main “as received” unless changes are required by the manufacturer as part of the assembly procedure in which case these shall be followed.

Table 5 — Properties of metal-bodied mechanical fittings and metal/polyethylene flanged fittings that require type testing (16 mm to 630 mm)

Property	Shall conform to	Sampling procedure ^{a)}	No./type of test pieces ^{b)}	No. of measurements per test piece	
Appearance	7.1	Three diameters/ test group	1	1	
Anti-shear sleeve (16 mm to 55 mm) ^{c)}	7.2.1	All sizes	1	1	
Strength of joint to steel sleeve ^{h)}	7.2.4, 7.2.5	All sizes	1	1	
Mechanical properties	20 °C short-term hydrostatic strength (1 h)	9.1	Three diameters/ test group	1 (polyethylene flanges) A, B, C, D ^{d)} (compression fittings)	1
	20 °C long-term hydrostatic strength (1 000 h)	9.2	Three diameters/ test group	1 (polyethylene flanges) A, B, C, D ^{d)} (compression fittings)	1
	Leaktightness ⁱ⁾	9.3, Annex A	Three diameters/ test group	1 (polyethylene flanges) A, B, C, D ^{d)} (compression fittings)	1
	Leaktightness with bending and temperature cycling (–20 °C to 40 °C) 16 mm to 63 mm	9.4, Annex B	Three diameters/ test group	1 (polyethylene flanges) A, B, C, D ^{d)} (compression fittings)	1
	Leaktightness with temperature cycling (–20 °C to 40 °C) 75 mm to 630 mm	9.5, Annex C	Three diameters/ test group	1 (polyethylene flanges) A, B, C, D ^{d)} (compression fittings)	1
	Leaktightness after tensile testing (23 °C) (all sizes)	9.6, Annex D	Three diameters/ test group	1 (polyethylene flanges) A, B, C, D ^{d)} (compression fittings)	1
	Leaktightness after constant load at 80 °C and tensile testing at 23 °C ^{e)} (all sizes)	9.7, Annex E	Three diameters/ test group	1 (polyethylene flanges) A, B, C, D ^{d)} (compression fittings)	1
	Hydrostatic strength at 80 °C (all sizes)	9.8, Annex F	Three diameters/ test group	1 (polyethylene flanges) A, B, C, D ^{d)} (compression fittings)	1
	Pressure drop (16 mm to 63 mm) ^{f), i)} (75 mm to 630 mm) ^{g)}	9.9.1, 9.9.2	All sizes	1	1
		9.9.1, 9.9.3	All sizes	1	1
	Fire resistance Below ground, through-wall and SHA (16 mm to 63 mm)	8.11, Annex I	Three diameters/ test group	1	1
	Sturdiness of metallic female threads (16 mm to 63 mm)	9.12, Annex J, 9.3	All sizes	1	1
Marking	12	Three diameters/ test group	1	1	

Table 5 — Properties of metal-bodied mechanical fittings and metal/polyethylene flanged fittings that require type testing (16 mm to 630 mm) (continued)

- a) Evenly distributed diameters over the product range shall be chosen. The product range in each size group shall be defined by the manufacturer. Samples shall comprise the smallest, largest and one intermediate diameter of the range manufactured. The test group is given in Table 4. Where a manufacturer extends production beyond approval, additional relevant type testing shall be carried out.
- b) The number of test pieces given in the table is the minimum. All test pieces shall pass the relevant test(s).
- c) Anti-shear sleeves are only required for straight transition fittings in sizes 16 mm to 55 mm.
- d) Assemble the compression fittings in accordance with the conditions defined in Table 7. For other fitting types e.g. polyethylene flanged fittings, where only one fitting is required for test then it shall be assembled at $23\text{ °C} \pm 2\text{ °C}$.
- e) Sometimes referred to as the accelerated relaxation and end load test (AREL).
- f) Applicable to all transition and above ground, through-wall fittings.
- g) Only requires measurement of bore dimensions.
- h) For below ground, through-wall fittings and service head adaptors only.
- i) Pressure drop through service tees are covered in GIS/F2.
- j) The leaktightness test also applies to an integral shut off valve, if fitted.

Table 6 — Properties of plastics-bodied mechanical fittings (16 mm to 63 mm) that require type testing

Property		Shall conform to	Sampling procedure ^a	Number/type of test pieces ^b	Number of measurements per test piece	
Appearance		7.1	All sizes	1	1	
Colour		7.7.1	All sizes	1	1	
Mechanical properties	20° C short-term hydrostatic strength (1 h)	9.1	All sizes	X, Y ^{c)}	1	
	20° C long-term hydrostatic strength 5 000 h (1 000 h - BRT)	9.2	All sizes	X, Y ^{c)}	1	
	Leaktightness	9.3, Annex A	All sizes	W, X, Y, Z ^{c)}	1	
	Leaktightness with bending and temperature cycling (–20° C to 40° C)	9.4, Annex B	All sizes	X, Y ^{c)}	1	
	Leaktightness after tensile testing (23° C)	9.6, Annex D	All sizes	W, X, Y, Z ^{c)}	1	
	Leaktightness after constant load at 80° C and tensile testing at 23° C ^d	9.7, Annex E	All sizes	W, X, Y, Z ^{c)}	1	
	Hydrostatic strength at 80° C	9.8, Annex F	All sizes	X, Y ^{c)}	1	
	Pressure drop (transition fittings only)	9.9.1, 9.9.2	All sizes	1	1	
	Moisture resistance (push-fit only)	9.10.1, Annex G	All sizes	1	1	
	Impact strength (couplers and elbows only)	9.10.2, Annex H	All sizes	1	1	
	Tapping tees	Impact strength	9.10.3	All sizes	1	See GIS/PL2-4
		Cap leakage	9.10.4	All sizes	1	See GIS/PL2-4
		Cutting torque	9.10.5	All sizes	1	See GIS/PL2-4
		Pressure drop	9.10.6	All sizes	1	See GIS/PL2-4
		Bolt relaxation	9.10.7	All sizes	1	See GIS/LC8-4
Marking		12	All sizes	1	1	

^{a)} The product range in each size group shall be defined by the manufacturer. Where a manufacturer extends production beyond approval, additional relevant type testing shall be carried out.

^{b)} The number of test pieces given in the table is the minimum. All test pieces shall pass the relevant test(s).

^{c)} Assemble the fittings in accordance with the conditions defined in Table 8. Where only one fitting is required for test then it shall be assembled at 23 °C ± 2 °C.

^{d)} Sometimes referred to as the accelerated relaxation and end load test (AREL).

Table 7 — Types of metal-bodied compression fitting assemblies

Fittings assembly type	Compression of the pipe wall ^{a)}	Pipe and fitting conditioning temperature
A	Minimum	-5 °C max.
B	Maximum	30 °C min.
C	Maximum	-5 °C max.
D	Minimum	30 °C min.

^{a)} Not required for polyethylene flanged fittings.

Table 8 — Types of plastics-bodied fitting assemblies (16 mm to 63 mm)

Fittings assembly type	Diameter of the pipe ^{a)}	Pipe and fitting conditioning temperature
W	Minimum	-5 °C max.
X	As received	30 °C min.
Y	As received	-5 °C max.
Z	Minimum	30 °C min.

^{a)} The outside of the pipe machined to the minimum outside diameter, whilst maintaining the original surface finish as closely as possible.

11. Batch release testing

The mechanical fitting manufacturer shall carry out a schedule of batch release testing (BRT) during production in accordance with Table 9.

The fitting shall not be retightened during any of the tests.

Table 9 — Properties and minimum sampling frequencies for BRT

Property	Clause	Minimum sampling frequency	No./type of samples ^{a)}	No. of measurements per sample
Visual defects ^{b), c)}	6	All fittings	1	1
Dimensions ^{d)}	6, 7	All fittings	1	1
Leakage ^{e)} (cast/welded metal bodies)	^{e)}	All fittings	1	1
Hydrostatic test at 80 °C, 1 000 h (plastics-bodied ≤ 63 mm only)	9.8, Annex F	Once per batch	1 ^{f)}	1
Marking	12	Once per batch	1	1

- a) The number of test pieces given in the table is the minimum. All test pieces shall pass the relevant test(s).
- b) All bodies of cast metal fittings shall be visually inspected, after machining, for freedom from unacceptable defects.
- c) All plastics-bodied fittings and polyethylene flanges shall be visually inspected, after machining if appropriate, for freedom from unacceptable defects.
- d) The contractor shall ensure that the materials and the dimensions of components conform to the fittings drawings that were approved for type testing.
- e) All bodies of cast and welded metal fittings, after machining, shall be subjected to a pneumatic pressure leakage test at a minimum pressure of 5.5 bar (class B), 7 bar (class C) or 1 bar (class A).
- f) Assemble the fittings at ambient temperature.

12. Approval re-validation

Where there has been a break in manufacture of a particular size and type of fitting for over 12 months, the manufacturer shall be required to re-validate the approval status.

The approval re-validation tests shall be conducted on each size and type of fitting requiring re-approval. If the size and type of fitting can be jointed to polyethylene pipe of more than one SDR, pipe of the thickest wall shall be used for the re-validation.

Table 10 — Properties and minimum sampling frequencies for approval re-validation

Property	Clause	Minimum sampling frequency	Number/type of samples ^{a)}	Number of measurements per sample
20 °C long-term hydrostatic strength (1 000 h)	9.2	Once after a 12 month manufacturing break (metal-bodied only)	1 ^{b), c)}	1
Leaktightness after constant load at 80 °C and tensile testing at 23 °C	9.7, Annex E	Once after a 12 month manufacturing break (metal-bodied and polyethylene flanges only)	1 ^{b), c)}	1

- a) The number of test pieces given in the table is the minimum. All test pieces shall pass the relevant test(s).
- b) Assemble the fittings at ambient temperature.
- c) If appropriate, the fitting shall be tested with the thickest pipe wall for which it is designed.

13. Marking

13.1 General

Unless stated otherwise in Table 11, the body of the fitting shall carry permanent markings, produced by moulding or by indent marking, that shall remain visible after assembly and shall include the information in Table 11. Such markings shall remain legible under normal handling, storage, weathering and installation.

Marking shall not initiate cracks or other types of defects, which adversely influence the performance of the fitting.

If printing is used, the colour of the printed information shall differ from the basic colour of the fitting.

The size of the marking shall be such that it is legible without magnification.

For polyethylene pipe sizes 16 mm and 20 mm, the actual SDR values are SDR 7 and SDR 9 respectively, due to minimum wall thickness considerations. However, the fittings shall be marked SDR 11.

13.2 Minimum required marking

The minimum required marking shall conform to Table 11.

Table 11 — Minimum required marking

Legend	Mark or symbol examples
The number and date of this specification, i.e. GIS/PL3:2023 ^{a), b)}	PL3
The name or trademark of the manufacturer or their appointed agent	Name or symbol
The manufacturer's contact details ^{a)}	Address
Where authorized, the product conformity mark of a third party certification body, e.g. BSI Kitemark	
Class A, B, C of fitting	Class B
Polyethylene pipe size and SDR	63 mm SDR 17.6
Pipe material and designation	PE80
Manufacturer's traceability: batch number or code ^{a)}	1234
Internal fluid ^{a)}	GAS
Transition fittings 75 mm to 630 mm – the size and material type compatibility of the metallic end ^{a)}	100 mm DI flange
Weight of the fitting in kilograms ^{a), c)}	15 kg
^{a)} The information may be printed on a label associated with the fitting or on a bag in which the fittings is stored. ^{b)} Marking GIS/PL3:2023 on or in relation to a product represents a manufacturer's declaration of conformity, i.e. a claim by or on behalf of the manufacturer that the product meets the requirements of the standard. The accuracy of the claim is therefore solely the responsibility of the person making the claim. Such a declaration is not to be confused with third party certification of conformity, which may also be desirable. ^{c)} Only required if fitting weight exceeds 10 kg.	

14. Assembly instructions

The contractor shall supply leaflets, in English, detailing assembly instructions and a diagram of the fitting. This shall include details of torque requirements, restraint requirements and any other pertinent assembly information. Assembly tools, if required, shall be listed together with their operating and maintenance instructions.

15. Packaging

The contractor shall ensure that individual fittings are suitably packaged so that their quality is not impaired during transit or storage. The package shall contain the assembly instructions.

Annex - A (normative) Leaktightness test method

Leaktightness testing shall be carried out in accordance with ISO 3458 with the exception that air or an inert gas shall be used as the pressurizing fluid instead of water. Testing shall be carried out at a temperature of $23\text{ °C} \pm 2\text{ °C}$ following the minimum test pressures and test times in Table A.1.

Plastics-bodied tapping tees shall be assembled onto polyethylene mains pipe, which have been previously horizontally bent to a radius of $25d_n$ – where d_n is the nominal outside diameter of the pipe.

In the interests of safety, the volume of the assembly may be reduced using a filler rod or suitable solid material. Adequate precautions shall be taken to provide protection to personnel should the assembly fail under pressure.

Table A.1 — Minimum test pressures and times for leaktightness test

Fitting class	Pipe SDR	Test 1		Test 2 ^{b)}	
		Pressure ^{c)} mbar	Time h	Pressure bar	Time h
A	All	25	1	1.0	1
B	SDR 11 ^{a)}	25	1	7.0	1
	SDR 13.6	25	1	6.0	1
	SDR 17.6	25	1	4.5	1
	SDR 21 and 26	25	1	3.0	1
C	SDR 11 ^{a)}	25	24	7.0	24

^{a)} For pipe sizes 16 mm and 20 mm, the actual SDRs are SDR 7 and SDR 9 respectively due to minimum wall thickness requirements.

^{b)} Test 2 shall be conducted as soon as possible after test 1.

^{c)} If the fitting is submerged in water to detect leakage, then the 25 mbar air test pressure shall be increased to compensate for the external water pressure, e.g. 250 mm water depth produces an external pressure of 25 mbar.

Annex - B (normative) Leaktightness with bending and temperature cycling (16 mm to 63 mm)

B.1 Principle

This test method assesses if the fitting assembly leaks after subjecting it to bending and a temperature cycling programme. There are two methods for the temperature cycling, depending on the availability of equipment.

B.2 Apparatus

B.2.1 *Temperature-regulated chambers, with an accuracy of ± 2 °C (one or two are required).*

B.2.2 *Bending gauge, conforming to ISO 3503.*

B.2.3 *Pressurizing system, conforming to BS EN 921.*

B.3 Procedure A – leaktightness test

In accordance with ISO 3503, carry out a test of leakproofness under internal hydraulic pressure when subject to bending on a fitting that has been assembled with straight polyethylene pipe.

B.4 Procedure B – temperature cycling test

B.4.1 General

If no leakage occurs when procedure A is carried out, then subject the fitting assembly (maintaining the bend), at an internal hydraulic pressure of 6 bar, to 10 successive complete temperature cycles. Use either method 1 or 2, though in the case of dispute, the two-chamber temperature cycle shall be used (method 1).

B.4.2 Method 1 – two temperature-regulated chambers

- a) Place the fitting in the first chamber at +40°C for at least 2.5 h.
- b) Transfer the fitting assembly to the second chamber at –20°C. Ensure the transfer time is 0.5 h to 1 h.
- c) Leave the fitting in the second chamber at –20 °C for at least 2.5 h.
- d) Transfer the fitting assembly to the first chamber at +40 °C. Ensure the transfer time is 0.5 h to 1 h.
- e) Return to a).

B.4.3 Method 2 – one temperature-regulated chamber

- a) Increase the temperature of the chamber to +40°C at a minimum rate of 1 °C/min.
- b) Maintain at +40°C for at least 2 h.
- c) Reduce the temperature to –20 °C at a minimum rate of 1 °C/min.
- d) Maintain at –20 °C for at least 2 h.
- e) Return to a).

B.5 Leaktightness test

After the 10 temperature cycles, check the fitting assembly for leaks at (23 ± 2) °C according to 9.3.

B.6 Expression of results

No hydraulic or pneumatic leakage shall occur.

Annex - C (normative) Leaktightness with temperature cycling (75 mm to 800 mm)**C.1 Principle**

This test method assesses if the fitting assembly leaks after subjecting it to a temperature cycling programme. There are two methods for the temperature cycling, depending on the availability of equipment.

C.2 Apparatus

C.2.1 *Temperature-regulated chambers, with an accuracy of ± 2 °C (one or two are required).*

C.2.2 *Pressurizing system, conforming to BS EN 921.*

C.3 Procedure A – leaktightness test

Assemble the fitting according to Clause 7.

Ensure the fitting assembly first fulfils the pneumatic leaktightness requirements in 9.3.

C.4 Procedure B – temperature cycling test**C.4.1 General**

If there is no leakage from procedure A, subject the fitting assembly, at an internal hydraulic pressure of 6 bar, to 10 successive complete temperature cycles. Use either method 1 or 2, though in the case of dispute, the two-chamber temperature cycle shall be used (method 1).

C.4.2 Method 1 – Two temperature-regulated chambers

- a) Place the fitting in the first chamber at +40 °C for at least 2.5 h.
- b) Transfer the fitting assembly to the second chamber at –20 °C. Ensure the transfer time is 0.5 h to 1 h.
- c) Leave the fitting in the second chamber at –20 °C for at least 2.5 h.
- d) Transfer the fitting assembly to the first chamber at +40 °C. Ensure the transfer time is 0.5 h to 1 h.
- e) Return to a).

C.4.3 Method 2 – One temperature-regulated chambers

- a) Increase the temperature of the chamber to +40 °C at a minimum rate of 1 °C/min.
- b) Maintain at +40°C for at least 2 h.
- c) Reduce the temperature to –20 °C at a minimum rate of 1 °C/min.
- d) Maintain at –20 °C for at least 2 h.
- e) Return to a).

C.5 Leaktightness test

After the 10 temperature cycles, check the fitting assembly for leaks at (23 ± 2) °C according to 9.3.

C.6 Expression of results

No hydraulic or pneumatic leakage shall occur.

Annex - D (normative) Leaktightness after tensile testing at 23 °C

D.1 Principle

A fitting assembly is subjected to a tensile test at a specified constant speed until the pipe yields. The leaktightness at 25 mbar is verified before and after the tensile test.

D.2 Apparatus

D.2.1 *Room, which can be maintained at a temperature of 23 °C ± 2 °C.*

D.2.2 *Tensile testing machine, or other equipment sufficiently powerful to allow tests to be carried out up to the yield point of the polyethylene pipe. The machine shall be capable of sustaining, between its clamping jaws, a constant force with a maximum variation of 5 % and a constant speed of 25 mm/min ± 10 mm/min.*

D.2.3 *Clamping devices for holding a fitting assembly.*

D.2.4 *Force-measurement device, capable of checking conformity with D.2.2.*

D.2.5 *Stopwatch, or similar timing device.*

D.2.6 *Class 1.6 recording manometer, (0 mbar to 60 mbar) as specified in BS EN 837-1.*

D.2.7 *Compressed air supply.*

D.2.8 *Set of pipes, equipped with valves that can be used to connect the fitting assembly to the manometer and the pressure supply or to isolate the fitting/manometer unit from the pressure supply.*

D.3 Preparation for in-line connections

For each fitting, use polyethylene pipe(s) of free length (not counting the fitting and the clamping jaws) equivalent to at least two times the nominal diameter of the pipe.

Reinforce, by means of a stiffener insert, the free end of the polyethylene pipes that are to be clamped in the jaws of the tensile-testing machine.

Attach seals to the free ends of the pipes so that the fitting assembly will remain leaktight at a pressure of 25 mbar. It is necessary to connect one of the ends to the pressure supply.

Condition the fitting assembly at 23 °C ± 2 °C for 2 h (metal-bodied fittings) or 4 h (plastics-bodied fittings).

Clamp the ends of the fitting assembly in the jaws of the tensile testing machine such that the line of the force is along the axis of the pipe.

NOTE It is permissible to conduct the 25 mbar leaktightness pressure test before clamping the fitting assembly in the tensile testing machine.

Connect the fitting assembly to the pressure supply and introduce a pressure of 25 mbar into the assembly.

Isolate the fitting assembly from the pressure supply and check for leaktightness of the assembly.

Load the test assembly as specified in D.5

D.4 Preparation for lateral connections (mechanically attached tapping tees)

For each fitting, use a lateral polyethylene pipe of free length equivalent to at least five times the outside diameter of the pipe, but a maximum of 250 mm.

Reinforce, by means of a stiffener insert, the free end of the polyethylene pipes that are to be clamped in the jaws of the tensile-testing machine. Externally support the polyethylene main.

Attach seals to the free ends of the pipes so that the fitting assembly will remain leaktight at a pressure of 25 mbar. It is necessary to connect one of the ends to the pressure supply.

Condition the fitting assembly at $23\text{ °C} \pm 2\text{ °C}$ for 4 h.

Clamp the ends of the fitting assembly in the jaws of the tensile testing machine such that the line of action of the force is along the axis of the lateral polyethylene pipe. The polyethylene main shall be restrained to allow the lateral pipe to remain on-centre. A typical arrangement is shown in Figure D.1.

NOTE It is permissible to conduct the 25 mbar leaktightness pressure test before clamping the fitting assembly in the tensile testing machine.

Connect the fitting assembly to the pressure supply and introduce a pressure of 25 mbar into the assembly.

Isolate the fitting assembly from the pressure supply and check for leaktightness of the assembly.

Load the test assembly in the tensile testing machine as specified in D.5

D.5 Tensile testing to yield

Apply the tensile force using a crosshead speed of $25\text{ mm/min} \pm 10\text{ mm/min}$ until yield of the polyethylene pipe or lateral pipe occurs. If the free polyethylene pipe length is greater than twice the nominal outside diameter increase the crosshead speed proportionally.

Reduce the tensile force to zero and then pressurize the assembly with air to 25 mbar and check the leaktightness of the assembly for 1 h.

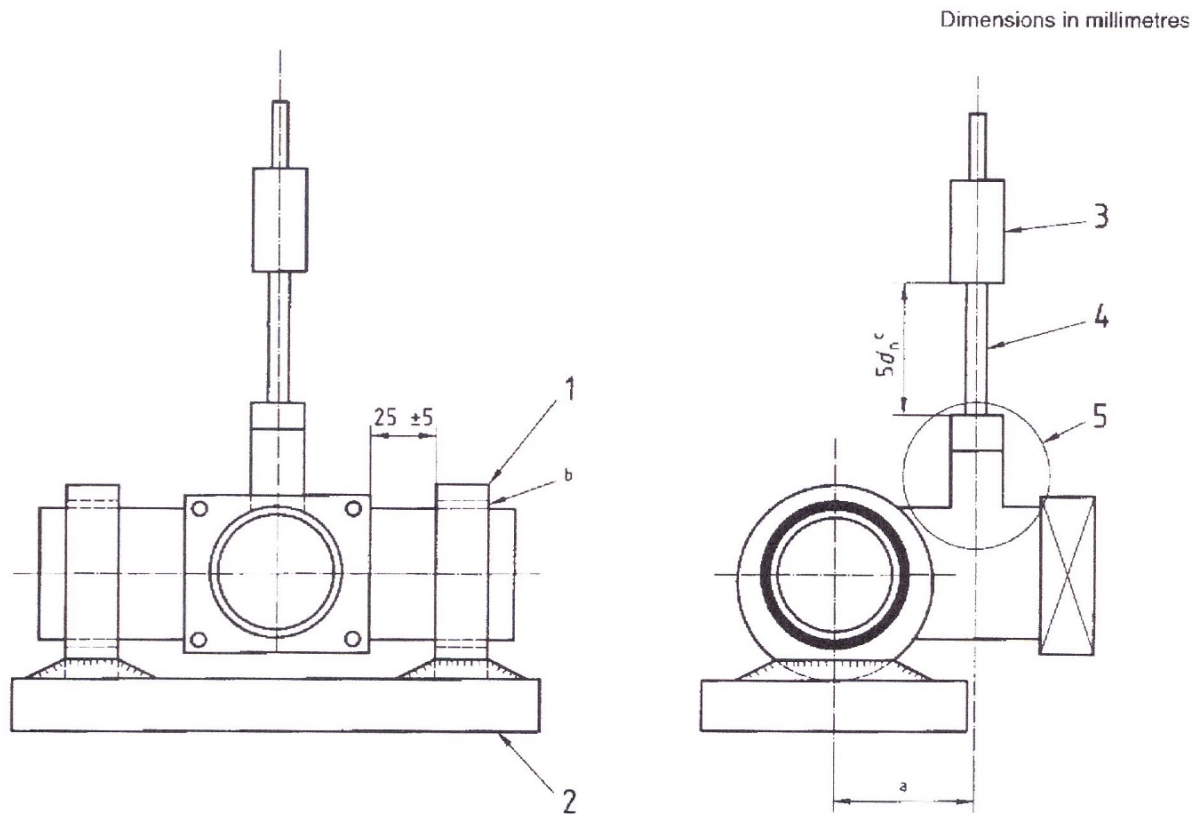

Key

- 1 Steel rings attached to steel base
 - 2 Steel plate mounted in tensile-testing machine
 - 3 Crosshead of tensile-testing machine
 - 4 Lateral PE pipe
 - 5 Tee under test
- a Offset from lateral centreline to centre of main pipe
 b Gap to allow tee and pipe to rotate
 c Nominal outside diameter

Figure D.1 — Typical arrangement for applying a tensile force to a lateral connection

Annex - E (normative) Leaktightness after constant load at 80 °C and tensile testing at 23 °C

E.1 Principle

A fitting assembly is first subjected to a specific longitudinal stress by application of a constant load at 80 °C, and subsequently to extension at a specified constant speed at 23 °C until the pipe yields. The leaktightness is verified at the end of the test.

The test simulates relaxation of the plastic and rubber parts for the 50 year design life and indicates any possibility of stress crack initiation in the polyethylene pipe particularly from sharp grip rings. The full-end-load resistance is then determined after this simulated life by ensuring the pipe yields before pull-out or failure from stress cracking and that the pipe joint is still leaktight.

E.2 Apparatus

E.2.1 *Equipment to apply a constant tensile load, with an accuracy of ± 5 %.*

E.2.2 *Water bath, at a temperature of (80 ± 5) °C.*

E.2.3 *Tensile testing equipment, with a measurement accuracy of ± 3 %.*

E.3 Test specimen

For each fitting, use polyethylene pipe of length (not counting the fitting and the clamping jaws) equivalent to at least two times the nominal outside diameter of the pipe.

Mount the fitting assembly in a fixture capable of applying a constant tensile force to the pipe(s) and fitting. The fitting shall be held in such a way that no distortion or support of any of the fitting components can occur.

E.4 Procedure A – constant load at 80 °C

Suspend the fitting assembly in the 80 °C water bath to condition for 1 h. The assembly does not have to be sealed and so water in the bore of the assembly is permitted.

Then subject the assembly to a longitudinal forces (end load) in accordance with Table E.1 applied gradually within a time period of $5 \text{ min} \pm 1 \text{ min}$ and then maintain for:

- class A – 500 h;
- class B – 500 h (sizes < 355 mm); 340 h (sizes \geq 355 mm);
- class C – 500 h (sizes < 355 mm); 340 h (sizes \geq 355 mm).

Remove from the water bath and condition for 24 h at $23 \text{ °C} \pm 2 \text{ °C}$.

E.5 Procedure B – tensile test to yield

After carrying out procedure A, conduct a tensile test at $23 \text{ °C} \pm 2 \text{ °C}$ on the assembly at a crosshead speed of $25 \text{ mm/min} \pm 10 \text{ mm/min}$ until yield of the polyethylene pipe occurs. If the free polyethylene pipe length is greater than twice the nominal outside diameter increase the crosshead speed proportionally.

Reduce the tensile force to zero.

E.6 Procedure C – leaktightness at 23 °C

After the completion of the tensile pull-out test (procedure B), condition the fitting assembly for 24 h at $23 \text{ °C} \pm 2 \text{ °C}$, then conduct a pneumatic leaktightness test in accordance with 9.3 and Annex A.

E.7 Expression of results

Procedure A – no pull-out of the pipe from the fitting shall occur. No evidence of cracking of the fitting or pipe shall occur.

Procedure B – no pull-out of the pipe from the fitting shall occur. No evidence of cracking of the

fitting or pipe shall occur.

Procedure C – no pneumatic leakage shall occur.

NOTE Displacement of trapped air from the free space within the fitting assembly, i.e. seal burping, is not considered leakage.

Table E.1 — End load requirements at 80 °C

Fitting size mm	Minimum end load ^{a)} kN						
	Class B						Class C
	SDR 11 PE80	SDR 13.6 PE80	SDR 17.6 PE80	SDR 21 PE80	SDR 21 PE100	SDR 26 PE80	SDR 11 PE100
16	0.35	—	—	—	—	—	—
20	0.45	—	—	—	—	—	—
25	0.57	—	—	—	—	—	—
32	0.96	—	—	—	—	—	—
40	1.48	—	—	—	—	—	—
50	2.30	—	1.50	—	—	—	—
55	2.80	—	—	—	—	—	—
63	3.65	3.0	2.35	2.00	2.35	—	4.35
75	5.0	3.0	3.35	—	—	—	6.0
90	7.5	—	5.0	4.05	4.85	—	9.0
110	11.0	—	7.0	6.0	7.0	—	13.0
125	14.0	—	9.0	8.0	9.5	—	17.0
140	18.0	—	11.5	—	—	8.0	21.5
160	—	—	15.0	12.5	15.5	10.5	—
180	29.5	—	19.0	16.0	19.5	13.5	35.5
200	36.5	—	23.5	20.0	24.0	16.5	43.5
213	—	—	—	—	—	18.5	—
225	—	—	—	25.0	30.5	20.5	—
250	57.0	—	37.0	31.0	37.5	25.5	68.0
268	—	—	—	—	—	29.0	—
280	71.0	—	46.0	—	—	32.0	85.5
315	90.0	—	58.5	49.5	59.5	40.5	108.0
355	81.8	—	53.0	45.0	67.5	—	122.7
400	103.9	—	67.4	57.0	85.5	—	155.8
450	131.5	—	85.2	72.0	108.0	—	197.0
469	—	—	—	78.2	117.5	—	—
500	162.5	—	105.2	89.0	133.5	—	243.5
560	203.6	—	132.0	112.0	168.0	—	—
630	257.7	—	167.0	141.5	212.0	—	386.4
800	—	—	—	—	341.9	—	—
<p>NOTE 1 Fitting sizes 16 mm and 20 mm use pipe of SDR 7 and SDR 9 respectively due to minimum wall thicknesses.</p> <p>NOTE 2 The stresses to calculate the end loads are:</p> <ul style="list-style-type: none"> — PE80 < 355 mm, approximately half yield stress at 80 °C, i.e. 3.5 MPa; — ≥ 355 mm, 2.5 MPa; — PE100 < 355 mm, approximately half yield stress at 80 °C, i.e. 4.2 MPa; — ≥ 355 mm, 3.75 MPa. 							
<p>^{a)} For all class A fittings, the end load shall be 50 N.</p>							

Annex - F (normative) Hydrostatic strength at 80 °C

F.1 Principle

This test assesses the strength of the fitting assembly at 80 °C. By monitoring water leakage, it also determines long-term resistance to creep and stress cracking by accelerating the mechanisms through the elevated temperature.

F.2 Procedure

Conduct the test in accordance with BS EN 921 using a water test temperature of 80 °C ± 1 °C and with the fitting assembly unrestrained during the test. End caps are Type A.

Apply an appropriate hydraulic pressure for the test times in Table F.1.

Monitor the water leaktightness of the assembly during this period.

For type testing of plastics-bodied fittings, section and suitably prepare the assembly after testing. Ensure there is no evidence of stress cracking or pipe failure when the joint is examined using dye penetrant or other equivalent methods.

F.3 Expression of results

No water leakage shall occur.

Table F.1 — Hydrostatic strength at 80 °C test pressures and associated test periods for class A, B and C fittings

Fitting type	Stress MPa	Pressure bar					Time h
		SDR 11	SDR 13.6	SDR 17.6	SDR 21	SDR 26	
Class A	—	1.40	—	—	—	—	1 000
Class B	4.0	8.00	6.00	4.82	4.00	3.20	1 000
Class C	5.0	10.00	—	—	5.00	—	1 000

Annex - G (normative) Moisture resistance (plastics-bodied, push-fit)**G.1 Principle**

Plastics-bodied, push-fit mechanical fittings rely on two main seals (normally rubber “O” rings) against the outside of the polyethylene pipe. During service there will be continual expansion and contraction of the polyethylene pipe due to:

- a) pipe temperature changes underground;
- b) ground movement;
- c) cyclic loading by vehicles above ground;
- d) interference.

This pipe movement relative to the “O” rings creates a rubbing action. If there is water ingress into the seal area this will bring dirt and grit with it, which may over long periods cause the relatively soft rubber seal to wear away and leak. An external water/moisture seal is required.

The test method ensures the effectiveness of the external water/moisture seal.

G.2 Apparatus

G.2.1 *Water bath, at a temperature of (20 ± 5) °C.*

G.2.2 *Activated silica gel crystals, to detect moisture by a colour change.*

G.2.3 *Rubber bung, to fit the pipe bore*

G.3 Test specimen

Assemble the plastics-bodied, push-fit fitting with a minimum 1 m length of polyethylene pipe conforming to GIS/PL2-2, but omitting the main seal(s).

Fill the bore of the assembly near the fitting with activated silica gel and seal the pipe end with a rubber bung.

G.4 Procedure

Immerse the fitting under test at a depth of not less than 750 mm in the water bath for 24 h. Keep the other end of the polyethylene pipe clear of the water.

Remove the assembly from the water bath and dry it externally.

Remove the rubber bung and remove the activated silica gel.

Check for evidence of water leakage past the moisture seal into the fitting by the colour change of activated silica gel.

G.5 Expression of results

There shall be no evidence of a colour change of the activated silica gel to indicate water leakage past the moisture seal.

Annex - H (normative) Impact strength (plastics-bodied couplers and elbows)**H.1 Principle**

This test ensures the plastics-bodied fitting will not break easily under normal field conditions. The requirements are similar to those for the body of an electrofusion tapping tee conforming to GIS/PL2 4.

H.2 Apparatus

The assembly to be tested shall be supported in a V-groove of a rigid frame and so mounted that the blow will be struck normally to the surface under test. The striking head shall be arranged to give an impact energy of 100 J. Figure H.1 shows a typical impact test assembly.

H.3 Test specimen

The test specimen shall consist of a plastics-bodied fitting assembled in accordance with the manufacturer's instructions to lengths of polyethylene pipe conforming to GIS/PL2-2.

A length of pipe equal to at least one pipe diameter shall protrude from each end of the fitting.

H.4 Test procedure

Condition the assembly at $-5\text{ °C} \pm 2\text{ °C}$ for at least 1 h prior to testing.

Carry out testing at $23\text{ °C} \pm 2\text{ °C}$ and complete it within 5 min of removing the assembly from the conditioning chamber.

Support the assembly in the V-groove.

Impact the fitting with the falling weight.

Ensure the impact direction is perpendicular to the pipe axis and that the falling weight strikes the fitting normal to the surface under test.

Ensure the falling weight has a mass of $5.0\text{ kg} \pm 0.1\text{ kg}$ and a hemispherical striking face of 25 mm diameter made of hardened steel.

Release the weight from a height of 2 m and ensure it strikes the centre of the fitting.

Turn the specimen 180° and impact on the opposite side.

On completion of the test, subject the fitting to a minimum 2 bar pneumatic pressure test for 1 h.

H.5 Expression of results

No leakage shall occur.

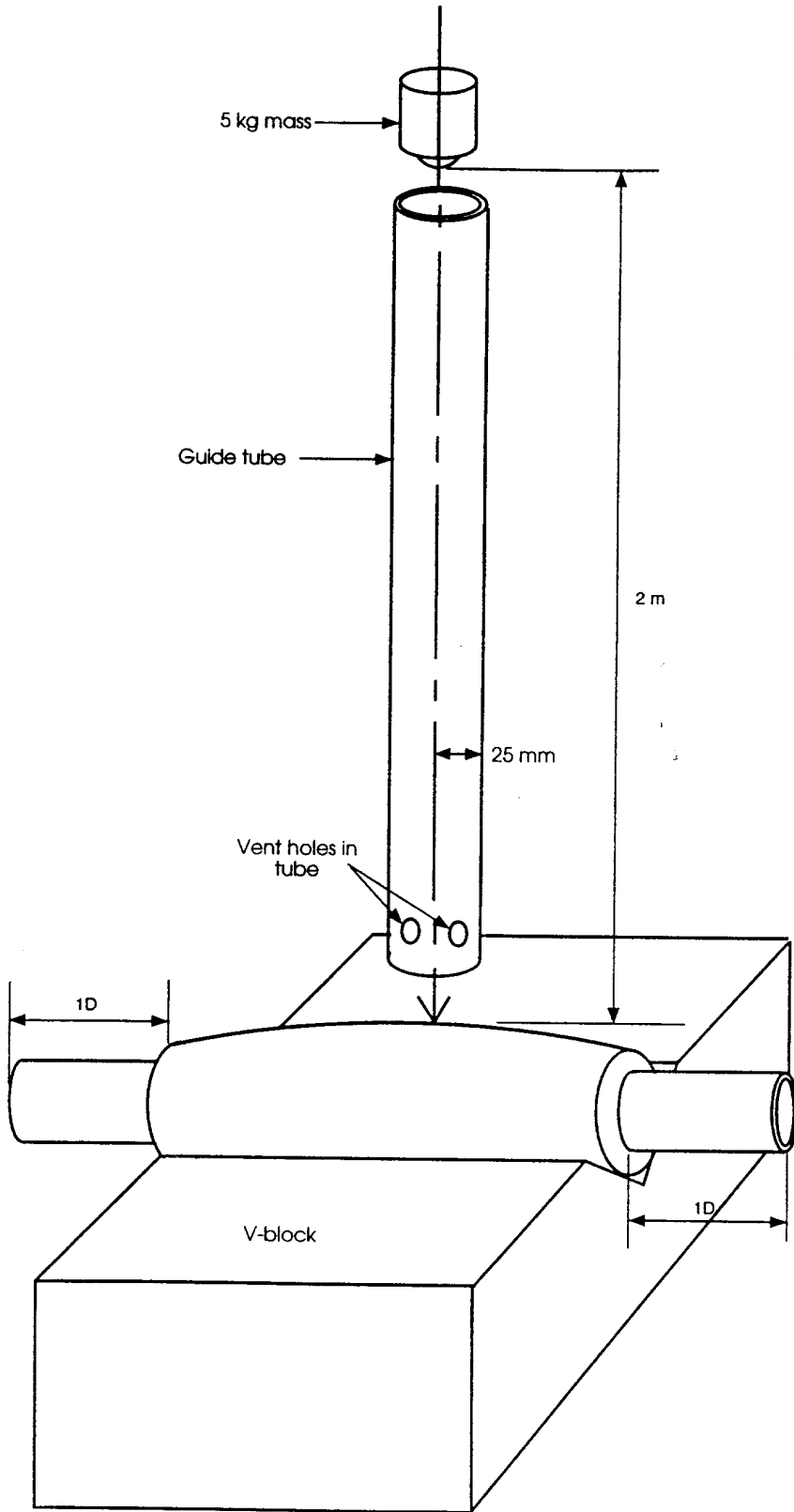

Figure H.1 — Typical impact assembly

Annex - I (normative) Fire resistance

I.1 Principle

Certain fittings that take the polyethylene pipe inside the building have to demonstrate that in the event of a fire only minimal gas leakage can escape from the fitting assembly. Any significant gas leakage has to be ducted down the steel sleeve encasing the polyethylene pipe and outside the building.

I.2 Apparatus

I.2.1 *Furnace, capable of an 821K rise over 30 mins in accordance with ISO 834-1 heating curve.*

I.2.2 *Water bath and measuring flask, to determine the leakage rate.*

I.3 Test specimen

A fitting shall be assembled in accordance with the contractor's approved written instructions with a short length of polyethylene pipe conforming to GIS/PL2-2 and a length of steel encasing sleeve. The lengths of the polyethylene pipe and steel encasing sleeve shall be 100 mm ± 5 mm and 150 mm ± 10 mm respectively.

The other end of the steel sleeve shall be prepared so that it can be capped off easily after the fire test, e.g. threaded.

I.4 Procedure

Test the whole fitting assembly in the furnace, increase the temperature by 821 K in 30 min in accordance with the curve specified in ISO 834-1 (aligned with the heating in BS EN 1775 Annex A Procedure A). After this period, remove the fitting assembly and allow to cool naturally to room temperature.

The polyethylene pipe will burn and the fumes will need to be dealt with by a suitable extraction system.

After capping off the steel encasing sleeve and the outlet of the fitting, pneumatically pressurize the assembly to 75 mbar and maintain at this pressure.

Measure the leakage rate from the fitting and the joint to the steel encasing sleeve. Collecting the leaking air bubbles in a measuring flask below water is a suitable method. Ignore leakage from the joint to the steel encasing sleeve.

I.5 Expression of results

The measured leakage rate shall be in cubic metres per hour.

Report if the leakage rate exceeds 0.14 m³/h.

Annex - J (normative) Sturdiness of female internal threads (16 mm to 63 mm)

J.1 Principle

This test method assesses the strength of internally (female) threaded parts of fittings. The male mating thread is tapered so, on assembly, the female part may result in cracking and bursting if it is too weak.

J.2 Apparatus

J.2.1 *Tapered plug gauge, conforming to ISO 7-2.*

J.2.2 *Torque wrench, with a torque range suitable for the thread size.*

J.3 Procedure

Screw the fitting on to a tapered plug gauge conforming to ISO 7-2 and tighten it by hand.

Tighten the fitting up to the applicable torques given in Table J.1 using the torque wrench.

Do not use lubricant for this test.

Check the fitting assembly for pneumatic leaks by testing in accordance with 9.3.

J.4 Expression of results

No cracking of the internal threaded part shall occur.

No pneumatic leakage from the threaded joint shall occur.

Table J.1 — Torque for testing female internal threads

Fitting size mm	Torque N·m	
	Steel and cast iron	Copper alloy
16	85	50
20	150	80
25	235	115
32	385	150
40	600	175
50	800	210
55	850	230
63	1 000	250

Annex - K (normative) Machining to create maximum or minimum pipe wall compression

To obtain samples giving the maximum or minimum polyethylene pipe wall percentage compression, the pipe wall thickness is first measured at four equally spaced positions around the circumference and the average thickness, t , is calculated (see Figure K.1).

If the fitting body bore is to be machined to create maximum or minimum percentage compression of the pipe wall, the outside diameter of the pipe insert, A , is measured (see Figure K.1).

For maximum compression,
$$B = A + \frac{t}{t_x} (B_n - A_x)$$

For minimum compression,
$$B = A + \frac{t}{t_n} (B_x - A_n)$$

Alternatively, if the outside diameter of the pipe insert is to be machined to create maximum or minimum compression of the pipe wall, the bore of the fitting body, B , is measured (see Figure K.1).

For maximum compression,
$$A = B + \frac{t}{t_x} (B_n - A_x)$$

For minimum compression,
$$A = B + \frac{t}{t_n} (B_x - A_n)$$

where:

A_x is the maximum outside diameter of pipe insert;

A_n is the minimum outside diameter of pipe insert;

B_x is the maximum bore of fitting body which is in contact with the pipe when assembled;

B_n is the minimum bore of fitting body which is in contact with the pipe when assembled;

t_x is the maximum pipe wall thickness specified in GIS/PL2-2 or GIS/PL2-8;

t_n is the minimum pipe wall thickness specified in GIS/PL2-2 or GIS/PL2-8.

Equivalent alternative methods of creating maximum or minimum percentage compression of the polyethylene pipe wall, appropriate to the design of the fitting, may be proposed by the contractor for consideration as a variant by the gas transporter. In such cases the detailed method, including calculations, shall be included in the test report.

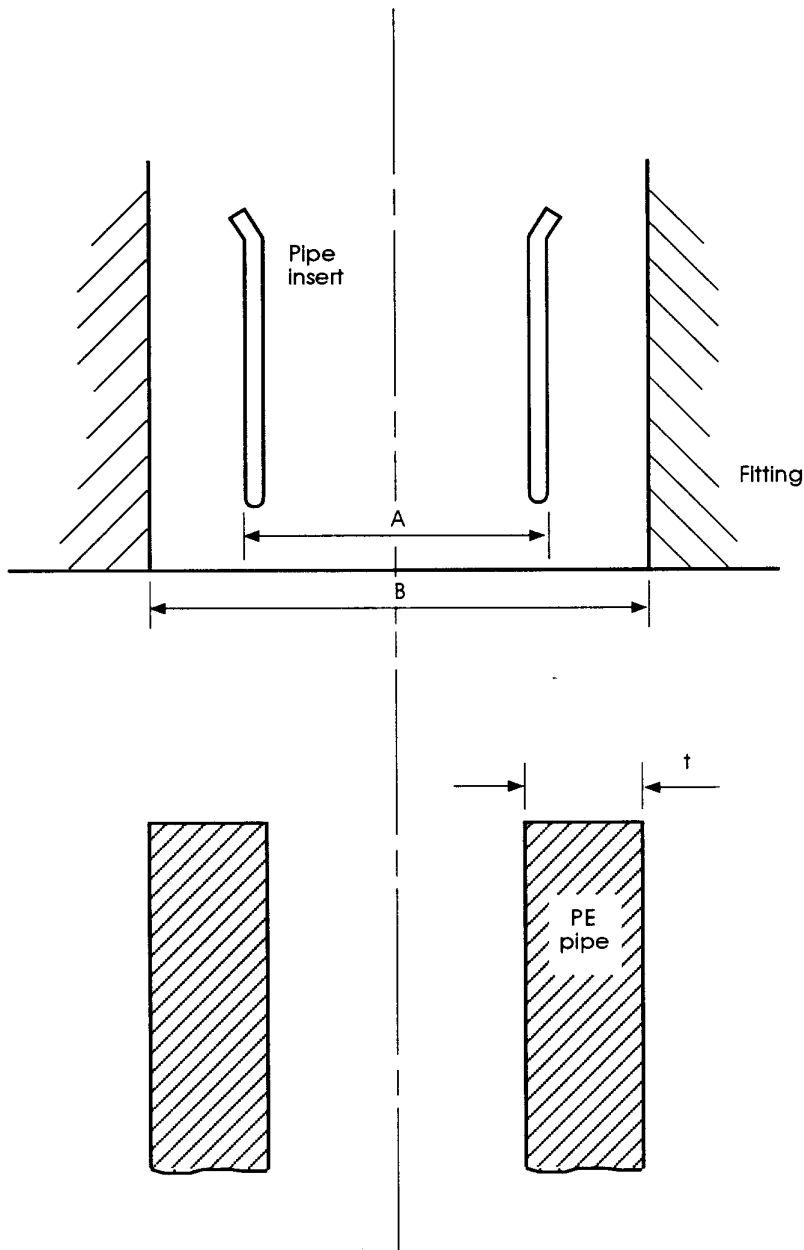

Figure K.1 — Dimensions for machining fitting body or pipe insert

Annex - L (normative) Long-term pressure test – assembly of fittings that form a gas seal on the external surface of polyethylene pipe

L.1 Principle

Where a gas tight seal is made on the external surface of a polyethylene pipe, it is important that an effective seal can be made onto pipes that have a certain degree of external surface damage. Consequently, the fitting is assembled with pipe samples that have four axial notches machined into the surface to simulate pipe surface damage to ensure that leakage from the fitting joint still does not occur.

L.2 Apparatus

Notching or broaching equipment, to produce the required notch shape and depth.

L.3 Procedure

Machine, using the notching or broaching equipment, four longitudinal notches on the external surface of the polyethylene pipe samples in accordance with Figure L.1.

Ensure that the depth of the notch is between 9 % and 10 % of the pipe nominal wall thickness (e_n) and that the included angle of the notch is between 19° and 21° .

Ensure the notch extends from the polyethylene pipe end and is visible when the fitting is assembled.

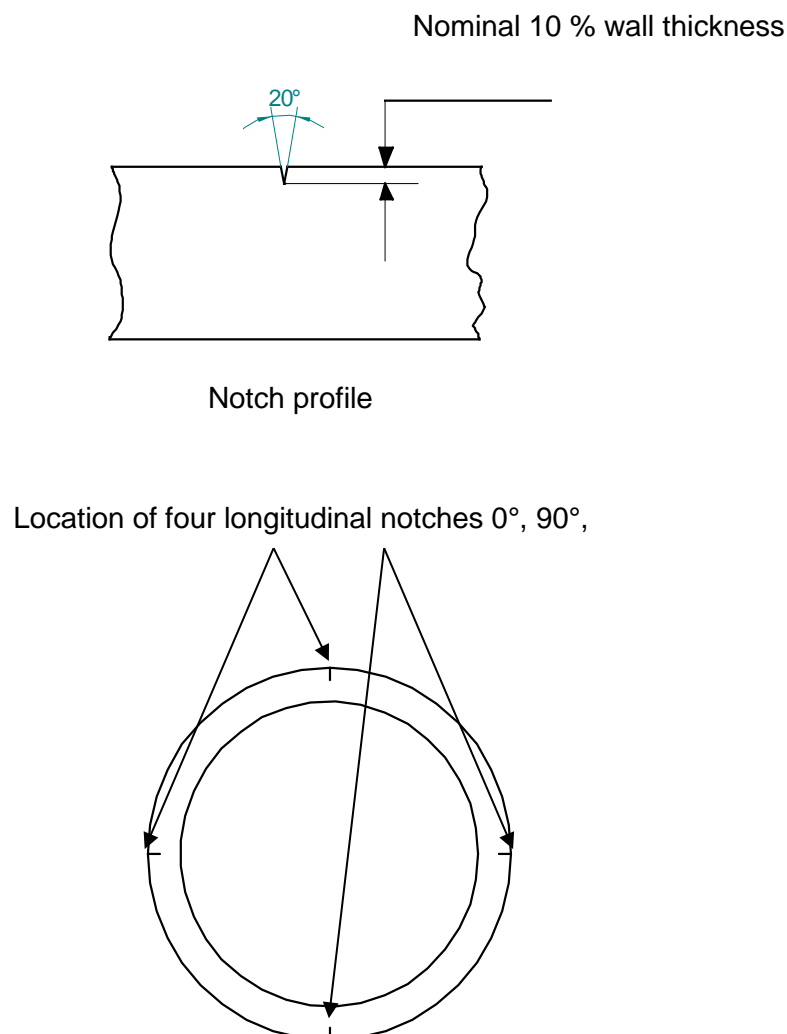

Figure L.1 — Notches in polyethylene pipe

Annex - M (normative) GRP service riser covers for polyethylene pipes

M.1 Dimensions:

For 25 mm polyethylene, GRP riser cover:

- inside diameter, $32.75 \text{ mm} \pm 0.5 \text{ mm}$;
- outside diameter, $38.1 \text{ mm} \pm 0.25 \text{ mm}$.

For 32 mm polyethylene, GRP riser cover:

- inside diameter, $38.5 \text{ mm} \pm 0.5 \text{ mm}$;
- outside diameter, $43.85 \text{ mm} \pm 0.25 \text{ mm}$.

Annex - N (normative) Long Term Resistance to Corrosion Test

Below ground fittings and any above ground fittings where the metal parts may not be installed inside a building, must undergo 1000 hours exposure to salt spray in accordance with ASTM B117. After exposure, no more than 5% of the surface area of the test samples shall exhibit red rust.

(Note: White corrosion deposits are acceptable.)

Annex - O (normative) Materials, design, performance and testing requirements for temporary, re-usable plastic-bodied fittings Class T

O.1 General

This annex applies to temporary, re-usable plastics-bodied mechanical fittings in the nominal size range 16 mm to 180 mm inclusive.

The temporary plastics-bodied fittings are Class T to denote they are Temporary, re-usable plastics-bodied mechanical fittings.

These mechanical fittings are designed to be temporarily attached to the end of a polyethylene (PE) gas pipe or PE spigot outlet. They are intended for use with PE pipe conforming to GIS/PL2-2 and spigot outlets conforming to GIS/PL2-6. Materials shall be in accordance with Clause 6 except where otherwise stated. Since these fittings are not used below ground Clause 6.2.a does not apply.

Packaging requirements shall be in accordance with Clause 15.

Class T fittings shall be suitable for use with pipe of SDR11, SDR13.6, SDR17.6, SDR21 or SDR26 having the same nominal diameter and conforming to GIS/PL2-2. The maximum operating pressure (MOP) and strength test pressures (STP) are in Table O.1. The fittings shall be designed for use up to a maximum period of 168 hours per installation.

Table O.1 — Class T maximum operating pressures and strength test pressures

Polyethylene pipe/Spigot SDR	MOP bar	STP bar
11	5.5	8.3
13.6	4.0	6.0
17.6	3.0	4.5
21	2.0	3.0
26	2.0	3.0

They shall be capable of assembly over the range -5 °C to +30 °C and be suitable for service operating temperatures from -20 °C to +40 °C.

The temporary plastics-bodied fittings are designed to be re-used at least 50 times, provided the condition and suitability for further use is checked after each operation. Certain components, such as the elastomeric seal(s), grip rings, or locking nuts, may be replaced if necessary.

O.2 Types of temporary fittings

- a) End caps – these are the fittings used to blank off the end of the PE pipe.
- b) Mechanical couplers – these are fittings, either straight or elbow, that join two PE pipes.
- c) Transition fittings – these are fittings, either straight or elbow, that join a PE pipe to a metal threaded outlet.

O.3 Design of temporary plastics-bodied fittings (16 mm to 180 mm)

O.3.1 General

The PE pipe to which the temporary fitting is being mechanically attached may be chamfered internal and / or externally to ease assembly. The external chamfer shall not interfere with subsequent electrofusion jointing. A lubricant may also be applied to the seals, but it shall be approved first by the end user to ensure there is no long-term detriment to the PE pipe or the fitting components.

Each fitting assembly shall not damage the PE pipe or spigot outlet to such an extent that an electrofusion joint cannot subsequently be made i.e. the damage depth shall be limited up to and including 10% wall thickness. Scraping is required before electrofusion in order to remove any lubrication or minor damage on the outer surface of the PE pipe.

Note: As an alternative, the manufacturer may state that any damage to the PE pipe end shall be cut off before making

an electrofusion joint as part of the written procedure. This is generally not applicable to tapping tee outlets as there is usually insufficient spigot length.

As the temporary fitting is not used below ground, the restriction to the small range of copper alloy components does NOT apply (see Clause 7.2).

O.3.2 Threaded outlet

If incorporated, a threaded outlet on plastics-bodied fittings shall be corrosion-free metallic male or female thread to ISO 7-1. Alternative threads and sizes may be acceptable to the user.

O.3.3 Specific sizes

The manufacturer’s range of plastics-bodied fittings should be suitable for the PE pipe sizes, tolerances and SDRs taken from GIS/PL2-2, as shown in Table O.2.

The nominal outside diameters are split into two size groups, 16 mm to 55 mm, and 63 mm to 180 mm.

Table O.1 – PE pipe sizes and SDRs

Nominal Outside Diameter d_n , mm	Mean Outside Diameter, mm		Wall Thickness, mm									
			SDR11		SDR13.6		SDR17.6		SDR21		SDR26	
	Min.	Max.	Min.	Max.	Min.	Max.	Min.	Max.	Min.	Max.	Min.	Max.
16 ^{a)}	16	16.3	2.3	2.7	-	-	-	-	-	-	-	-
20 ^{a)}	20	20.3	2.3	2.7	-	-	-	-	-	-	-	-
25	25	25.3	2.3	2.7	-	-	-	-	-	-	-	-
32	32	32.3	3.0	3.4	-	-	-	-	-	-	-	-
40	40	40.4	3.7	4.2	-	-	-	-	-	-	-	-
50	50	50.4	4.6	5.2	-	-	2.9	3.3	-	-	-	-
55	55	55.4	5.1	5.8	-	-	-	-	-	-	-	-
63	63	63.4	5.8	6.5	4.7	5.4	3.6	4.1	3.0	3.4	-	-
75	75	75.5	6.8	7.6	5.6	6.4	4.3	4.9	3.6	4.1	-	-
90	90	90.6	8.2	9.2	-	-	5.2	5.9	4.3	4.9	-	-
110	110	110.7	10.0	11.1	-	-	6.3	7.1	5.2	5.9	-	-
125	125	125.8	11.4	12.7	-	-	7.1	8.0	6.0	6.7	-	-
140	140	140.9	12.7	14.1	-	-	8.0	8.9	6.7	7.5	5.4	6.1
160	160	161.0	-	-	-	-	9.1	10.1	7.6	8.5	6.2	7.0
180	180	181.1	16.4	18.2	-	-	10.3	11.5	8.6	9.6	7.0	7.8

^{a)} For pipe sizes 16 mm and 20 mm, the actual values are SDR7 and SDR9 respectively due to minimum wall thickness considerations.

O.4 Additional or modified type test requirements for Class T fittings

O.4.1 Test pieces

The tests specified shall be carried out on fitting assemblies constructed by the fitting manufacturer or assembled by the user in accordance with manufacturer’s written instructions, including lubricants if required in the manufacturer’s instructions.

Class T fittings shall be assembled with polyethylene pipe conforming to GIS/PL2-2.

The use of an insert stiffener in the end of the PE pipe is not mandatory, but the joint shall meet the full tensile end load requirements in O.4.6

Test piece sample preparation temperatures and conditioning requirements are according to the parameters in each test. Each test shall be carried out immediately after conditioning, either inside

GIS/PL3:2023

or outside of an environmental chamber (where an environmental chamber is applicable).

O.4.2 Short-term hydrostatic pressure test at 20 °C

When a fitting assembly, assembled in accordance with Clause O.4.1, is tested as specified in BS EN 921, the assembly shall withstand minimum hold pressure given in Table O.3 at a temperature of 20 °C ± 2 °C for a period of 168 h without failure or leakage.

Half the fittings and pipe shall be conditioned for a minimum of 6 hours at 5 °C prior to assembly at this temperature. The test assembly shall then be further conditioned for a minimum of 4 hours at +20 °C prior to commencing the test procedure.

The remaining fittings and pipe shall be conditioned for a minimum of 6 hours at +30 °C prior to assembly at this temperature. The test assembly shall then be further conditioned for a minimum of 4 hours at +20 °C prior to commencing the test procedure.

Table O.3 — Short-term hydrostatic test pressures and time

Polyethylene pipe SDR	168 h hold pressure bar
	Class T
11	12.4
13.6	9.0
17.6	6.8
21	4.5
26	4.5

O.4.3 Leaktightness test

When a fitting assembly, assembled in accordance with Clause O.4.1, is leaktightness tested, it shall not leak.

Leaktightness testing shall be carried out in accordance with ISO 3458 with the exception that air or an inert gas shall be used as the pressurizing fluid instead of water.

Half the fittings and pipe shall be conditioned for a minimum of 6 hours at -5 °C prior to assembly at this temperature. The test assembly shall then be further conditioned for a minimum of 4 hours at -20 °C prior to commencing the test procedure at this temperature.

The remaining fittings and pipe shall be conditioned for a minimum of 6 hours at +30 °C prior to assembly at this temperature. The test assembly shall then be further conditioned for a minimum of 4 hours at +40 °C prior to commencing the test procedure at this temperature.

In the interests of safety, the volume of the assembly may be reduced using a filler rod or suitable solid material. Adequate precautions shall be taken to provide protection to personnel should the assembly fail under pressure.

Testing shall be carried out following the minimum test pressures and test times in Table O.4.

Table O.4 — Minimum test pressures and times for leaktightness tests

Pipe SDR	Test 1		Test 2 ^{b)}	
	Pressure ^{c)} mbar	Time h	Pressure bar	Time h
SDR11 ^{a)}	25	1	12.4	1
SDR13.6	25	1	9.0	1
SDR17.6	25	1	6.8	1
SDR21 and 26	25	1	4.5	1

- a) For pipe sizes 16 mm and 20 mm, the actual SDRs are SDR 7 and SDR 9 respectively due to minimum wall thickness requirements.
- b) Test 2 shall be conducted as soon as possible after test 1.
- c) If the fitting is submerged in water to detect leakage, then the 25mbar air test pressure shall be increased to compensate for the external water pressure, e.g. 250 mm water depth produces an external pressure of 25 mbar

O.4.4 Leaktightness with bending and temperature cycling

This test for temporary Class T fittings is NOT required.

O.4.5 Leaktightness with temperature cycling

When a fitting assembly, assembled in accordance with Clause O.4.1, is tested in accordance with the methodology outlined in Annex C, it shall not leak initially or at the end of the test.

However, for Class T fitting assemblies, the test shall be carried out with air at a test pressure of 8.3 bar for all fitting sizes and SDRs.

Half the fittings and pipe shall be conditioned for a minimum of 6 hours at -5 °C prior to assembly at this temperature. The test assembly shall then be further conditioned for a minimum of 4 hours at +10 °C prior to commencing the test procedure.

The remaining fittings and pipe shall be conditioned for a minimum of 6 hours at +30 °C prior to assembly at this temperature. The test assembly shall then be further conditioned for a minimum of 4 hours at +10 °C prior to commencing the test procedure.

O.4.6 Leaktightness after tensile testing

When a fitting assembly, assembled in accordance with Clause O.4.1, is tested in accordance with BS EN ISO 3501, the test force F_T is calculated, in Newtons, from Formula (1):

$$F_T = 1.5 \times \sigma_T \times \pi \times e_m \times (d_n - e_m) \times D_F \quad (1)$$

where

- σ_T is the applicable test stress given in Table O.5 (MPa);
- e_m is the mean wall thickness of the pipe (mm);
- d_n is the nominal outside diameter of the pipe (mm);
- D_F is the temperature derating coefficient given in Table O.6.

Table O.5 — Test stress depending on pipe material

Pipe material	Test stress (MPa)
PE80	5.7
PE100	6.6

Table O.6 — Temperature derating coefficient (D_F)

Test temperature	Derating coefficient (D_F)
-20 °C	1.0
40 °C	0.8

After the specified test duration, reduce the tensile force to zero and then pressurize the assembly with air to the appropriate STP, as shown in Table O.1 and check the leaktightness of the assembly for 1 h.

None of the following shall occur:

- a) damage or permanent deformation of the fitting assembly to an extent that would prevent conformity to this specification;

GIS/PL3:2023

- b) pull-out of the pipe;
- c) leakage during the leaktightness test that is conducted after the tensile test.

Half the fittings and pipe shall be conditioned for a minimum of 6 hours at -5 °C prior to assembly at this temperature. The test assembly shall then be further conditioned for a minimum of 4 hours at -20 °C prior to commencing the test procedure at this temperature.

The remaining fittings and pipe shall be conditioned for a minimum of 6 hours at +30 °C prior to assembly at this temperature. The test assembly shall then be further conditioned for a minimum of 4 hours at +40 °C prior to commencing the test procedure at this temperature.

It is permitted to replace the plastic-bodied coupler with a transition fitting of the same joint design, in order to conduct the tensile testing requirements on the PE pipe.

O.4.7 Gaseous flow / pressure drop relationship

The pressure drop across the fitting shall be kept to a minimum.

The minimum internal bore diameter, d_i , shall be stated by the manufacturer

The gaseous flow/pressure drop relationship is determined by measuring the air flow rate (m³/h) at ambient temperature (23 °C ± 2 °C) corresponding to a pressure drop across the fitting of 0.5 mbar and shall be declared by the manufacturer. The test method shall be in accordance with BS EN ISO 17778. Full details of the test results shall be made available in a report.

O.4.8 Impact strength

When a fitting assembly, assembled in accordance with Clause O.4.1, is tested in accordance with Annex H (but with the following exceptions), it shall not leak:

- the fittings and pipe shall be conditioned for a minimum of 6 hours at 5 °C prior to assembly at this temperature. The test assembly shall then be further conditioned for a minimum of 4 hours at -20 °C prior to commencing the test procedure at this temperature.
- the striker head radius shall be 50 mm, as shown in Figure O.1.

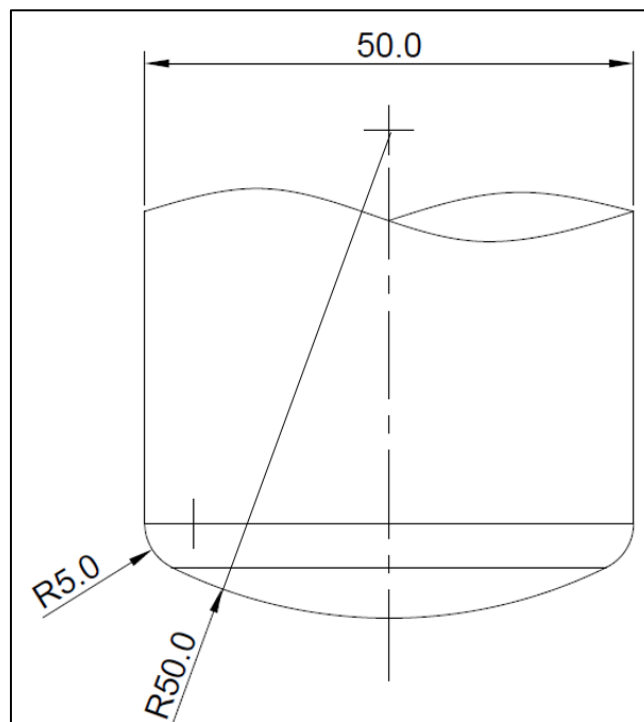

Figure O.1 Impact Striker Head

O.4.9 Leaktightness during and after rotation (Elbows only)

When a fitting assembly, assembled in accordance with Clause O.4.1, is subjected to rotation about the pipe axis, it shall not leak.

If the elbow outlet incorporates a swivel joint with the body of the fitting, then the torque should be applied to the elbow outlet of the swivel joint not the fitting body.

Half the fittings and pipe shall be conditioned for a minimum of 6 hours at -5 °C prior to assembly at this temperature. The test assembly shall then be further conditioned for a minimum of 4 hours at -20 °C prior to commencing the test procedure at this temperature.

The remaining fittings and pipe shall be conditioned for a minimum of 6 hours at +30 °C prior to assembly at this temperature. The test assembly shall then be further conditioned for a minimum of 4 hours at +40 °C prior to commencing the test procedure at this temperature.

Following the manufacturer's instructions, the plastics-bodied, reusable fitting shall be assembled onto a polyethylene pipe of length of which is a minimum 10 times the pipe's diameter. A steel pipe of appropriate diameter and length of approximately 2 m shall be screwed into the elbow outlet.

The other end of the polyethylene pipe shall be restrained over a minimum length of one pipe diameter.

The steel pipe shall be aligned vertically.

Pressurise the pipe with air to the appropriate STP, as shown in Table O.1. Monitor any leakage for a period of 30 minutes.

Over a maximum of 3 seconds, the vertical steel pipe shall be rotated by 30° in a clockwise direction, hold for 5 seconds.

Return the steel pipe to its starting position.

Over a maximum of 3 seconds, the vertical steel pipe shall be rotated by 30° in a counter clockwise direction, hold for 5 seconds.

Return the pipe to the original 0° of rotation. Monitor any leakage for a period of 30 minutes.

O.4.10 Leaktightness during and after axial bending (Elbows only)

When a fitting assembly, assembled in accordance with Clause O.4.1, is subjected to a bending moment along the pipe axis, it shall not leak.

Half the fittings and pipe shall be conditioned for a minimum of 6 hours at -5 °C prior to assembly at this temperature. The test assembly shall then be further conditioned for a minimum of 4 hours at -20 °C prior to commencing the test procedure at this temperature.

The remaining fittings and pipe shall be conditioned for a minimum of 6 hours at +30 °C prior to assembly at this temperature. The test assembly shall then be further conditioned for a minimum of 4 hours at +40 °C prior to commencing the test procedure at this temperature.

Following the manufacturer's instructions, the plastics-bodied, reusable fitting shall be assembled onto a polyethylene pipe the length of which is 10 times the pipe's diameter. A steel pipe of appropriate diameter and length of approximately 2m shall be screwed into the elbow outlet.

The other end of the polyethylene pipe shall be restrained over a length of one pipe diameter.

Pressurise the pipe with air to the appropriate STP, as shown in Table O.1. Monitor any leakage for a period of 30 minutes.

Over a maximum of 3 seconds, the vertical steel pipe shall be deflected axially by 15° along the centre line of the polyethylene pipe to which it is assembled, hold for 5 seconds.

Return the steel pipe to its starting position.

Over a maximum of 3 seconds, the vertical steel pipe shall be deflected axially by 15° in the opposite direction along the centre line of the polyethylene pipe to which it is assembled, hold for 5 seconds.

GIS/PL3:2023

Hold at the starting position and monitor for any leakage for a period of 30 minutes.

O.4.11 Leaktightness after multiple reuse (50 times)

When a single fitting is assembled 50 times, in accordance with Clause O.4.1, it shall not leak.

Half the fittings and pipe shall be conditioned for a minimum of 6 hours at -5 °C prior to assembly at this temperature. The test assembly shall then be further conditioned for a minimum of 4 hours at -20 °C prior to commencing the test procedure at this temperature.

The remaining fittings and pipe shall be conditioned for a minimum of 6 hours at +30 °C prior to assembly at this temperature. The test assembly shall then be further conditioned for a minimum of 4 hours at +40 °C prior to commencing the test procedure at this temperature.

Assemble the fitting on the PE pipe according to the manufacturer's instructions and then remove it. Clean the fitting and, if necessary, re-apply any approved lubricant recommended by the manufacturer. Following inspection after each use, if required, the seals may be replaced. Repeat the assembly and removal 50 times, each time on a new piece of PE pipe.

The assembly shall remain leak tight in accordance with O.4.3.

O.4.12 Sturdiness of metallic female threads

The socket on the fitting shall show no signs of damage or cracking after being mounted on a plug gauge as described in Annex J. The assembly shall remain leak tight in accordance with O.4.3.

Half the fittings and pipe shall be conditioned for a minimum of 6 hours at -5 °C prior to assembly at this temperature. The test assembly shall then be further conditioned for a minimum of 4 hours at -20 °C prior to commencing the test procedure at this temperature.

The remaining fittings and pipe shall be conditioned for a minimum of 6 hours at +30 °C prior to assembly at this temperature. The test assembly shall then be further conditioned for a minimum of 4 hours at +40 °C prior to commencing the test procedure at this temperature.

O.4.13 Purge flow rate (Purge fittings only)

When a flow is applied through a fitting assembly, assembled in accordance with Clause O.4.1, the flow rate and flow velocity shall be greater than those detailed in Table O.7.

The purge flow rate is determined by measuring the air flow rate (m³/h) at ambient temperature (23 °C ± 2 °C) with an inlet pressure of 21 mbar.

Table O.7 —Minimum flow rate requirements for fittings used for purging

Inlet Pressure mbar	Minimum Flow Rate m ³ /min	Minimum Purge Velocity m/s
21.0	0.7	0.6

The test method shall be in accordance with BS EN ISO 17778. Full details of the test results shall be made available in a report.

O.5 Fitness for purpose

O.5.1 General

All fittings shall undergo the appropriate type approval tests defined in Table O.9, Table O.10, and Table O.11.

Assembly of the plastics-bodied purge elbows is NOT required on the maximum and minimum tolerance PE pipe diameters.

O.5.2 Sample grouping for Class T fittings

The sample test grouping shall be based upon the diameter size group and pipe SDR (see Table O.8). The manufacturer shall choose size group and an SDR for the fitting range. The maximum, minimum, and one intermediate fitting size of this range shall be tested.

Table O.8 — Sample size grouping

Diameter Size Group	Pipe Diameter Range, mm	Applicable SDRs				
		11	13.6	17.6	21	26
1	16 – 55	✓	N/A	✓	N/A	N/A
2	63 – 180	✓	✓	✓	✓	✓

Approval of the three fitting sizes would give approval to all intermediate fitting sizes, provided other sizes are of the same design.

O.6 Batch release testing

Batch release testing shall be as in Clause 11 (Table 9) with the exception of the Hydrostatic test at 80 °C, for 1 000 h which is replaced by the short-term hydrostatic strength test in Clause O.4.2 for all sizes.

Table O.9 – Properties of temporary, re-usable plastics-bodied end caps (Class T) that require type testing

Property		Shall conform to	Sampling procedure ^a	Number of test pieces ^b	Number of measurements per test piece
Appearance		7.1	All sizes	1	1
Colour		7.7.1 ^d	All sizes	1	1
Mechanical properties	Short-term hydrostatic pressure test at 20 °C (168 h)	O.4.2	All sizes	6 ^c	1
	Leaktightness test	O.4.3	All sizes	6 ^c	1
	Leaktightness with temperature cycling	O.4.5 Annex C	Three diameters / test group	6 ^c	1
	Leaktightness after tensile testing	O.4.6 Annex D	Three diameters / test group	6 ^c	1
	Impact strength	O.4.8 Annex H	Three diameters / test group	6 ^c	1
	Re-usability (50x) - Leaktightness	O.4.11	Three diameters / test group	6 ^c	1
Marking		12	All sizes	1	1

^{a)} The product range in each size group shall be defined by the manufacturer. Samples shall comprise the smallest, largest and one intermediate diameter of the range manufactured. The sample test grouping is described in O.5.2. Where a manufacturer extends production beyond approval, additional relevant type testing shall be carried out.

^{b)} The number of test pieces given in the table is the minimum for each diameter per test group. All test pieces shall pass the relevant test(s).

^{c)} Tests are undertaken at both maximum and minimum test temperatures per fitting size, with three repeats.

^{d)} Other colours may be permitted for temporary, re-usable plastics-bodied fittings

Table O.10 – Properties of temporary, re-usable plastics-bodied couplings (Class T) that require type testing

Property	Shall conform to	Sampling procedure ^a	Number of test pieces ^b	Number of measurements per test piece	
Appearance	7.1	All sizes	1	1	
Colour	7.7.1 ^d	All sizes	1	1	
Mechanical properties	Short-term hydrostatic pressure test at 20 °C (168 h)	O.4.2	All sizes	6 ^c	1
	Leaktightness test	O.4.3	All sizes	6 ^c	1
	Leaktightness with temperature cycling	O.4.5 Annex C	Three diameters / test group	6 ^c	1
	Leaktightness after tensile testing	O.4.6 Annex D	Three diameters / test group	6 ^c	1
	Gaseous flow / pressure drop	O.4.7	Three diameters / test group	1	1
	Impact strength	O.4.8 Annex H	Three diameters / test group	6 ^c	1
	Leaktightness during and after rotation (Elbows only)	O.4.9	Three diameters / test group	6 ^c	1
	Leaktightness during and after axial bending (Elbows Only)	O.4.10	Three diameters / test group	6 ^c	1
	Re-usability (50x) - Leaktightness	O.4.11	Three diameters / test group	6 ^c	1
	Purge flow rate (purge fittings only)	O.4.13	Three diameters / test group	1	1
Marking	12	All sizes	1	1	

^{a)} The product range in each size group shall be defined by the manufacturer. Samples shall comprise the smallest, largest and one intermediate diameter of the range manufactured. The sample test grouping is described in O.5.2. Where a manufacturer extends production beyond approval, additional relevant type testing shall be carried out.

^{b)} The number of test pieces given in the table is the minimum for each diameter per test group. All test pieces shall pass the relevant test(s).

^{c)} Tests are undertaken at both maximum and minimum test temperatures per fitting size, with three repeats.

^{d)} Other colours may be permitted for temporary, re-usable plastics-bodied fittings

GIS/PL3:2023

Table O.11 – Properties of temporary, re-usable plastics-bodied transition fittings (Class T) that require type testing

Property		Shall conform to	Sampling procedure ^a	Number of test pieces ^b	Number of measurements per test piece
Appearance		7.1	All sizes	1	1
Colour		7.7.1 ^d	All sizes	1	1
Mechanical properties	Short-term hydrostatic pressure test at 20 °C (168 h)	O.4.2	All sizes	6 ^c	1
	Leaktightness test	O.4.3	All sizes	6 ^c	1
	Leaktightness with temperature cycling	O.4.5 Annex C	Three diameters / test group	6 ^c	1
	Leaktightness after tensile testing	O.4.6 Annex D	Three diameters / test group	6 ^c	1
	Gaseous flow / pressure drop	O.4.7	Three diameters / test group	1	1
	Impact strength	O.4.8 Annex H	Three diameters / test group	6 ^c	1
	Leaktightness during and after rotation (Elbows only)	O.4.9	Three diameters / test group	6 ^c	1
	Leaktightness during and after axial bending (Elbows Only)	O..10	Three diameters / test group	6 ^c	1
	Re-usability (50x) - Leaktightness	O.4.11	Three diameters / test group	6 ^c	1
	Sturdiness of metallic female threads	O.4.12 Annex J	Three diameters / test group	6 ^c	
	Purge flow rate (purge fittings only)	O.4.13	Three diameters / test group	1	1
Marking		12	All sizes	1	1

^{a)} The product range in each size group shall be defined by the manufacturer. Samples shall comprise the smallest, largest and one intermediate diameter of the range manufactured. The sample test grouping is described in O.5.2. Where a manufacturer extends production beyond approval, additional relevant type testing shall be carried out.

^{b)} The number of test pieces given in the table is the minimum for each diameter per test group. All test pieces shall pass the relevant test(s).

^{c)} Tests are undertaken at both maximum and minimum test temperatures per fitting size, with three repeats.

^{d)} Other colours may be permitted for temporary, re-usable plastics-bodied fittings