

**Gas Utilization Procedures**  
**IGE/UP/7 Edition 2 (with Amendments October 2008)**  
**Communication 1722**

**Gas installations in timber framed and light steel framed buildings**

*This Publication has been made available by IGEM through Gas Safe Register under the "Access to Standards" initiative.*

*The Publication is intended for the sole use of those companies who have subscribed to the "Access to Standards" initiative.*

*All content in this publication is, unless stated otherwise, the property of IGEM. Copyright laws protect this publication. Reproduction or re-transmission in whole or in part, in any manner, without the prior written consent of the copyright holder, is a violation of copyright law.*



Founded 1863  
Royal Charter 1929  
Patron: Her Majesty the Queen



**Gas Utilization Procedures**  
**IGE/UP/7 Edition 2 (with Amendments October 2008)**  
**Communication 1722**

**Gas installations in timber framed and light steel  
framed buildings**

Price Code: T5  
© The Institution of Gas Engineers and Managers  
Charnwood Wing  
Holywell Park  
Ashby Road  
Loughborough, Leics, LE11 3GH  
Tel: 01509 282728  
Fax: 01509 283110  
Email: [general@igem.org.uk](mailto:general@igem.org.uk)  
Published: August 2006



# CONTENTS

SECTION		PAGE
1	Introduction	1
2	Scope	3
3	Legal and allied considerations	5
	• 3.1 General	5
	• 3.2 Legislation	5
	• 3.2.1 Health and Safety at Work etc. Act (HSWA)	5
	• 3.2.2 Management of Health and Safety at Work Regulations (MHSWR)	5
	• 3.2.3 Gas Safety (Installation and Use) Regulations (GS(I&U)R)	5
	• 3.2.4 The Gas Safety (Management) Regulations (GS(M)R)	6
	• 3.2.5 Pipeline Safety Regulations (PSR)	6
	• 3.2.6 The Gas Appliances (Safety) Regulations	6
	• 3.2.7 Electrical Regulations	6
	• 3.2.8 Construction (Design and Management) Regulations (CDM)	7
	• 3.2.9 Building Regulations	7
	• 3.2.10 Dangerous Substances and Explosive Atmospheres Regulations (DSEAR)	8
	• 3.2.11 Construction (Health, Safety and Welfare) Regulations (CHSWR)	8
	• 3.3 Allied considerations	9
	• 3.3.1 Compliance	9
	• 3.3.2 Responsibilities	9
	<b>PART 1 - TIMBER FRAMED BUILDINGS</b>	10
4	Network pipelines	10
5	Meter installations	11
	• 5.1 General	11
	• 5.2 Routes for installation pipework from external meter positions	11
	• 5.2.1 From a built-in meter box	11
	• 5.2.2 From a surface mounted meter box	14
	• 5.2.3 From a semi-concealed meter box	14
6	Installation pipework	15
	• 6.1 General	15
	• 6.2 Pipework in or under floors	16
	• 6.2.1 Concrete floors	16
	• 6.2.2 Timber floors	16
	• 6.3 Pipework in or through walls	17
7	Appliances	19
	• 7.1 General	19
	• 7.2 Combustible wall surfaces	19
	• 7.3 Support of appliances	19
	• 7.3.1 General	19
	• 7.3.2 Existing buildings	20
	• 7.3.3 New buildings	20

• 7.4	Vapour control layer (VCL)	23
• 7.5	Provision of air	23
• 7.6	Installation of a room sealed appliance, for example a boiler	24
• 7.6.1	General	24
• 7.6.2	VCL	25
• 7.6.3	Installation anticipated at building design or construction stage	25
• 7.6.4	Installation after the building has been constructed	26
• 7.6.5	Removal of an existing appliance	29
8	Chimneys	31
• 8.1	Preliminary considerations	31
• 8.2	Chimney terminology	31
• 8.2.1	Definitions	31
• 8.2.2	Chimney designations	32
• 8.3	Design of open flue chimneys	37
• 8.3.1	General	37
• 8.3.2	Flue block systems	37
• 8.3.3	Metallic chimneys	38
• 8.3.4	Masonry chimneys	39
• 8.3.5	Chimneys for gas fires	39
• 8.4	Installation of chimneys	39
• 8.4.1	General	39
• 8.4.2	Flue block systems	40
• 8.4.3	Metal chimneys	40
• 8.4.4	The timber structure	40
	<b>PART 2 - LIGHT STEEL FRAMED BUILDINGS</b>	41
9	Network pipelines and service pipework	41
10	Meter installations	41
11	Installation pipework	41
12	Appliances	41
	<b>APPENDIX</b>	
1	Glossary, acronyms, abbreviations, symbols and units	43
2	References	47
3	Timber frame construction	50
4	Light steel frame construction	58
5	Supporting an appliance in an existing timber framed building	61
6	A typical method of accommodating movement for pipework passing through a timber frame/masonry wall	64
	<b>FIGURE</b>	
1	Network pipeline entry for internal meters in a block of flats	10
2	Pipework route via the rear spigot of a meter box	12

3	Pipework route – external	13
4	Pipework route (semi-concealed meter box)	14
5	Pipework in a timber leaf	18
6	Fitting a wall mounted room sealed appliance on an existing timber frame external wall	21
7	Fitting a wall mounted room sealed appliance on a purpose designed frame	22
8	Installation of a vent	24
9	Installation of a room sealed chimney system terminal	27
10	Moisture transport preventors	28
11	Installation of a room sealed chimney system terminal (circular) through an existing timber frame	29
12	Proprietary metal system chimney	33
13	Proprietary pre-cast concrete system chimney	34
14	Section through proprietary pre-cast concrete block chimney in timber framed external wall	35
15	Typical internal masonry chimney	35
16	External fireplace recess and masonry chimney	36
17	Typical timber frame construction using the platform frame method	51
18	Typical constructional details	52
19	Typical shrinkage based on TF 2000 formula	55
20	Allowable size and location of notches and holes in solid timber joists	56
21	Allowable size and location of holes in wall studding	57
22	Steel frames. C sectioned steel studs with flat diagonal strapping on outer surface	59
23	Steel frames assembled together	59
24	“I” joists with swaged holes to accommodate non-gas services	60
25	Lattice webbed “I” joists	60
26	Acceptable and not acceptable applications of typical metallic cavity fixings	63
27	A schematic arrangement for accommodating movement for pipework passing through a timber frame/masonry wall	64
 <b>TABLE</b>		
1	Responsibilities for installation	9

## SECTION 1 : INTRODUCTION

- 1.1 These Procedures have been drafted by an Institution of Gas Engineers and Managers' (IGEM) Panel, appointed by IGEM's Gas Utilization Committee, and have been approved by IGEM's Technical Co-Ordinating Committee on behalf of the Council of IGEM.

The Panel comprised representatives of:

- Association of Independent Gas Transporters (AIGT)
- British Flue and Chimney Manufacturers Association (BFCMA)
- British Gas plc
- Council for Registered Gas Installers (CORGI)
- Home Builders Federation (HBF)
- Health and Safety Executive (HSE)
- Institution of Gas Engineers and Managers (IGEM)
- National Grid plc
- National House Building Council (NHBC)
- SBGI (formerly known as the Society of British Gas Industries)
- Scottish Building Standards Agency (SBSA)
- Steel Construction Institute
- United Kingdom Timber Frame Association (UKTFA).

- 1.2 These Procedures supersede IGE/UP/7, Communication 1651, which is obsolete.

These Utilization Procedures were published on 5<sup>th</sup> September 2006. They may be used rather than the procedures given in IGE/UP/7 Edition 1 immediately, but a lead-in period is allowed permitting the use of Edition 1 until 5<sup>th</sup> December 2006.

- 1.3 These Procedures offer guidance on fixed gas installations within timber and light steel framed buildings and are directed at architects, designers, builders, building control, gas transporters (GTs), utility infrastructure providers (UIPs), gas operatives and appliance and component manufacturers.

The intent is to provide a source of information on good practice for gas installations in timber and light steel framed buildings with explanatory reference to the special features of construction that affect such installations.

These Procedures are additional to otherwise available general practices, manufacturer's instructions and guidance appertaining to gas installations.

- 1.4 Although the most common types of construction and installation are covered, the Procedures cannot be comprehensive as there are variants in timber and light steel frame construction such as the type of external cladding and lining used. In addition, appliance design and installation are under continual development and, thus, this document can present a view of the situation only at the time of writing.

- 1.5 New terms such as "maximum operating pressure" (MOP) and "operating pressure" (OP) have been introduced to reflect gas pressure terminology used in European standards. These terms will arise in all relevant IGEM technical publications in future and, possibly, in other standards. Other new terms have been introduced to assist in recognition of design information to be transferred between interested parties.

New European terminology in relation to chimneys has also been incorporated.

- 1.6 These Procedures make use of the terms "should", "shall" and "must" when prescribing particular procedures. Notwithstanding Sub-Section 1.9:
- (a) The term "must" identifies a requirement by law in Great Britain at the time of publication.
  - (b) The term "shall" prescribes a procedure which, it is intended, will be complied with in full and without deviation.
  - (c) The term "should" prescribes a procedure which, it is intended, will be complied with unless, after prior consideration, deviation is considered to be acceptable.
- 1.7 The primary responsibility for compliance with legal duties rests with the employer. The fact that certain employees, for example "responsible engineers", are allowed to exercise their professional judgement does not allow employers to abrogate their primary responsibilities. Employers must:
- comply with legislation
  - have done everything to ensure, so far as is reasonably practicable, that there are no better protective measures that can be taken other than relying on the exercise of professional judgement by "responsible engineers".
  - have done everything to ensure, so far as is reasonably practicable, that "responsible engineers" have the skills, training, experience and personal qualities necessary for the proper exercise of professional judgement.
  - have systems and procedures in place to ensure that the exercise of professional judgement by "responsible engineers" is subject to appropriate monitoring and review.
  - not require "responsible engineers" to undertake tasks which would necessitate the exercise of professional judgement that is outwith their competence. There should be written procedures defining the extent to which "responsible engineers" can exercise their judgement. When "responsible engineers" are asked to undertake tasks which deviate from this, they should refer the matter for higher review.
- 1.8 It is now widely accepted that the majority of accidents in industry generally are in some measure attributable to human as well as technical factors in the sense that actions by people initiated or contributed to the accidents, or people might have acted better to avert them.
- It is, therefore, necessary to give proper consideration to the management of these human factors and the control of risk. To assist in this, it is recommended that due cognizance be taken of the HS(G)48.
- 1.9 These Procedures do not attempt to make the use of any method or specification obligatory against the judgement of the responsible engineer. Where new and better techniques are developed and proved, they should be adopted without waiting for modification to these Procedures. Amendments to these Procedures will be issued when necessary and their publication will be announced in the Journal of IGEM and other publications as appropriate.
- 1.10 Requests for interpretation of these Procedures in relation to matters within their scope, but not precisely covered by the current text, should be addressed to Technical Services, IGEM, Charnwood Wing, Holywell Park, Ashford Road, Loughborough, Leicestershire, LE11 3GH and will be submitted to the relevant Committee for consideration and advice, but in the context that the final responsibility is that of the engineer concerned. If any advice is given by or on behalf of IGEM, this does not relieve the responsible engineer of any of his or her obligations.

## SECTION 2 : SCOPE

- 2.1 These Procedures apply to the installation of Network pipelines (see Note below), meter installations, installation pipes and pipework and appliances including their open flue chimney or room sealed chimney system, in new and existing timber and light steel framed buildings containing single or multiple dwellings (for example flats and maisonettes). The principles contained in these Procedures may also be applied to some non-domestic buildings but these Procedures do not address such special applications directly.

*Note: Network pipelines, for the purposes of these Procedures, include "distribution mains", "service pipes" and, for LPG "service pipework". While there may be differences between these terms within relevant legislation, for "distribution mains" and "service pipes" for Natural Gas the technical advice contained in these Procedures is the same. For "service pipework" for LPG, the advice again is the same but due allowance has to be taken of the properties of LPG compared to Natural Gas.*

*IGE/G/1 contains further information with respect to Natural Gas pipelines.*

As timber framed and light steel framed buildings are, essentially, similar in principle, most of the procedures are addressed to timber framed buildings (Part 1) and the points of difference applied to light steel framed buildings are given in Part 2. General descriptions of both types of construction are given in the appendices.

- 2.2 Part 1 of these Procedures deals specifically with timber framed buildings constructed by the platform frame method (see Appendix 3) although, in general, it is appropriate to other types of timber frame construction.

*Note 1: The details for installations in multi-dwelling buildings are referred to IGE/G/5, except where there are specific procedures concerning the timber or light steel frame construction.*

*Note 2 These Procedures assume a gas supply layout as given in IGE/G/1 for "recommended gas supply arrangements".*

- 2.3 These Procedures cover installations utilizing odourised 2nd family gas, for example Natural Gas at a maximum operating pressure (MOP) of 75 mbar within buildings and 3rd family gas, for example LPG. While these comprise the majority of fuel gases available, the Procedures will, on the whole, be applicable for other fuel gases although cognizance has to be taken of special properties of such gases both in the burned and unburned state.

*Note: This limits MOP downstream of the meter regulator to 75 mbar. Where the Network MOP exceeds 75 mbar, a pressure regulating installation (PRI) has to be installed in the Network pipeline in accordance with IGE/TD/13 or a primary meter installation has to be installed in accordance with IGE/GM/8 or BS 6400-2, as appropriate. Such an installation has to be located outside the building or in a separate enclosure sealed from the building and accessible only from outside.*

- 2.4 These Procedures are applicable to the installation of appliances having a heat input not exceeding 70 kW based on net calorific value (CV), which have been CE marked and for which the appliance manufacturer's instructions advise that the appliance is suitable for installation in a timber frame and/or a light steel frame building.

*Note: For countries outside the European Union, the Procedures will be applicable provided that the appliance concerned complies with standards equivalent to those applied for CE marking.*

- 2.5 These Procedures apply to all types of open flue chimney or room sealed chimney system (that comply with appropriate construction standards) for gas appliances, whether they are separate from, or integral with, the appliances.

- 2.6 These Procedures apply to first time installations and to renewals/renovations (retrofits).



- 2.7 The illustrations in these Procedures are intended to support the stated procedures for the purpose of clarity. They should not be considered as necessarily showing the only method of complying with the Procedures. However, they are intended to depict good practice.
- 2.8 Italicised text is informative and does not represent formal Procedures.
- 2.9 Appendices are informative and do not represent formal Procedures unless specifically referenced in the main sections via the prescriptive terms “should”, “shall” or “must”.

## SECTION 3 : LEGAL AND ALLIED CONSIDERATIONS

### 3.1 GENERAL

These Procedures are set out against a background of legislation in force in Great Britain at the time of publication. Similar considerations are likely to apply in other countries and reference to the appropriate national legislation will be necessary. The legal and allied considerations outlined in this section are, particularly, relevant to gas installations in framed buildings.

Appendix 2 lists legislation, guidance notes, Standards etc., which are identified within these Procedures, as well as further publications that may be applicable. Where standards etc. are quoted, equivalent national or international Standards etc. equally may be appropriate. Unless otherwise stated, the latest version of the referenced document should be used.

*Note: A more comprehensive summary of many of the following items of legislation is given in HS(L)56.*

Of particular note in this respect are the European Standards that are coming into being and which, in some cases, cause the equivalent British Standards to be withdrawn. It should be noted that, in this context, "equivalent" means equivalent not only in scope but also in technical requirement.

### 3.2 LEGISLATION

#### 3.2.1 Health and Safety at Work etc. Act (HSWA)

HSWA applies to all persons involved with work activities, including employers, the self-employed, employees, designers, manufacturers, suppliers, etc. as well as the owners of premises. It places general duties on such people to ensure, so far as is reasonably practicable, the health, safety and welfare of employees and the health and safety of members of the public who may be affected by the work activity.

#### 3.2.2 Management of Health and Safety at Work Regulations (MHSWR)

MHSWR are linked closely with specific duties under GS(I&U)R (see clause 3.2.3) and impose a duty on employers and the self-employed to make assessments of risks to the health and safety of employees, and non-employees affected by their work. They also require effective planning and review of protective measures.

#### 3.2.3 Gas Safety (Installation and Use) Regulations (GS(I&U)R)

GS(I&U)R are relevant statutory provisions of HSWA, setting out general and detailed requirements dealing with the safe installation, maintenance and use of gas systems (including gas fittings (including meters), appliances and flues (chimneys)).

GS(I&U)R place responsibilities on those installing, servicing, maintaining or repairing gas appliances, pipework, meters, etc. as well as on suppliers and users of gas.

GS(I&U)R define the type of work that requires persons carrying out such work, or their employers, to be a "member of a class of persons", for example registered with the Council for Registered Gas Installers (CORGI).

*Note: Guidance on the individual competency required for persons carrying out work at premises not covered by GS(I&U)R is given in the HSC COP 20.*

Persons deemed competent to carry out gas work are those who hold a current certificate of gas safety competence acceptable to CORGI which includes (without limitation) the Accredited Certification Scheme (ACS) and/or the Gas Services S/NVQ that has been aligned to ACS.

The installer must check the safety of any appliance or pipework they install or work on and take appropriate action where they find faults. Where the premises are let or hired out, the landlord/hirer has special responsibilities to ensure that any installer they use for gas fitting, service, maintenance or safety is an approved class of person if applicable (see Sub-Section 3.3) and is competent to carry out such work. If any serious fault is found, the installer must inform both the landlord/hirer, as well as the user, so that such faults can be rectified before further use. Reference should also be made to the current "Gas Industry Unsafe Situations Procedure".

*Note: HS(L)56 is an ACoP and guidance on the Regulations.*

### 3.2.4 **The Gas Safety (Management) Regulations (GS(M)R)**

These Regulations generally apply to the network, including service pipes upstream of the emergency control valve (ECV). They require gas transporters (GTs) to have an approved safety case for their Natural Gas network. Such safety cases contain details of the technical specifications used within the network.

*Note: HS(L)80 gives guidance on the Regulations.*

### 3.2.5 **Pipeline Safety Regulations (PSR)**

These Regulations place a duty on the operator (gas transporter) of pipelines, including service pipes and service pipelines, as identified in Section 4. Operators must ensure that such pipes are designed, constructed and installed so that, as far as is reasonable practicable, they are sound and fit for purpose.

*Note: HS(L)82 gives guidance on the Regulations.*

### 3.2.6 **The Gas Appliances (Safety) Regulations**

These Regulations specify that all gas appliances must meet a set of requirements before being sold. The main provisions are that appliances must:

- be safe – comply with the essential requirements. British/European standards may give details of how to comply
- be tested – by an independent notified body
- be quality guaranteed – manufacturer's quality scheme for production appliances monitored by notified body
- carry a CE mark – issued under the authority of a notified body.

### 3.2.7 **Electrical Regulations**

Electrical regulations apply to timber and light steel framed buildings, as with other types of buildings. Organizations that operate approved competent person self-certification schemes at the time of publication of IGE/UP/7 are: BRE, BSI, ELECSA, NAPIT, NICEIC, CORGI and OFTEC.

#### 3.2.7.1 **Electricity at Work Regulations**

These Regulations apply to a wide range of electrical work, from overhead power lines to the use of office computers and batteries and include work on gas equipment using electrical energy.

The Regulations are concerned with the prevention of danger from electric shock, electric burn, electrical explosion or arcing or from fire or explosion initiated by electrical energy.

The Regulations impose duties on every employer, employee and self-employed person and require that persons engaged in electrical work be competent or be supervised by competent persons.

*Note: HS(R)25 gives guidance on the Regulations.*

### 3.2.7.2 **Part P of the Building Regulations (see also clause 3.2.9)**

This relatively new approved document (for England and Wales) relies heavily on established supporting guidance in the following documents:

- BS 7671
- IEE Guidance Notes
- The IEE publication: Electrician's Guide to the Building Regulations.

### 3.2.8 **Construction (Design and Management) Regulations (CDM)**

These Regulations place duties on clients, designers, contractors and planning supervisors to ensure that health and safety is taken into account and managed effectively throughout all stages of a construction project. They apply to most building projects and include provisions for the installation, commissioning, maintenance, repair and removal of gas services fixed within, and supplying, a building. The duty holder has to ensure that safe and adequate access is provided to the gas services to carry out such activities.

### 3.2.9 **Building Regulations**

Although many of the requirements of the Building Regulations England and Wales and the Building (Scotland) Regulations are similar, they sometimes differ in specific detail. The designer should refer to the appropriate Regulations for the country concerned.

#### 3.2.9.1 **Building Regulations England and Wales (As Amended)**

Building Regulations are statutory instruments that must be followed when engaged in any building work. They are written in a format of broad Regulations, setting out requirements in a separate Schedule. Suggested ways of complying with these Regulations are contained in Approved Documents (ADs).

The ADs are:

- A - Structure
- B - Fire safety
- C - Site preparation and resistance to moisture
- D - Toxic substances
- E - Resistance to the passage of sound
- F - Ventilation
- G - Hygiene (G3 - Hot water storage)
- H - Drainage and waste disposal
- J - Combustion appliances and fuel storage systems
- K - Protection from falling, collision and impact
- L - Conservation of fuel and power
- M - Access to and use of buildings
- N - Glazing

- P - Electrical safety.

The Building Regulations and ADs are available on [www.planningportal.gov.uk](http://www.planningportal.gov.uk) or in hard copy from The Stationery Office (TSE) and other booksellers.

### 3.2.9.2 ***Building (Scotland) Regulations***

The Building (Scotland) Regulations are written directly as Regulations within the statutory instrument.

One method of complying with the Regulations is by following the guidance contained in the Technical Handbooks which have been issued by Scottish Ministers through the Scottish Building Standards Agency.

There are two Technical Handbooks, one for domestic buildings and the other for non-domestic buildings. The Handbooks are sub-divided into the following sections which could apply to any gas work:

- Section 1 - Structure
- Section 2 - Fire
- Section 3 - Environment
- Section 4 - Safety
- Section 5 - Noise
- Section 6 - Energy.

The Technical Handbooks are available on the Agency website, [www.sbsa.gov.uk](http://www.sbsa.gov.uk) or in hard copy from booksellers.

### 3.2.9.3 ***Building Regulations (Northern Ireland)***

These are presented in a similar format of regulations with supporting Approved Documents to England and Wales, albeit with a different layout.

### 3.2.9.4 ***Building Regulations for the Isle of Man***

These are Isle of Man Government statutory regulations.

### 3.2.10 **Dangerous Substances and Explosive Atmospheres Regulations (DSEAR)**

DSEAR apply to any workplace where there is present any substance or mixture of substances with the potential to create a risk from energetic (energy-releasing) events such as fire, explosions, etc. Such substances, known in DSEAR as dangerous substances, include Natural Gas and LPG. Installation of appliances manufactured to the Gas Appliances (Safety) Regulations is excluded from DSEAR, as is a "gas fitting", within the meaning of GS(I&U)R, at domestic premises. However, service pipes and service pipework are not such gas fittings and any work carried out in domestic premises, when service pipes or service pipework contain gas, is subject to DSEAR.

DSEAR require pipes to be labelled, for example to indicate they contain gas.

### 3.2.11 **Construction (Health, Safety and Welfare) Regulations (CHSWR)**

CHSWR are intended to fulfil the requirements of a European Directive that are not fulfilled by CDM. They apply to any place where the principal work activity being carried out is construction work, for example alteration, renovation, repair or maintenance of a gas pipe or pipeline. They are concerned with ensuring a safe place of work for any person while at work and the health and safety of any person affected by a person at work.

3.3 **ALLIED CONSIDERATIONS**

3.3.1 **Compliance**

The installation of a gas meter installation, pipework, appliance, chimney or a room sealed chimney system in the following hierarchy of precedence must comply with any relevant statutory instrument and the following provide detail of ways of complying:

- ADs or Technical Handbooks to Building Regulations
- HS(L)56
- instructions provided by the appliance or chimney manufacturer
- British or European Standards or IGEM Procedures, Guidance and Recommendations.

3.3.2 **Responsibilities**

Responsibilities for installation are shown in Table 1.

DESCRIPTION	RESPONSIBILITY
Network pipeline including the emergency control valve (ECV)	GT
Primary meter installation	Meter owner (occupier, landlord/housing association, meter asset manager (MAM)) <i>Note: The GT has responsibility for pressure control in all cases, and others have to request permission from the GT to break the seal on the meter regulator to make pressure adjustments.</i>
Installation pipework (including secondary meters)	Pipework owner (occupier, landlord/housing association)
Appliance connector and appliance	Appliance owner (occupier, landlord/housing association)

*Note 1: An emergency control is defined by Regulation 2 of GS(I&U)R as "a valve for shutting off the supply of gas in an emergency, being a valve intended for use by a consumer of gas". Therefore, the more commonly used term, emergency control valve (ECV), is used in this publication. The outlet of the ECV denotes the end of the Network. Normally, the ECV is positioned at the inlet to the primary meter.*

*Note 2: Further guidance is given in IGE/G/1 and IGE/G/5.*

**TABLE 1 - RESPONSIBILITIES FOR INSTALLATION**

## PART 1 - TIMBER FRAMED BUILDINGS

### SECTION 4 : NETWORK PIPELINES

This section describes the measures to be taken when installing Network pipelines (see Note to Sub-Section 2.1). For the purposes of this section only, a "Network pipeline" embraces all Natural Gas and LPG pipelines upstream of the ECV.

*Note: An example of Network pipeline entry which passes under the ground floor, for example an entry to a block of flats with an internal masonry service duct and riser, is given in Figure 1. See IGE/G/5 for further details.*

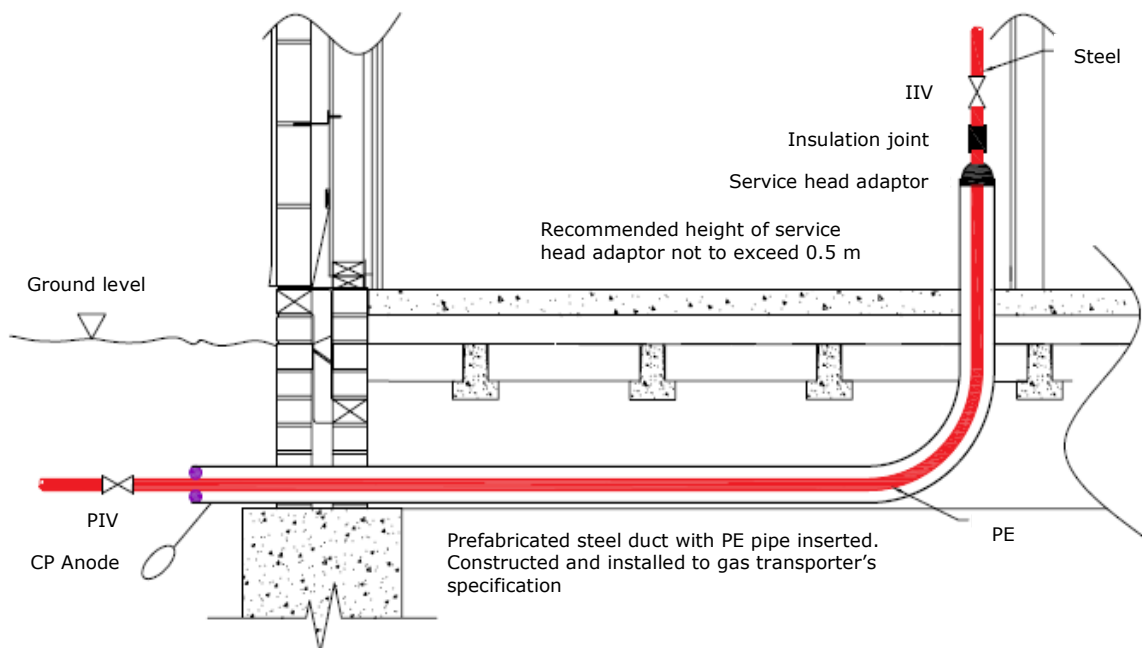
- 4.1 Any Network pipeline shall be designed and installed in accordance with IGE/TD/4 or IGE/TD/3 as appropriate and, additionally, IGE/G/5 for flats and other multi-dwelling buildings.

*Note: IGE/TD/3 does not cover the entry of Network pipelines into buildings. The principles of IGE/TD/4 apply where the Network pipeline is a "distribution main" and not a "service pipe" or "service pipework" or where the latter exceeds the maximum diameter of pipe addressed by IGE/TD/4.*

- 4.2 Allowance shall be made for differential movement (including timber shrinkage) in accordance with Appendix 3.5. Particular attention should be made in the design and installation to accommodate differential movement between the timber frame and any masonry or concrete structure, for example an external leaf or a stairwell, and the Network pipeline.

- 4.3 Differential thermal expansion of Network pipelines, and supporting materials, generally, shall be calculated for an ambient temperature variation of 30°C for internal pipes and 80°C for external pipes.

- 4.4 Wherever practicable, a Network pipeline should terminate on the left hand side of the proposed position for the meter as viewed when reading the meter.



**FIGURE 1 - NETWORK PIPELINE ENTRY FOR INTERNAL METERS IN A BLOCK OF FLATS**

## SECTION 5 : METER INSTALLATIONS

This section describes the measures to be taken when installing a meter installation and the routing of installation pipework from the meter installation.

### 5.1 GENERAL

5.1.1 The position of any primary meter should be agreed between the designer/contractor, the gas supplier, the GT and the meter owner, as appropriate.

*Note: Suitable meter boxes for domestic installations may be either built into a wall, surface mounted on a wall, semi-concealed into adjacent ground or installed in another purpose designed box.*

5.1.2 Any meter must be installed in compliance with GS(I&U)R and shall be installed in accordance with BS 6400, IGE/GM/6 or IGE/GM/8, as appropriate. Reference should be made to the ventilation requirements of all meter boxes and, in particular for LPG, the semi-concealed meter box buried in the ground or a well-type box.

5.1.3 Where a cladding of thickness less than 100 mm of masonry is used, any meter box shall be either surface mounted (see clause 5.2.2) or semi-concealed (see clause 5.2.3).

5.1.4 A meter box shall not be inset into a structural timber panel.

### 5.2 ROUTES FOR INSTALLATION PIPEWORK FROM EXTERNAL METER POSITIONS

#### 5.2.1 From a built-in meter box

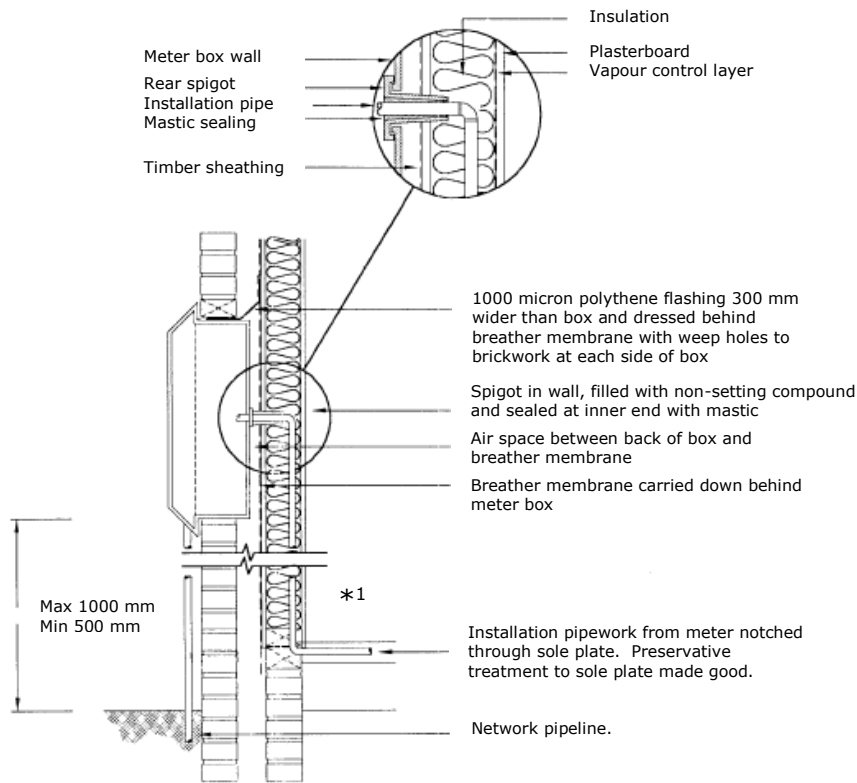
The following describes the routeing of installation pipework from a typical built-in meter box. The following steps shall be taken for each of the options given in clauses 5.2.1.1 to 5.2.1.3.

5.2.1.1 ***Via the proprietary rear spigot of the meter box - fully concealed*** (see Figure 2(a)) *not suitable for a Network pipeline of MOP exceeding 75 mbar*

- build the box into the outer leaf masonry
- cut the box spigot short just to pass through the timber sheathing
- drill hole through timber sheathing for the spigot. Elongate the hole upwards by at least 5 mm to accommodate any downward movement of the timber frame. Greater elongation may be required for higher buildings (see Figure 19)
- if necessary, drill or notch the bottom plate of the wall frame and the sole plate, removing as little timber as possible and not removing more than one third of the width of the bottom plate or sole plate
- treat any cut, notched or drilled surface of bottom plates or sole plates with an appropriate preservative to maintain the protection originally given to the timbers before construction.
- locate the pipework in a channel formed by timber noggings of the same depth as the timber frame (the principles for which are shown in Figure 5(b))
- route the installation pipework as close as possible to the plasterboard side and in a channel within the timber frame, i.e. on the warm side of the insulation
- minimise the number of joints in the pipework within the channel, for example on the one elbow behind the meter box, and do not use compression fittings in the channel. Ensure that the channel is not more than 100 mm wide and that it extends to the height of the top of the box spigot plus 50 mm
- seal the noggings with mastic and seal the gap between the pipework and the spigot with a non-setting compound
- where it is unavoidable to have electrical cable in the channel, route and clip the cable at least 25 mm from the pipework. Seal any points of channel penetration with a flexible fire-resistant compound

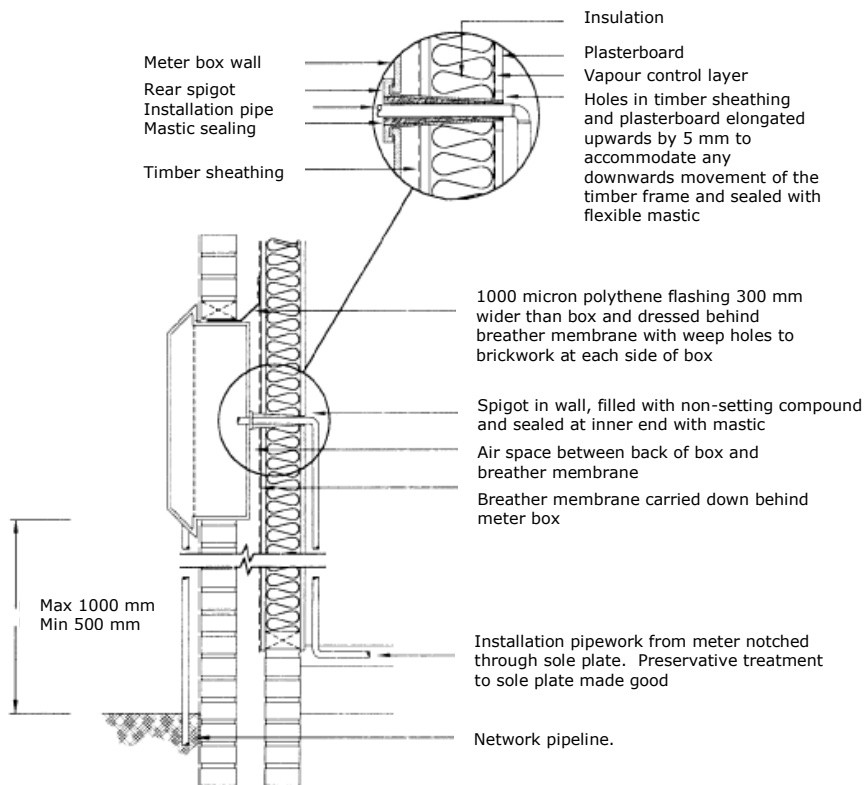


- protect the pipework as described in clauses 6.1.3 and 6.3.5
- re-instate the channel so that the insulation, vapour control layer (VCL) and plasterboard are to the same standard as the rest of the wall.



\*1 Note: The installation pipework is located within a channel within the wall.

**(a) Fully concealed**



**(b) Surface run**

Note: Neither of the above arrangements is suitable for a Network pipeline of MOP exceeding 75 mbar (see BS 6400-2).

**FIGURE 2 - PIPEWORK ROUTE VIA THE REAR SPIGOT OF A METER BOX**

5.2.1.2

**Via the rear spigot of the meter box - surface run i.e. concealed from outside** (see Figure 2(b)) not suitable for a Network pipeline of MOP exceeding 75 mbar

- build the box into the outer leaf masonry
- cut the box spigot flush with the inside (room) face of the plasterboard
- drill hole through timber sheathing for the spigot. Elongate the hole upwards by at least 5 mm to accommodate any downward movement of the timber frame. Greater elongation may be required for higher buildings (see Figure 19)
- seal the pipework into the spigot with flexible fire-resistant compound and seal the spigot into the wall with flexible mastic. Cut any hole in the VCL as small as possible to accommodate the spigot without providing a route for vapour to pass. Where the VCL is a polythene membrane, make the hole in the VCL 10 mm smaller than the spigot so that it makes a tight interference fit around the spigot
- make good the plasterboard with plaster or flexible fire-resistant compound so that there is no route for air movement into the inner leaf framework.

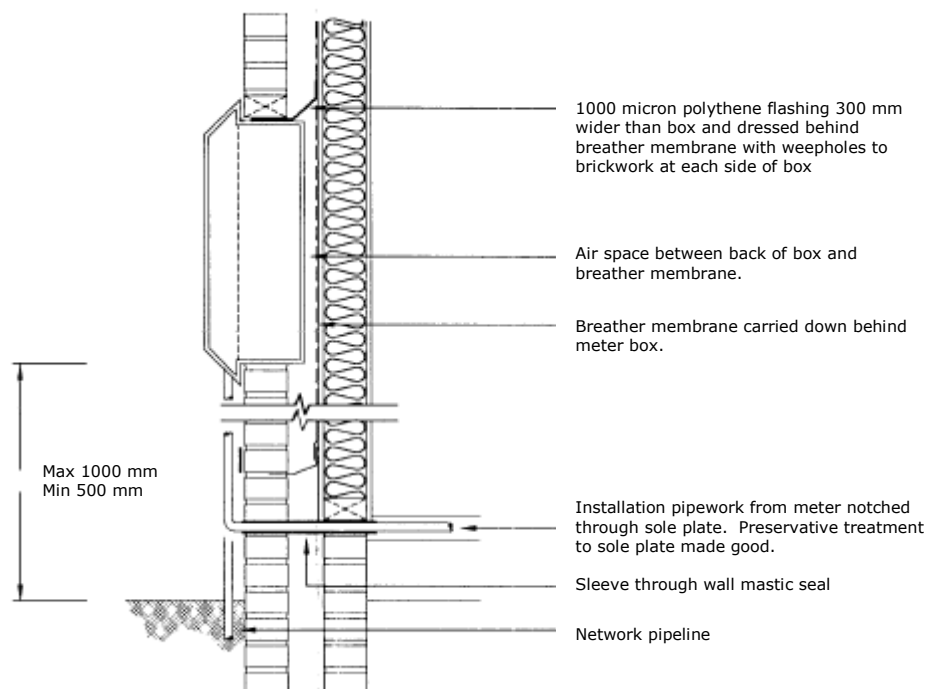
5.2.1.3

**Using an external route** (see Figure 3)

This method avoids penetration of the inner leaf framework behind the meter box by routing the pipework from the meter box down the outside of the building to the base of the wall, through a sleeve that crosses the outer leaf, the cavity and inner leaf, and passing directly into the wall or floor screed.

The following steps shall be taken:

- do not remove the rear spigot knockout panel on the meter box
- pass the installation pipework through the knockout panel in the base of the meter box
- route the pipework to a point on the building immediately above the damp-proof course
- pass the pipework (enclosed in a sleeve) through the wall. Route the sleeve through the sole plate in a slot cut as small as possible to accommodate the sleeve
- secure the sleeve in the masonry with mortar and seal the pipework within the sleeve with a flexible fire-resistant compound.



Note: This arrangement is suitable for a Network pipeline of MOP up to 2 bar (see BS 6400-1 and -2).

**FIGURE 3 - PIPEWORK ROUTE – EXTERNAL**

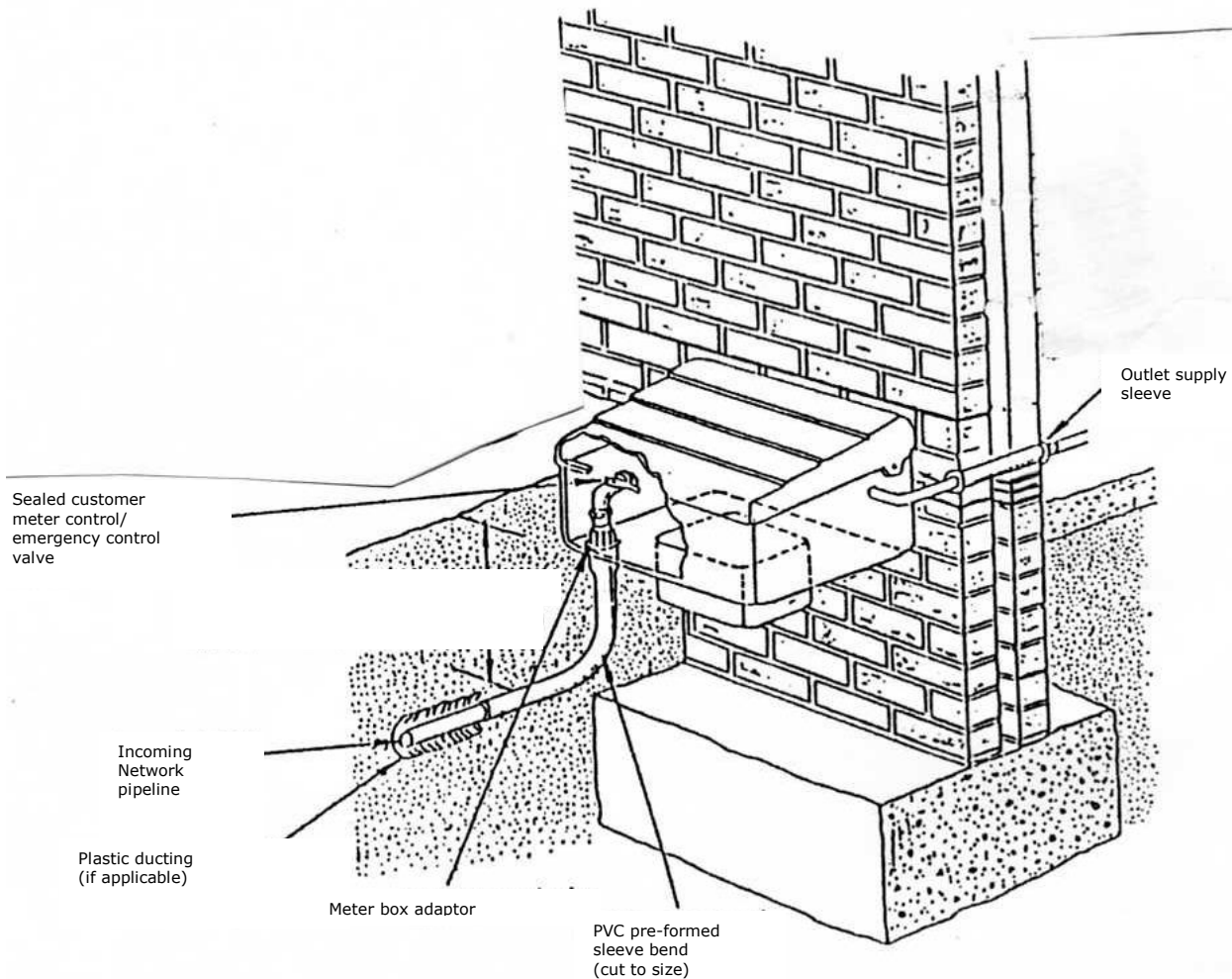
5.2.2 **From a surface mounted meter box**

Generally, for existing buildings, a surface mounted meter box is used. The box should be mounted on the external leaf i.e. the masonry. The pipework should enter the building immediately above the damp-proof course and, as it passes through the wall, it must be enclosed within a sleeve. The sleeve shall be routed through the sole plate in a slot cut as small as possible to accommodate the sleeve. The sleeve shall be secured in the masonry with mortar and the pipe must be sealed within the sleeve with a flexible fire resistant compound.

5.2.3 **From a semi-concealed meter box** (see Figure 4)

A semi concealed meter box is one designed to be installed into the ground adjacent to the external wall.

Pipework should enter the building immediately above the damp-proof course and in accordance with clause 5.2.2.



*Note: This arrangement is suitable for a service of MOP up to 2 bar (see BS 6400-1 and -2).*

**FIGURE 4 - PIPEWORK ROUTE (SEMI-CONCEALED METER BOX)**

## SECTION 6 : INSTALLATION PIPEWORK

This section describes the measures to be taken when installing gas installation pipework.

### 6.1 GENERAL

6.1.1 Installation pipework shall be installed in accordance with BS 6891 or IGE/UP/2, as appropriate or, for LPG, BS 5482-1.

Attention is drawn to the requirements of GS(I&U)R relevant to pipework in domestic, commercial and certain industrial premises. Of particular relevance is that pipework must not be installed in any duct or void that is not adequately ventilated.

*Note 1: Installation pipework is any pipework or fitting from the outlet of the meter installation to points at which the appliances are to be connected.*

*Note 2: Pipework may be surface fixed or laid within ducts, trunking, cupboards, suspended floors ventilated in accordance with the above standards and procedures, or it may be embedded in concrete floors.*

*Note 3: Areas for vents of ducts are given in BS 6891 and IGE/UP/2. For ducts with cross sectional areas up to 0.01 m<sup>2</sup>, for example 100 mm x 100 mm, no ventilation is required. Ducts have to be sealed from any cavity, wall or floor void through which they pass.*

6.1.2 The house designer/builders should establish the complete route of installation pipework from the meter to each appliance. In doing so, they should take into account where the pipes may be placed and consider how the pipes may be concealed or incorporated into the walls/floors without compromising fire, thermal, acoustic or structural features while achieving adequate ventilation. Work must comply with the building regulations for England and Wales, and Scotland, as appropriate.

If ducts or voids are to be used, they shall be adequately ventilated and protected. In taking these principles into account, the route may not necessarily be the shortest or most direct. For many 2 storey dwellings, appliances and, therefore, pipework may be confined to the ground floor. However, where it is necessary to install gas pipes in a storey above the ground floor, particular care should be taken to minimise the extent of horizontal runs in order to avoid complications of concealment.

Consideration should be given to running pipework:

- externally or
- vertically in purpose-designed, ventilated shafts or
- horizontally behind skirting boards or in small cross-section, appropriately ventilated, under-floor ducts

*Note: These ducts may be especially appropriate to pass under doorway openings.*

6.1.3 Pipework shall be installed such that:

- it does not interfere with any structural member of the building frame
- any fixing will not penetrate the pipework, for example plasterboard fixings, screws or shot fired nails which are typically 50 mm long. This may be achieved by ensuring that the pipe is installed more than 50 mm from the front face of the plasterboard or by using a metal plate for protection in front of the gas pipe.

6.1.4 Pipework shall be situated so that, in the event of a gas leak, gas is not capable of entering cavities within the structure where the leak could remain undetected.

- 6.1.5 Where a gas supply point is to be positioned on a separating or compartment (party) wall, any pipe shall rise in front of the finished plasterboard face. The detail shall be such that the fire resistance in that location is in accordance with the appropriate building regulations, for example AD B in England and Wales.

*Note: Usually, the plasterboard on such walls is 32 mm thick.*

- 6.1.6 Provision shall be made for pipework to accommodate any normal differential movement or shrinkage of the building, special attention being given to buildings of multi-storey construction (see Appendix 3.5 and IGE/G/5).

*Note: A suitable method of accommodating movement for gas installation pipework passing through a masonry wall is given in Appendix 6 as Figure 27.*

- 6.1.7 When working with a blowlamp or power tool or other source of heat in the vicinity of combustible material, for example timber, impregnated softboard, breather membrane etc., care shall be taken to avoid a fire hazard.

## 6.2 PIPEWORK IN OR UNDER FLOORS

### 6.2.1 Concrete floors

- 6.2.1.1 Where pipework is laid in, or in contact with, a concrete floor, it shall have protection or be protected against corrosion, either as manufactured or by application at the time of installation.

- 6.2.1.2 Pipework shall be located accurately in order to emerge from the floor slab at a position adjacent to a completed wall, allowing for the thickness of the timber framework and plasterboard.

- 6.2.1.3 Pipework shall be tested for tightness before the site application of any corrosion protection and before the pipe is made inaccessible.

*Note: IGE/UP/1, IGE/UP/1A or, usually, IGE/UP/1B or BS 5482-1 for LPG apply for tightness testing.*

- 6.2.1.4 Where a concrete floor is insulated by sheets of insulating material, for example expanded polystyrene, which is then covered by either wood based board or a sand/cement screed, the pipework should be laid in channels in the insulating material and be protected against corrosion.

### 6.2.2 Timber floors

Pipework shall not be installed within any compartment floor that separates one dwelling from another part of the building.

*Note: Refer to the relevant building regulations, for example England and Wales, Scotland or Northern Ireland.*

►Pipework shall not be installed between joists at intermediate floor levels unless there is sufficient adventitious ventilation available; ventilation shall be provided in accordance with BS 6891 or IGE/UP/2 Edition 2, as appropriate.

*Note: Research has indicated that where gas installation pipework (of diameter not exceeding 35 mm and at OP not exceeding 25 mbar) is installed at intermediate joisted floors in dwellings, there is sufficient adventitious ventilation of the floor construction to safely disperse any minor leakage of gas. Therefore, there is no requirement to install purpose provided ventilation to floors of this construction in timber frame or light steel frame buildings. The results and conclusions of this Report apply to Natural Gas installations only and, therefore, cannot be applied to installations supplied with 3<sup>rd</sup> family gases. ◀*

- 6.2.2.1 Where pipework is in contact with any material that may have a corrosive effect, the pipework shall have suitable protection.

- 6.2.2.2 Where it is necessary, during installation or retro-fitting, to remove a section of floor boarding or decking, the section shall be re-instated to the same standard as was the case before removal. Care shall be taken prior to lifting a timber

floor, by seeking specialist advice, as the floor may form part of the load bearing structure of a timber frame building.

Any cut edge of the floor decking shall be supported by noggings fixed between the joists.

Floor decking should be removed carefully and in small sections rather than whole floor lengths, to avoid interfering with the structural integrity of the building. It shall be replaced using fixings at the same spacing as before.

*Note: Typically, chipboard requires glued joints and also to be glued to the top of the joists.*

6.2.2.3 Where engineered I-joists are used, extreme care shall be taken if any floor decking is to be removed using a circular saw. The cutting depth shall be set carefully in order to avoid cutting into the joists.

The top and bottom flanges shall not be altered or damaged. They shall not be drilled or notched and any services should only pass either alongside or through the purpose-made holes or knock-outs in the web of the joist.

As floor cassettes using engineered I-joists are designed as an integrated unit, no alterations should be made to the decking or the joists (both top and bottom flanges and the webs) without obtaining the approval of the floor designer.

### 6.3 PIPEWORK IN OR THROUGH WALLS

Where it is not practicable to route pipework as described in Sub-Section 6.2, it may be installed within the timber frame structure. Figure 5 illustrates a typical pipework installation in an external wall.

Pipework in acoustic walls and floors should only be installed with the agreement of the designer.

*Note: Installation may mean the provision of special ducts to ensure no loss of acoustic performance.*

Reference should be made to "Robust Details" of Part E of the Building Regulations (England and Wales).

6.3.1 In general, pipework shall not be installed within any compartment (party) wall, nor shall any compartment wall be breached.

*Note: Any pipework in a compartment wall is likely to compromise the acoustic standards of the wall required by Building Regulations.*

6.3.2 Any pipework run within a wall should be as short as possible.

6.3.3 Vertical pipework shall be placed in a purpose designed channel (see Figure 5). Compression fittings shall not be used within such a channel.

*Note: It is advisable to minimise the number of joints within the channel.*

6.3.4 Pipework shall be secured to a stud using purpose made fittings.

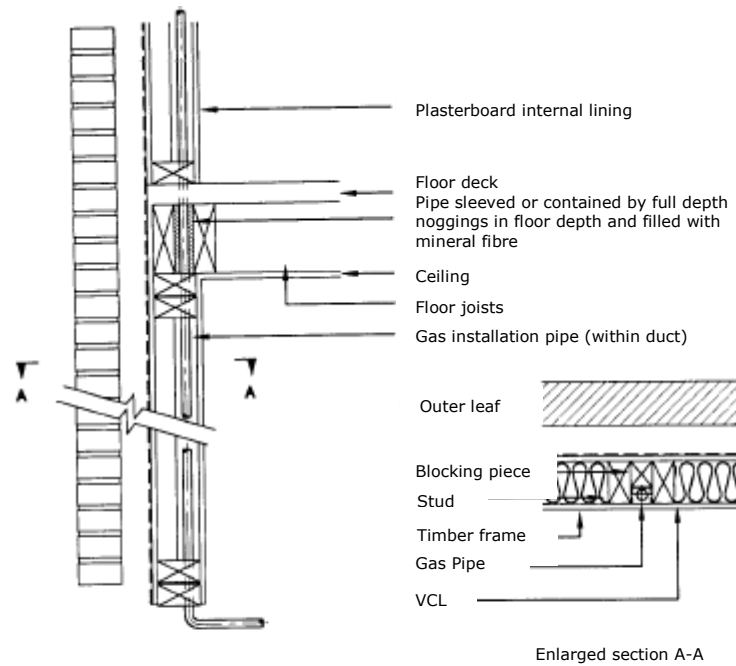
If any notching or drilling is proposed, the agreement of the designer shall be obtained (where practicable) before taking such action.

6.3.5 Where thin wall metallic pipe, for example copper and corrugated stainless steel, is run within 50 mm of plasterboard, it shall be protected suitably against penetration, for example with a steel plate of thickness 1 mm (see Figure 5(b)).

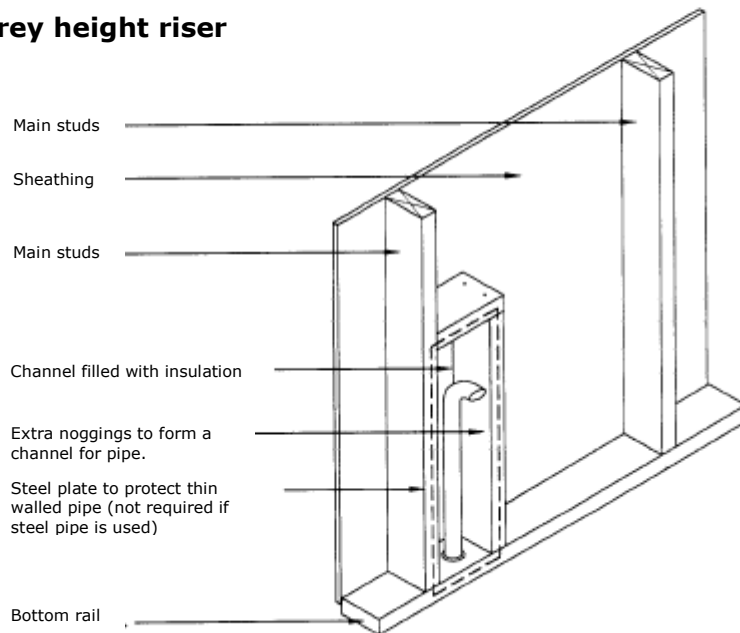
*Note: This principle applies to an external or internal wall, but note that pipework in an internal wall may be within 50 mm of both sides of the wall.*

Studs shall not be notched. Where studs, rails or noggings are to be drilled to permit routing of gas pipework, any hole shall be as small as possible and be positioned in accordance with Appendix 3.4 and within the zones set out in Figure 21.

- 6.3.6 Any pipework channel shall be filled with insulation and, for an external wall, covered with the VCL. The channel and/or VCL shall then be covered with plasterboard and finished to the same standard as the remainder of the wall.
- 6.3.7 Any perforations of the VCL shall be made good with an adhesive tape.



**(a) Storey height riser**



**(b) Appliance fixing point riser**

*Note: If the installation is on an internal wall and the gas pipe is copper or CSST, an additional steel plate will be required on the other side of the wall if the pipe is within 50 mm of that side.*

**FIGURE 5 - PIPEWORK IN A TIMBER LEAF**

## SECTION 7 : APPLIANCES

This section describes measures to be taken when installing a gas appliance in a timber framed building. Any technique adopted will depend upon whether or not the building structure caters for appliance installation. For example, purpose designed framing, included during the construction of a building, will make subsequent appliance installation easier and more controlled.

### 7.1 GENERAL

7.1.1 The appliance manufacturer's instructions shall be consulted and observed where they apply. If the instructions make no special reference to aspects of installation in a timber framed building, the following procedures shall be adopted.

7.1.2 No part of an appliance except a room sealed chimney system, for example balanced flue assembly, shall penetrate the timber frame leaf.

*Note:* A room sealed chimney system for an appliance is permitted to penetrate the timber frame leaf, provided it is installed in accordance with the manufacturer's instructions or Section 8 of these Procedures.

### 7.2 COMBUSTIBLE WALL SURFACES

7.2.1 The appliance manufacturer's instructions shall be consulted to determine how an appliance can be fitted on a combustible wall.

*Note 1:* Some appliance standards require the appliance to be suitable for fitting directly to a combustible surface. Other standards allow the manufacturer to declare whether or not the appliance is suitable for fitting directly to a combustible surface, for example BS EN 483 requires the installation instructions for type C boilers that raise the temperature of a test wall by more than 60 °C to state the nature of protection which has to be applied between:

- the boiler and the floor or walls when these latter are made of flammable materials, and
- the flue duct and air inlet supply duct and a wall when the wall is constructed of inflammable material.

*Note 2:* Many gas appliances may be installed on or adjacent to a combustible wall because they have satisfied fire hazard and limiting temperature clauses of appropriate Standards.

7.2.2 If an appliance is not permitted to be fitted directly to a combustible surface, or if suitability cannot be confirmed, it shall be separated from the timber frame by a minimum 75 mm air gap or by a minimum 25 mm thickness of non-combustible material.

*Note:* Where there is a plasterboard surface, the latter may be achieved effectively by adding a sheet of fibre cement board or similar non-combustible material of minimum thickness 12.5 mm to the 12.5 mm thick sheet of plasterboard on the timber frame or by a method certified by the appliance manufacturer.

### 7.3 SUPPORT OF APPLIANCES

#### 7.3.1 General

A suitable method of supporting a wall hung appliance shall be used, as described in Appendix 5. Studs are structural components and shall not be cut or altered without the approval of the designer/builder.

Fanned flued fires may be supported directly on hearths that comply with Building Regulations. If the hearth governs the height at which the chimney assembly penetrates the wall, care shall be taken to ensure that the minimum separation from combustible surfaces is maintained (see Sub-Section 7.2 and clause 8.3.1).



### 7.3.2 **Existing buildings** (see Figure 6)

7.3.2.1 An appliance should be mounted using any of the following methods, full details of which are provided in Appendix 5:

- screwed into studs (A5.1)
- screwed into noggings behind the plasterboard (A5.2 and Figure 7)
- fixed to a non-combustible sheet mounted in front of the plasterboard (A5.3)
- mounted on the plasterboard wall using proprietary load spreading fixings (A5.4). This method is not recommended except for very light-weight appliances. Appliance and plasterboard manufacturers' should be consulted concerning load bearing capacity

*Note: In any of the above options, the fixing method selected should be capable of supporting the appliance and strengthened, if necessary, as in clause 7.3.3.*

7.3.2.2 The timber studs are the principal structural members of the wall and, wherever possible, fixings should be made directly into the studs.

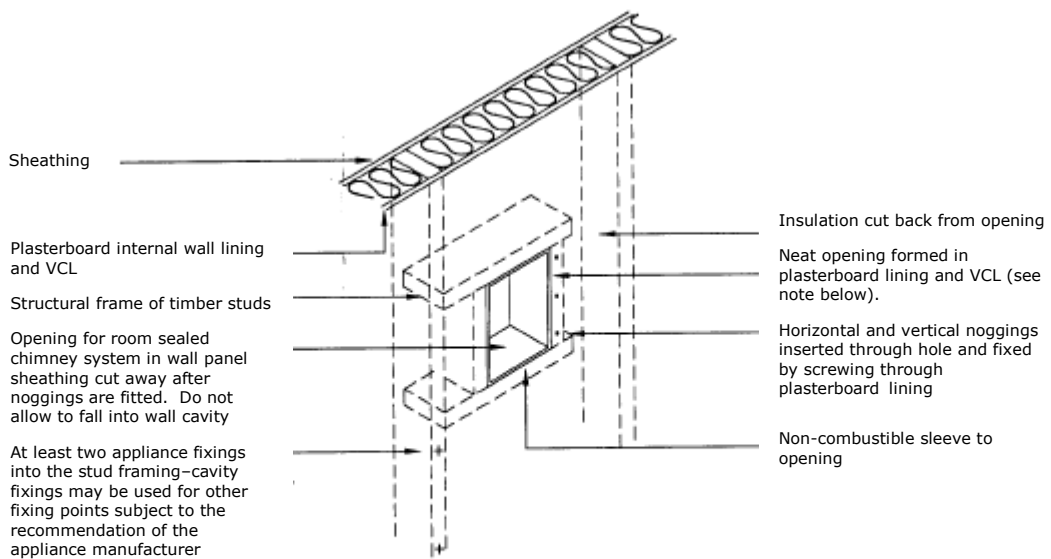
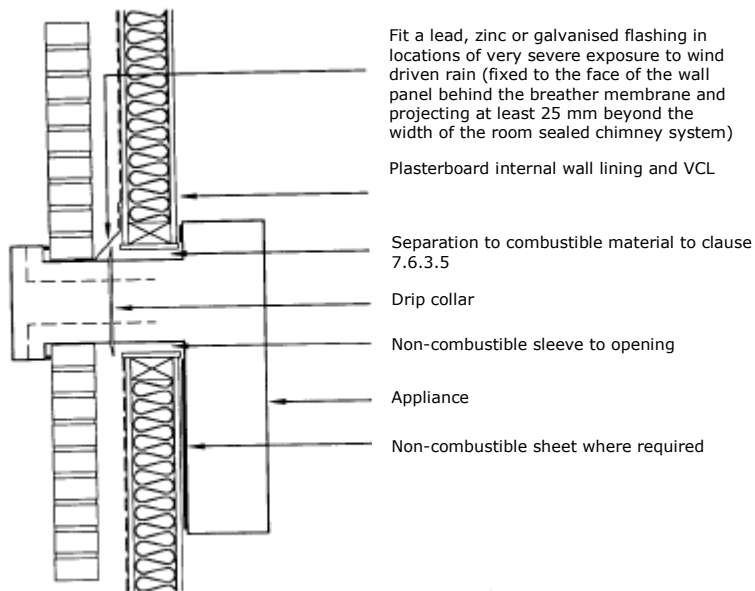
*Note: The wall studs, generally, occur at either 400 mm or 600 mm centres, although other dimensions occur especially at wall panel intersections and adjacent to door and window openings. The stud positions in the wall can be found by:*

- tapping the wall surface to locate hollow and solid areas
- using a metal detector to locate the plasterboard nails or screws
- using a density meter (commonly called a stud finder) which identifies the solid sections.

### 7.3.3 **New buildings** (see Figure 7)

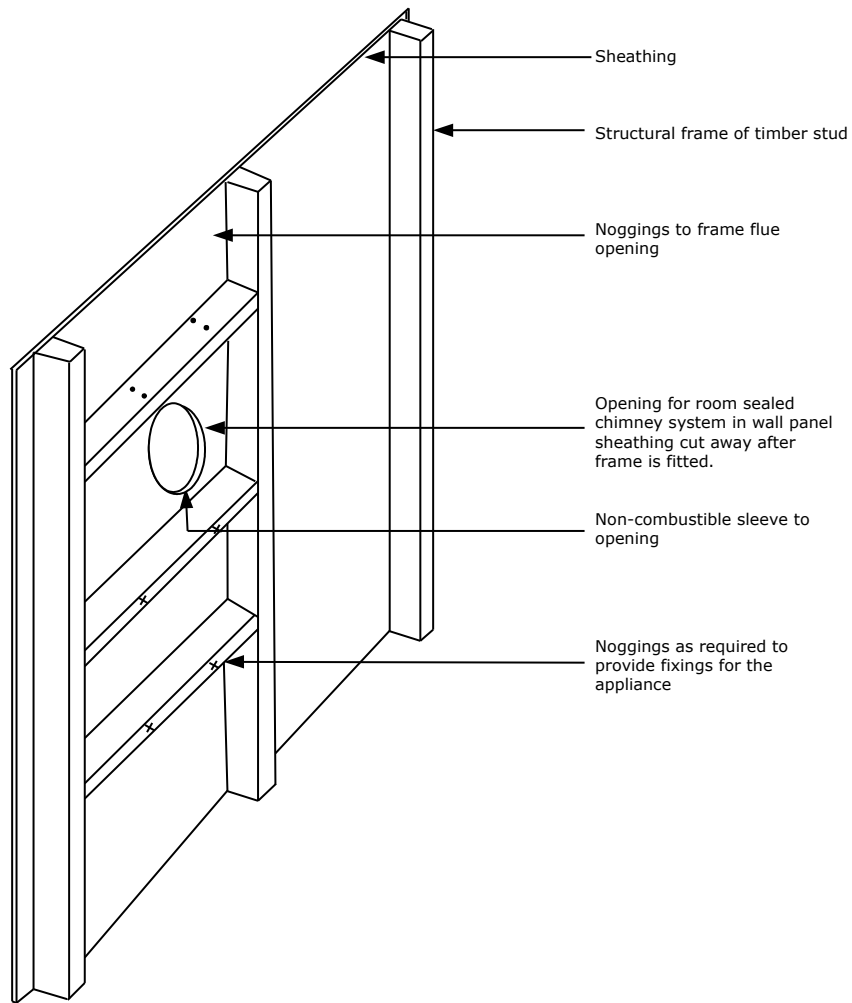
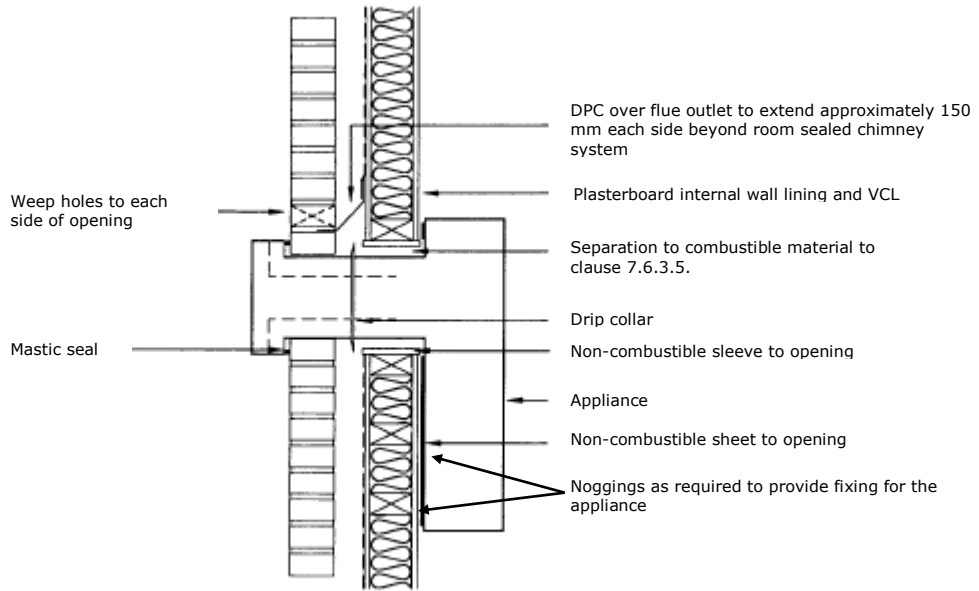
The builder should cater for the appliance, wherever possible, by incorporating a purpose designed frame such as that shown in Figure 7. The frame shall be capable of supporting the full weight of the appliance in its operational mode. Some combination boilers, for example, contain a significant weight of water.

Copyright © 2008, IGEM. Licensed copy: IGEM Online Standards. Not to be reproduced.



Note: Fit circular sleeve for appliance with circular flues. For further details, see Figures 7-11.

**FIGURE 6 - FITTING A WALL MOUNTED ROOM SEALED APPLIANCE ON AN EXISTING TIMBER FRAME EXTERNAL WALL**



**FIGURE 7 - FITTING A WALL MOUNTED ROOM SEALED APPLIANCE ON A PURPOSE DESIGNED FRAME**

## 7.4 VAPOUR CONTROL LAYER (VCL)

7.4.1 The VCL is an important feature of timber frame construction and its integrity shall be unaffected upon completion of the installation process.

Normally, a VCL is located on the warm side of the insulation and may be polythene sheet material or be an integral part of the plasterboard wall lining (vapour control plasterboard).

7.4.2 When penetrating any external wall having a VCL, for example to install a room sealed chimney system (balanced flue assembly), the cut edge of the VCL should be made good as carefully as is practicable. This should be achieved as follows:

- when the wall has a separate VCL (polythene sheet) and the room sealed chimney system has a circular or rectangular sleeve, cut the hole in the VCL 10 mm undersize so that the sleeve forms an interference fit in the hole. If possible, insert the sleeve into the wall 10 mm beyond its final position and then withdraw it to the final position to ensure that the VCL has not been pushed away from the plasterboard. With a rectangular sleeve, take care not to tear the corners of the holes. Make good any remaining gaps between the sleeve and the plasterboard with a suitable sealant, or plaster, or by fitting a flange to the sleeve and using a gasket.
- when the wall has a VCL bonded to the plasterboard, cut the hole for the sleeve as small and as accurately as is practicable and seal any gap carefully with a suitable sealant or by fitting a flange to the sleeve and using a gasket.

Any other damage to the VCL, not covered above, for example any accidental tear, should be made good with an adhesive tape.

7.4.3 Some types of timber frame wall, for example internal sheathed walls or warm wall constructions, do not have a VCL. In such cases, any gap shall be sealed completely after installation.

## 7.5 PROVISION OF AIR

Improved construction techniques and energy conservation measures are tending to lead to buildings of greater air tightness than in the past. The provision of air for combustion, in particular for open flue or flueless type appliances, needs to be sufficient to take account of this.

7.5.1 BS 5440-2 provides details of the air provision requirements of appliances of rated heat input not exceeding 70 kW net.

7.5.2 BS 5440-1 specifies methods of testing for spillage of open flue appliances. Such testing shall be meticulously carried out to a satisfactory conclusion to ensure the adequacy of the provision of air and effective operation of the flue.

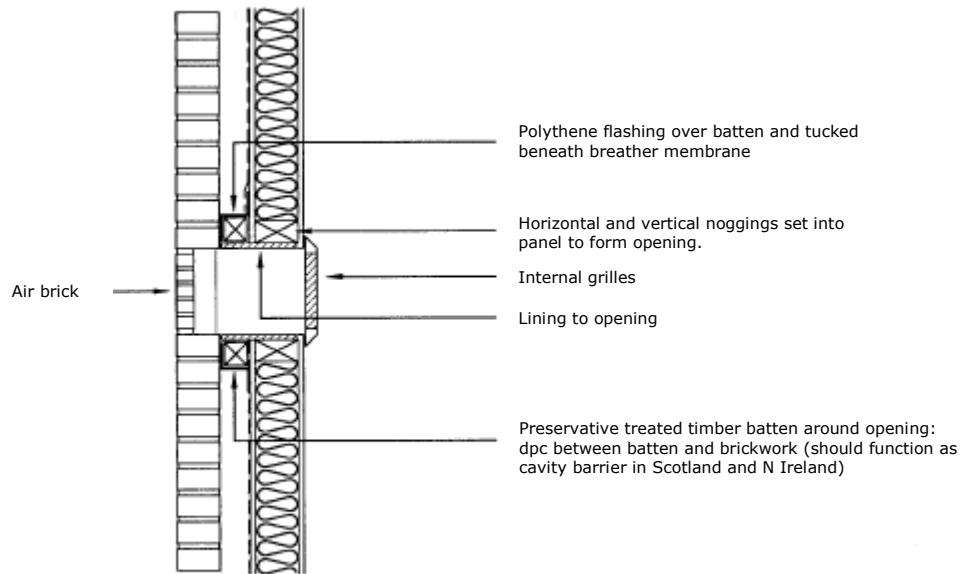
7.5.2 If there is any doubt concerning the level of adventitious ventilation and the provision of additional ventilation is not viable, a room sealed appliance shall be selected.

7.5.3 Some appliance types, for example DFE fires, may have special requirements for air supply and the manufacturer's instructions shall be complied with in all cases. BS 5871-1, 2 and 3 provide details of the ventilation requirements for decorative and other fuel effect gas fires.

7.5.4

Where specified at the time of construction, any air vent should be installed as shown in Figure 8. When using a cavity-bridging device, differential movement of the inner timber leaf with respect to the outer brickwork leaf shall be accommodated (see Appendix 3.5).

*Note:* Such movement may be accommodated by using mastic above and below the ventilator and/or arranging the telescopic sections such that the outer end can swivel upwards as the inner end moves downwards.



**FIGURE 8 - INSTALLATION OF A VENT**

*Note:* For an existing construction, use a proprietary ventilator.

7.6

**INSTALLATION OF A ROOM SEALED APPLIANCE, FOR EXAMPLE A BOILER**

7.6.1

**General**

Whenever appliance manufacturers give specific dimensions for siting chimney terminals, the quoted dimensions should be followed. However, if the manufacturer's instructions do not give specific dimensions, reference should be made to BS 5440-1 and appropriate building regulations.

In any event, it shall be ensured that:

- any terminal is positioned such that the combustion products will disperse freely at all times
- any plumbing/combustion products from any terminal will not cause a nuisance
- if a room sealed chimney system terminal is to discharge onto a passageway or pathway or over an adjoining property, combustion products will not cause a nuisance and the terminal will not obstruct the passageway. Compliance must be made with any local by-laws covering minimum height for projections from a wall above a public footpath and/or termination over adjoining land.
- care is taken when marking out the position of a room sealed chimney system prior to cutting through the wall, especially in the case of a condensing appliance where a fall of 3° is required back into the appliance.

7.6.2 **VCL**

The VCL should be protected during the installation of the chimney system. The procedures in Sub-Section 7.4 apply.

7.6.3 **Installation anticipated at building design or construction stage**

7.6.3.1 A suitable location for any appliance should be determined and appropriate provision made for installation, for example by the use of a purpose-designed panel.

7.6.3.2 Any such provision shall enable the chimney terminal to be positioned satisfactorily on the outside wall or roof in accordance with BS 5440-1. In addition, the method shall enable satisfactory support and location of the appliance and leave sufficient room to connect any gas, water or condensate pipes and to facilitate servicing.

7.6.3.3 For room sealed appliances, the chimney system (whether concentric or separate air supply and flue ducts) will pass through combustible material in the wall (see Figure 9). These assemblies or ducts shall be surrounded by a sleeve of non-combustible material at the point where it enters the wall. This sleeve shall extend to be at least flush with the breather membrane/timber sheathing but should not protrude more than 10 mm into the cavity. Provision shall be made to accommodate any differential movement of the inner leaf of the wall.

*Note: If the sleeve protrudes greater than 10 mm into the cavity, it may collect dampness on the timber sheathing and defeat the function of any drip feature.*

7.6.3.4 The sleeve around a room sealed chimney system will prevent gross air penetration into the insulation space within the timber frame. In order to minimise the effect of penetrating the VCL, any hole in the VCL should be cut 10 mm undersize where possible and the sleeve forced through with care.

7.6.3.5 The appliance manufacturer's instructions shall be consulted to determine the separation distance between the room sealed chimney system and any combustible material.

Where no specific instructions are available, the default dimensions shall be:

- at least 25 mm for a concentric room sealed system serving a natural draft appliance, or
- at least 10 mm for a concentric room sealed system serving a fanned draught or condensing appliance, or
- at least 10 mm around the flue duct for a condensing appliance with separate air supply and flue duct, and zero for the corresponding air supply duct.

*Note: The dimension of the gap is measured between the outer surface of the room-sealed chimney system and the sleeve or, for a separate air supply and flue duct, between the outer surface of those ducts and the sleeve.*

*The term concentric also includes those systems where the air supply duct is contained within the flue duct but does not share a common axis.*

7.6.3.6 The annular gap between the room sealed chimney system and the sleeve shall be sealed to prevent air (and heat and moisture) passing along it and, where practicable, filled with fibre insulation material to retain the thermal performance of the wall.

*Note: The sealing of the gap may be achieved by using a sheet of non-combustible material. Alternatively, some appliance manufacturers may provide their own sealing by a rope or similar seal of non-combustible material trapped between the appliance back plate and the inner wall face.*

7.6.3.7 If the outer leaf of the building is combustible, for example of shiplap boarding, then a metal or other non-combustible end plate should be used to maintain the terminal in position and provide an overlap on the outer side. Such an end plate should extend radially at least 50 mm beyond the edge of the terminal (see Figure 9(b)).

*Note: It may be necessary to increase considerably the size of an end plate in order to protect against discoloration or distortion of any painted or plastic wall boarding*

7.6.3.8 It shall not be possible for water to be transported across to the inner leaf of the building. One of the following methods shall be employed when installing the room sealed chimney system:

- a damp-proof membrane should be incorporated at the time of construction
- fitting an appliance with a circular room sealed chimney system by using a drip collar (see Figure 10(a)). This may be fitted onto the assembly by the appliance manufacturer or during installation by (i) wrapping a wire (of a material which will not promote corrosion) tightly around, and twisting the ends together below the room sealed system, or (ii) moulding a bead of mastic around the room sealed system
- fitting an appliance with a rectangular room sealed system by fitting a sloping plate above the room sealed system (see Figure 10(b)).

*Note: The plate can be held in place at the outer leaf and needs to be of a durable material extending about 25 mm to both sides of the room sealed system, with a downward slope across the cavity from the timber sheath to the outer leaf of about 45°.*

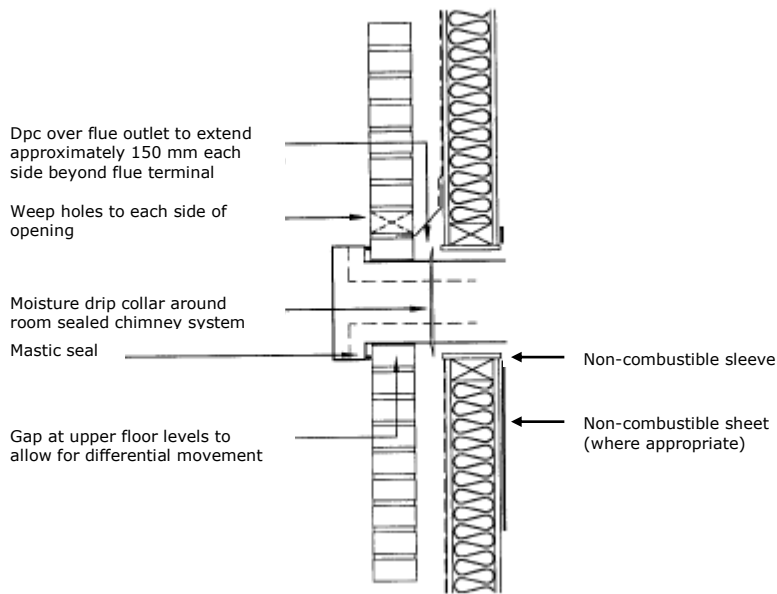
7.6.3.9 Provision shall be made for differential movement (see Appendix A3.5).

#### 7.6.4 **Installation after the building has been constructed**

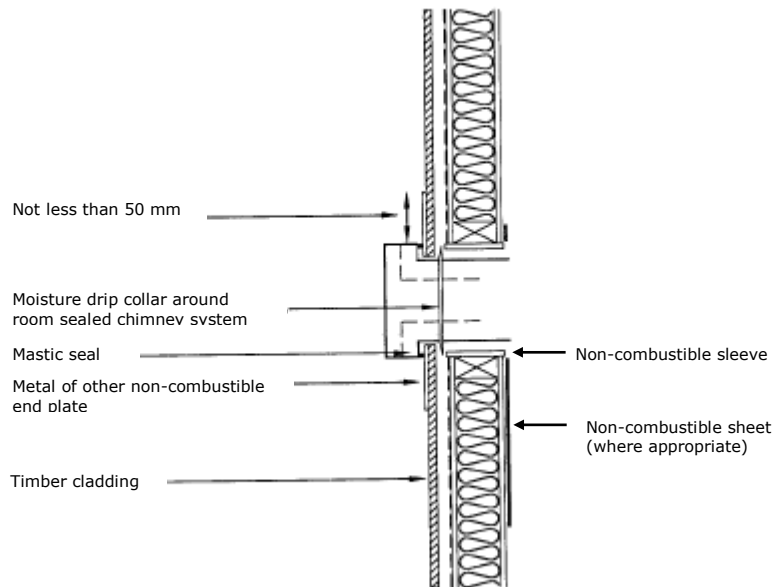
The steps outlined in clauses 7.6.3.2 to 7.6.3.8 should be applied and reference made to Appendix 3. A technique for cutting into the inner leaf is shown in Figure 11.

*Note: Provision for differential movement (clause 7.6.3.9) is not necessary for existing buildings where sufficient time (usually not less than 1 year following completion of construction) has elapsed for any timber movement to have occurred.*

Copyright © 2008, IGEM. Licensed copy: IGEM Online Standards. Not to be reproduced.



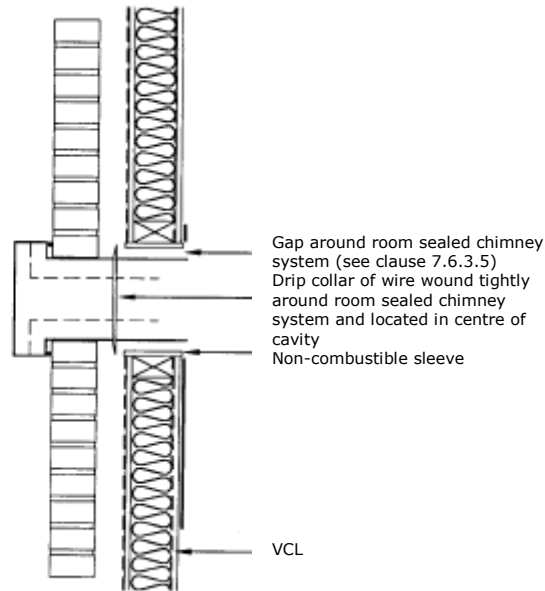
**(a) In a brick clad wall**



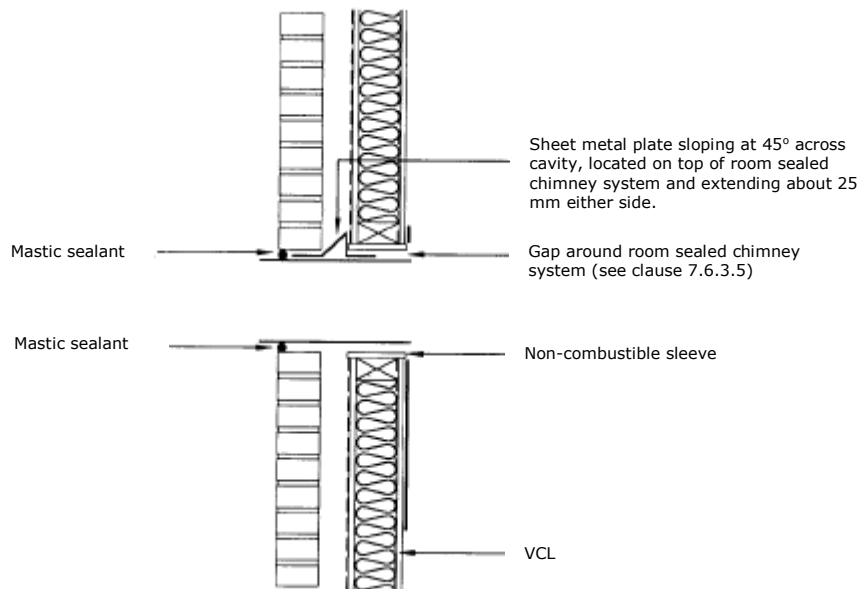
**(b) In a timber clad wall**

**FIGURE 9 - INSTALLATION OF A ROOM SEALED CHIMNEY SYSTEM TERMINAL**



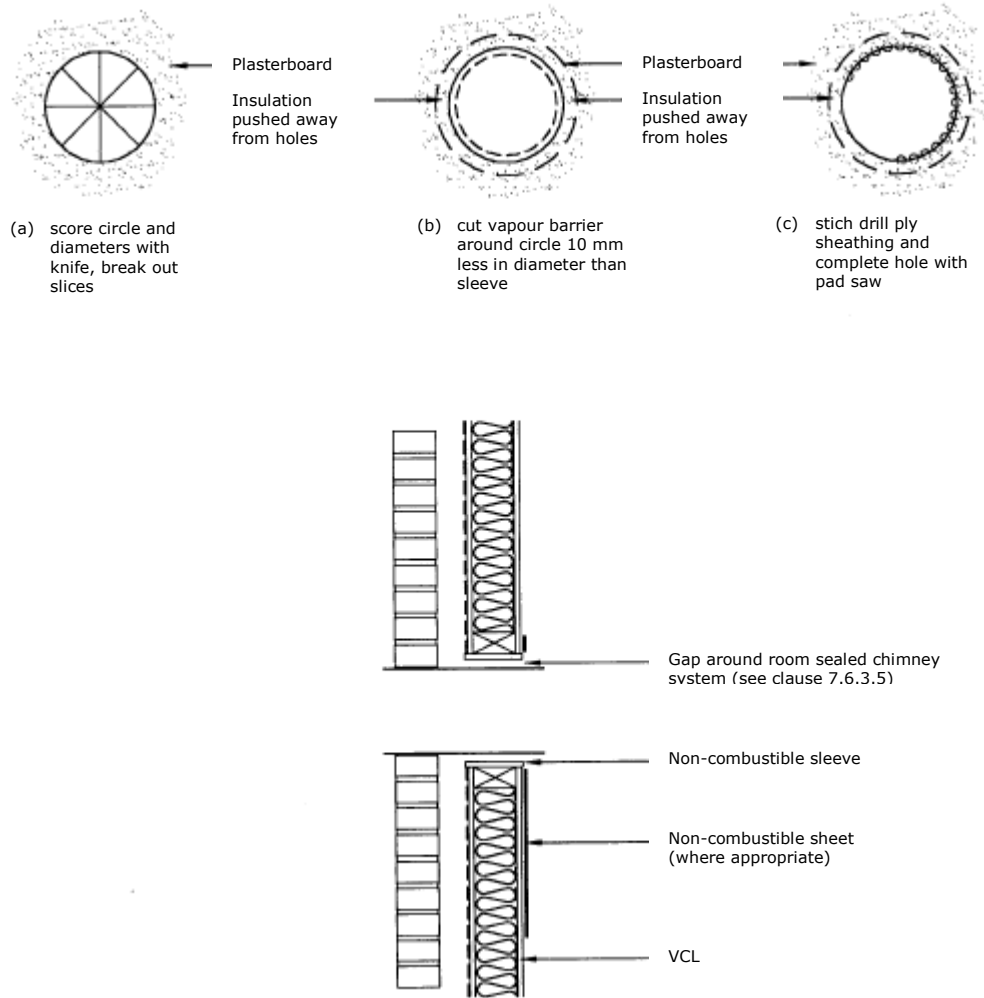


**(a) Drip collar for circular room sealed chimney system**



**(b) Sloping plate for rectangular room sealed chimney system**

**FIGURE 10 - MOISTURE TRANSPORT PREVENTORS**



**FIGURE 11 - INSTALLATION OF A ROOM SEALED CHIMNEY SYSTEM TERMINAL (CIRCULAR) THROUGH AN EXISTING TIMBER FRAME**

### 7.6.5 Removal of an existing appliance

Where an existing open flue or room sealed appliance is removed, one of the following options (clauses 7.6.5.1 to 7.6.5.3) applies. Work should be compatible with the original construction specification.

- 7.6.5.1 If no replacement appliance is to be fitted, care should be taken to ensure that all previous provisions made to accommodate the original appliance installation are made good as described in clause 7.6.5.4.
- 7.6.5.2 If a similar sized appliance is to replace the original one, the normal installation procedure should to be followed.
- 7.6.5.3 If a smaller sized appliance/room sealed chimney system is to be installed, consideration should be given to reinstating the wall as described in clause 7.6.5.4 and then installing the appliance in accordance with clause 7.6.4, using an appropriate appliance support (extra board and noggings within the wall).
- 7.6.5.4 All internal and external surfaces should be made good. The timber sheathing should be repaired or patched. The cavity space left through the removal of the original appliance room sealed chimney system should also be insulated with a fibre insulation material to retain the thermal performance of the wall and the VCL should be repaired to maintain control of moisture within the wall.

*Note:* A section of plasterboard may need to be replaced and any joints made good.

Following installation, the integrity of the following should be preserved:

- inner plasterboard
- VCL
- insulation
- timber sheathing
- cavity
- outer leaf (brick work or cladding).

## SECTION 8 : CHIMNEYS

### 8.1 PRELIMINARY CONSIDERATIONS

In selecting a type of gas appliance to be used, the house designer has to decide if an open flue chimney is required for primary central heating and / or any supplementary appliances and incorporate requirements into the overall design. In England and Wales, Parts L and J of the Building Regulations impinge on the selection and installation of appliances and how they are to be flued. In Scotland, Technical Handbooks (section 3, Environment and section 6, Energy) provide similar advice for ways of complying with the Building (Scotland) Regulations.

The options include:

- selecting a versatile chimney which can be used by a variety of unspecified open flue appliances for gas, oil or solid fuel. This will be sized for solid fuel, viz. typically with a 200 mm or larger diameter flue
- selecting a chimney specifically for a gas appliance, for example pre-cast concrete flue blocks which do not require a chimney breast
- not installing a chimney but providing a location for an appliance and its room sealed chimney system assembly and leaving the flueing to the appliance installer
- making no provision for gas appliances.

This section describes:

- metal chimney or masonry options for unspecified open flue appliances (see Figures 12 and 15) and
- pre-cast concrete flue block chimneys (see Figure 13).

Where room sealed chimney systems are supplied with the appliance, for example for room sealed (including balanced flue) boilers or fires, the flueing details are described in Section 7.

### 8.2 CHIMNEY TERMINOLOGY

#### 8.2.1 Definitions

It is important to be aware of the definition (for the purpose of these Procedures) of each term used since they relate to relatively new and unfamiliar terms used in European chimney standards.

#### **Chimney**

Structure consisting of a wall or walls enclosing a flue or flues.

*Note: This includes chimneys of all materials, for example metal, masonry, plastic etc. for use with either open flued or room-sealed appliances.*

#### **System chimney**

Chimney, for example open flue chimney, that is installed using a combination of compatible chimney components, obtained or specified from one manufacturing source with product responsibility for the whole chimney.

#### **Room sealed chimney system (previously referred to as a room sealed flue assembly)**

Complete assembly of room sealed flue duct and air supply duct as provided by the manufacturer of the appliance.

**Flue**

Passage for conveying the products of combustion to the outside atmosphere.

**Flue liner**

Wall of a chimney consisting of components, the surface of which is in contact with products of combustion.

**Connecting flue pipe**

Pipe that connects an appliance outlet to a chimney flue.

**Flue blocks**

Factory made pre-cast concrete or clay flue blocks.

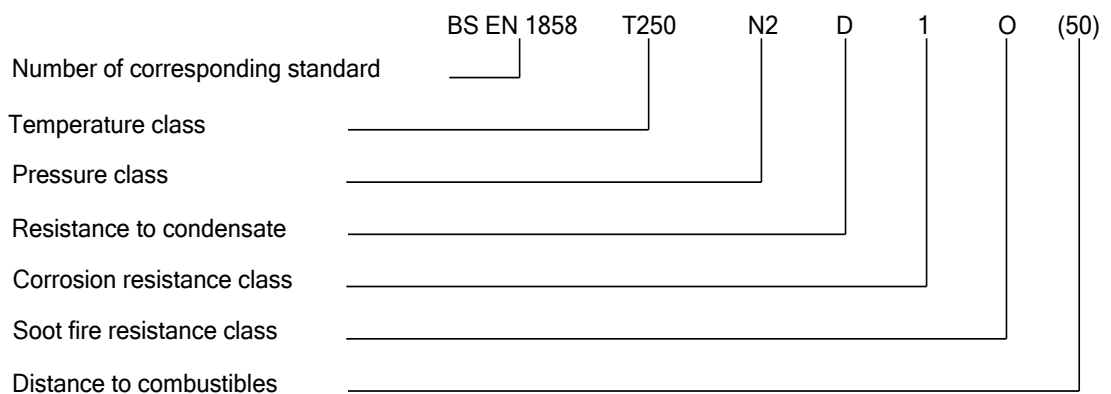
8.2.2

**Chimney designations**

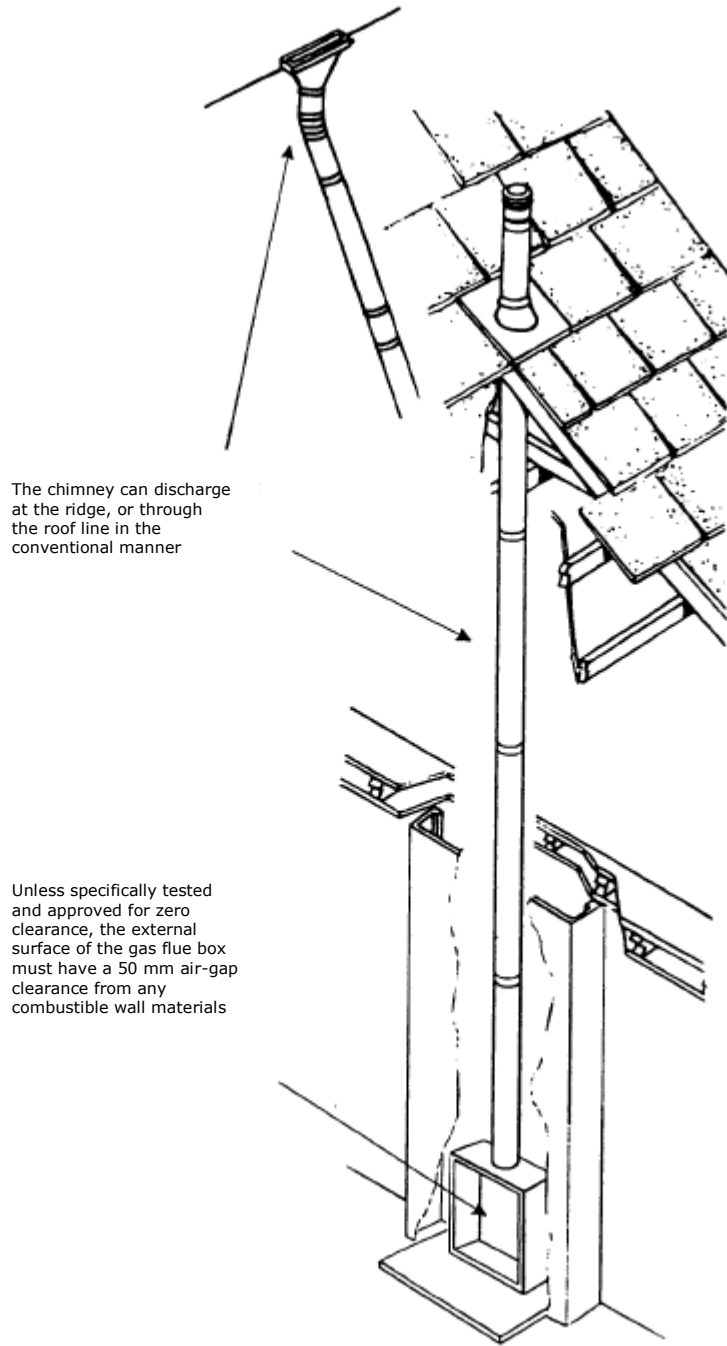
BS EN 1443 requires flue product manufacturers to provide a designation containing useful information to assist in the design of a flue using their products. Such designations are required by Building Regulations to be displayed on chimney plates in order to inform subsequent tradesmen to understand the characteristics of the chimney and select an appropriate appliance. The designation is set out as a code which relates to the performance characteristics of the product.

- the required characteristics for a gas flue block are:
- number of corresponding standard: for example BS EN 1858 for concrete flue blocks
- temperature class: the normal maximum working temperature
- pressure class: N1 or N2 for natural draught fires
- resistance to condensate: the ability to be used in condensing flue conditions (W for wet flues D for dry flues)
- corrosion resistance class: the ability to withstand acidic condensate (Class 1, 2 or 3 for Natural Gas flues)
- soot fire resistance class: designated G for soot fire resistant, O for not soot fire resistant. Can use O designation with Natural Gas
- distance to combustibles: the minimum distance to the surface of combustible material from the external surface of a flue block or system chimney.

Example designation for a concrete gas flue block:



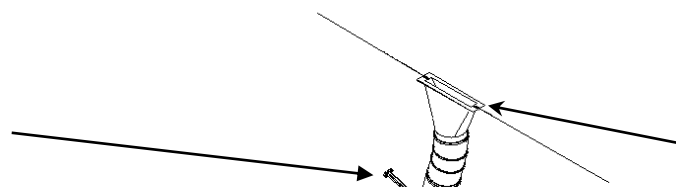
This flue block could also be referred to as a type B flue block according to the abbreviated designation contained in BS EN 1857.



The chimney can discharge at the ridge, or through the roof line in the conventional manner

Unless specifically tested and approved for zero clearance, the external surface of the gas flue box must have a 50 mm air-gap clearance from any combustible wall materials

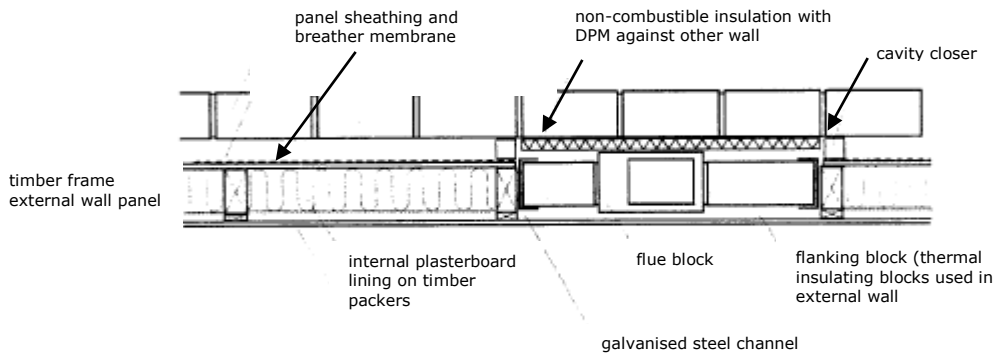
**FIGURE 12 - PROPRIETARY METAL SYSTEM CHIMNEY**



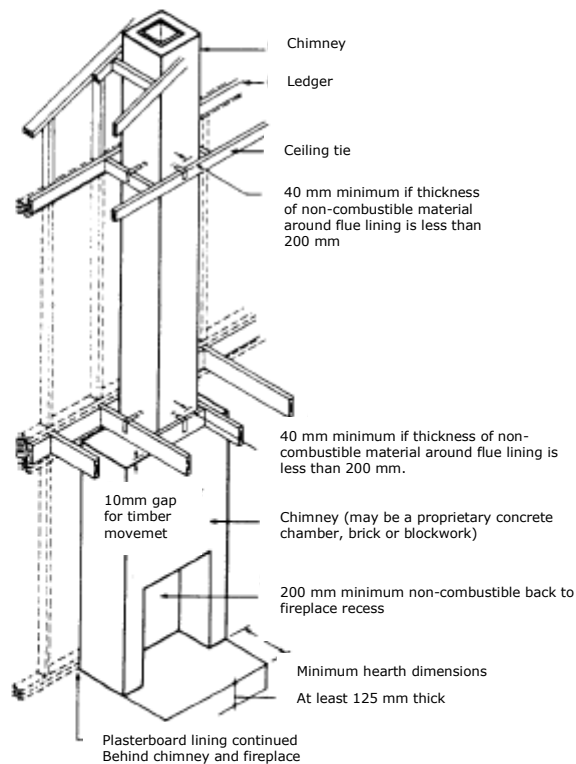
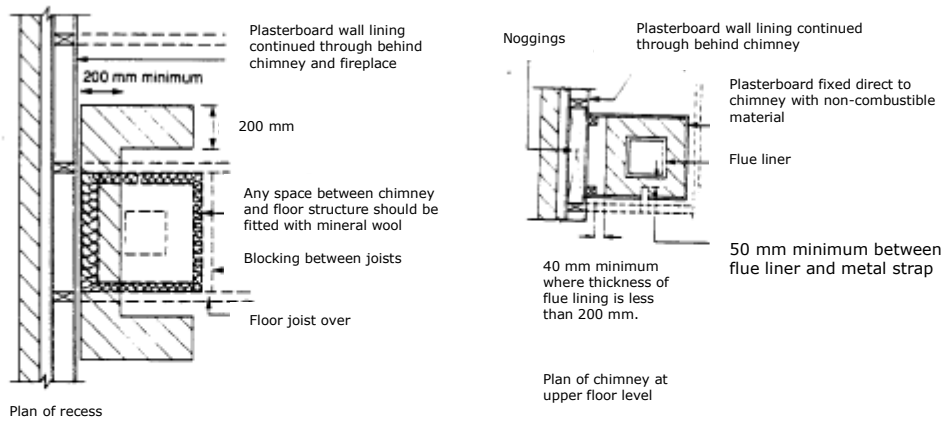
**FIGURE 13 - PROPRIETARY PRE-CAST CONCRETE BLOCK CHIMNEY SYSTEM**

**FIGURE 14 - SECTION THROUGH PROPRIETARY PRECAST CONCRETE FLUE SYSTEM TIMBER FRAMED EXTERNAL WALL**

**FIGURE 13 - PROPRIETARY PRE-CAST CONCRETE SYSTEM CHIMNEY**



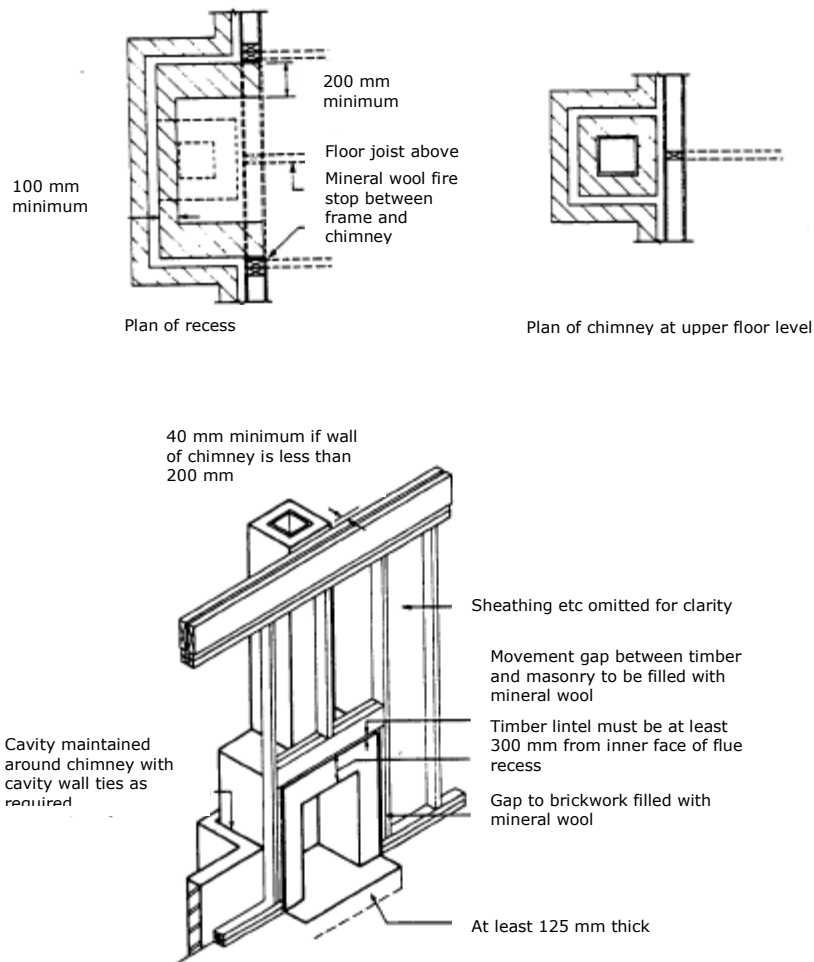
**FIGURE 14 - SECTION THROUGH PROPRIETARY PRE-CAST CONCRETE BLOCK CHIMNEY IN TIMBER FRAMED EXTERNAL WALL**



**FIGURE 15 - TYPICAL INTERNAL MASONRY CHIMNEY**



Copyright © 2008, IGEM. Licensed copy: IGEM Online Standards. Not to be reproduced.



**FIGURE 16 - EXTERNAL FIREPLACE RECESS AND MASONRY CHIMNEY**

## 8.3 DESIGN OF OPEN FLUE CHIMNEYS

### 8.3.1 General

- 8.3.1.1 Chimney design must comply with the relevant Building Regulations and shall be in accordance with the chimney and appliance manufacturer's instructions and BS 5440-1, as appropriate.

*Note: Chimneys may be either custom built on site using compatible components of masonry or metal or system chimneys supplied as a whole by a single supplier.*

- 8.3.1.2 The chimney route shall be as vertical as is possible with a minimum of bends. Every offset, every bend or obstruction is a resistance to the flow of combustion products in the flue and their inclusion should be avoided where possible.

No part of any natural draught open flue system shall form an angle greater than 45° from the vertical.

- 8.3.1.3 Provision shall be made to support the chimney adequately both in terms of dead weight and lateral support. The dead weight shall not be taken on structural studding and lateral support shall be provided over its entire length in order to accommodate differential movement due to thermal expansion in the flue and drying out shrinkage of the timber. The total movement allowance may be calculated from the sum of (i) the thermal expansion - calculated from the coefficient of linear expansion of the flue material (quoted by the manufacturer) allowing for a nominal temperature of 150°C and (ii) the shrinkage of timber - see A3.5 and A3.6.

- 8.3.1.4 Where a chimney is to be installed on an outside wall, it may be constructed in either the timber frame or in the outer leaf. Any flue blocks shall be insulated to prevent undue heat loss from the building and the formation of condensation in the flue. Where appropriate, they shall be protected by a membrane to prevent damp penetration (see Figure 14).

### 8.3.2 Flue block systems

- 8.3.2.1 New clay gas flue blocks should conform to BS EN 1806 type FB6 and new concrete gas flue blocks should conform to BS EN 1858 type B flue blocks.

Existing gas flue blocks may have been constructed to BS 1289-1 for concrete and BS 1289-2 for clay, but care should be taken to select a compatible appliance, for example a gas fire, that specifies what standard of blocks are suitable for that appliance.

*Note: BS 1289-2:1975 specified a minimum dimension of the flue of 60 mm whereas BS1289-2:1989 specified 90 mm. Not all gas fires are suitable for use with the smaller flue size.*

Alternatively, chimneys designed for use with solid fuel appliances will also be appropriate for gas appliances. Existing chimneys may have been designed as described in BS 6461.

More recently, flue block chimneys will have been specified in accordance with BS EN 1806 for clay blocks or BS EN 1856 for concrete blocks.

- 8.3.2.2 The correct fire recess panel (starter) block or blocks for the selected appliance shall be used together with the appropriate cover block (lintel). The flue opening shall not be less than 610 mm high from the finished hearth surface to the top of the flue opening, nor less than 305 mm wide.

Some appliances may require alternative dimensions and, therefore, the instructions for the intended appliance should be consulted.

- 8.3.2.3 Where a precast gas flue block system is angled, the purpose designed offset block or blocks shall be used. Standard blocks shall not be offset to make a change in direction.
- 8.3.2.4 If the rectangular flue of a flue block system is to be connected to a circular flue of a secondary flue, the appropriate transfer (transition) block shall be used and positioned correctly to ensure that the secondary flue can take the most practicable vertical route to the terminal without any part of the flue being at an angle greater than 45° from the vertical. The chimney shall be adequately supported.
- The secondary flue shall have a minimum diameter of 125 mm and be a twin wall metal chimney to BS EN 1856-1. Single wall metal flue pipe or flexible flue liner shall not be used as a secondary flue above flue block arrangements.
- 8.3.2.5 Flue block chimneys may be designed such that flue blocks are keyed into flanking blocks which space flue blocks from the timber frame. A whole number of the flanking blocks shall have coursing dimensions (when allowing for the thickness of the jointing material as recommended by the manufacturer compatible with the flue blocks.
- 8.3.2.6 When a chimney is designed to be built into a gap between sections of the timber frame, the width of flue blocks, spacer blocks and jointing material as recommended by the manufacturer of the blocks shall fill the gap in the timber frame.
- 8.3.2.7 Any joint between the gas flue blocks shall be filled completely and there shall not be any gap or opening in any part of the chimney except for the gas fire opening and the terminal outlet. Any surplus mortar or jointing compound extruded into the flue shall be cleared from inside each block as the chimney is built and, on completion, the chimney shall be checked to ensure it is free of any debris or restriction.

### 8.3.3 **Metallic chimneys**

- 8.3.3.1 Any new metal chimney shall be of twin wall construction to BS EN 1856-1.

*Note: Existing metal chimneys may have been constructed to BS 715 or an insulated metal chimney system to BS 4543-2 or 3.*

- 8.3.3.2 The chimney shall be supported by non-combustible and corrosion protected wall bands/brackets fitted at not more than 1.8 m intervals throughout its length (including any component in the roof space).
- 8.3.3.3 The connection between a chimney and any ridge vent or terminal shall not be used to provide support for the chimney.
- 8.3.3.4 Any chimney to be used for a gas fire shall not be less than 125 mm nominal internal diameter.
- 8.3.3.5 Any metal flue box shall comply with BS 715.
- 8.3.3.6 A minimum distance of 25 mm must be maintained between any combustible material and the outside of the flue liner in a twin wall metal to BS EN 1856-1 or in accordance with manufacturer's instructions.

### 8.3.4 **Masonry chimneys**

- 8.3.4.1 Any masonry chimney must be designed in accordance with Building Regulations, usually to be constructed in brick or stone work with clay or precast flue liners, or by using factory made flue blocks (see Figures 13-16). Where system chimneys are to be used, they shall be in accordance with BS EN 13063 and BS EN 13069 or BS EN 12446.

*Note: Existing chimneys may have been designed in accordance with BS 6461-1.*

- 8.3.4.2 New chimneys shall use liners in accordance with BS EN 1457 (clay) or BS EN 1857 (concrete).

*Note: A minimum flue size of 200 mm diameter or equivalent area is, usually, recommended for masonry chimney installations.*

### 8.3.5 **Chimneys for gas fires**

Various options for chimneys for gas fires in timber framed buildings are available, including conventional masonry construction.

- 8.3.5.1 An arrangement comprising a flue box and chimney enclosed in a false chimney breast, that can be installed into a new or an existing building, is shown in Figure 12. Where a chimney passes through a floor, there should not be any joint within the floorspace. The manufacturer's instructions and the dimensions quoted in clause 8.3.1 should be followed.

- 8.3.5.2 Any gas flue block system constructed within the internal leaf of the finished timber frame wall shall use blocks which comply with BS EN 1806 (for clay) or BS EN 1858 (for concrete) built as an independent masonry pillar/section to which the timber frames abut (see Figure 13).

- 8.3.5.3 Account shall be taken of the relative movement of the timber frame and masonry pillar, for example by using a vertical channel which locates the blockwork.

- 8.3.5.4 Where it is intended to install a gas fire into a hearth mounting, the base of the fireplace opening should be level with the top of the hearth. Where it is intended to wall mount a fire, then the base of the fireplace opening shall be at least 150 mm above the finished floor level. Gaps that could allow flue products to enter the wall space behind the plasterboard should not be left around the fireplace opening.

- 8.3.5.5 Any gas fire installation must be tested as specified by the manufacturer to ensure that the products of combustion are discharged effectively to atmosphere.

## 8.4 **INSTALLATION OF CHIMNEYS**

### 8.4.1 **General**

Wherever possible, a chimney should be erected in one operation by a single group of operatives. Where this procedure is impracticable, for example pre-cast concrete flue blocks systems involving separate trades, the builder shall ensure that all sections of the complete system are correctly joined.

*Note: The chimney is a single entity which serves the purpose of conducting appliance flue products out of the building and any break in the chimney may cause a hazard.*

#### 8.4.2 **Flue block systems**

8.4.2.1 The flue wall must be fully sealed. Any joint shall be the correct way up and the chimney shall be aligned correctly.

8.4.2.2 Any bonded flue block having a bonding nib shall be keyed into masonry or secured within purpose designed panels (see Figure 13). Alternatively, a non bonded flue block system shall be secured and fixed in accordance with the manufacturer's instructions.

8.4.2.3 If a masonry core wall, which includes flue blocks, is provided between the timber frame walls, for example at step and/or stagger locations, then that wall shall be restrained by the superstructure by corrosion resistant metal ties to one leaf only.

8.4.2.4 Any surplus mortar or jointing compound shall be cleared from inside each block as the chimney is built. The chimney should be protected from falling mortar during construction. The finished internal surface of the flue block shall be smooth and clear of all protrusions of cement and other obstructions. Any jointing compound or mortar shall be cleared from the base of the chimney.

*Note: The smallest obstructions in the chimney, such as mortar protrusions, reduce the free area of the chimney and create more resistance to flow. In some installations, the restriction may be so severe that the chimney is unsuitable for the purpose intended. Such restrictions could render the chimney dangerous and in contravention of GS(I&U)R.*

8.4.2.5 The flue must be fully sealed. There must not be any gap or opening in any part of the chimney except for the appliance opening and the terminal outlet.

#### 8.4.3 **Metal chimneys**

8.4.3.1 Any support band/bracket shall be securely fixed to the chimney and to the building structure but an allowance shall be made for any thermal movement and shrinkage of the timber frame. See Appendix 3 for differential movement allowance.

8.4.3.2 A fire stop plate shall be treated as a support bracket only if so defined by the manufacturer.

#### 8.4.4 **The timber structure**

8.4.4.1 Any route of a chimney shall be designed into the structure and included in the engineering appraisal of the structure. Any framework cutting shall be performed only on the authorisation of the building designer who shall specify details of compensating structure.

8.4.4.2 A chimney shall not interfere with the structural members in the roof space, including permanent wind bracing, or with the plasterboard lining to the roof spandrel frames.

8.4.4.3 A chimney should not pass through a compartment floor or compartment walls in such a manner as to cause an adverse effect on the sound insulation performance or the fire resistance of the floor or wall as required by the relevant Building Regulations.

## **PART 2 - LIGHT STEEL FRAMED BUILDINGS**

Light steel framed buildings have many features in common with timber framed buildings and the same procedures apply to gas installations but the following comments and procedures apply.

### **9 NETWORK PIPELINES AND SERVICE PIPEWORK**

Installation of gas pipework is the same as for timber frame with the following exceptions:

- all gas pipework should be isolated to avoid contact between copper and the galvanised steel frame
- when a pipe passes through a hole in a steel stud, joist, head or base rail, a proprietary grommet should be used to avoid contact between the pipe and the stud
- there is no need to allow for shrinkage or expansion of the frame as this is very small.

### **10 METER INSTALLATIONS**

Installation of a meter installation is the same as for timber frame with the following exceptions:

- under no circumstances should the bottom plate of the wall frame be notched or drilled; and
- where holes are formed to allow gas pipes to pass through the rigid insulation board, such holes should be refilled with a suitable filler material to minimise cold bridging and air leakage.

### **11 INSTALLATION PIPEWORK**

Retro-fitting of gas pipework in the studwork or ceiling voids of steel framed properties is not recommended, as materials used to board the floors generally contribute towards the structural integrity of the building. Note that pipework must not be fitted into a duct or void unless it is ventilated in accordance with >Clause 6.2.2<. Where surface fixing of pipework is not allowable, consultation with the design engineer is recommended.

Work must comply with the building regulations for England and Wales, and Scotland, as appropriate.

Copper pipework shall be electrically isolated from steel frames to prevent galvanic corrosion.

### **12 APPLIANCES**

Appliance installation requirements are similar to those for timber frame with the following comments:

- load bearing light steel frame walls are, normally, constructed using one or two layers of 12.5 mm fireline plasterboard as the internal lining material. Due to the non-combustibility of this wall surface finish, appliance manufacturers' data should be consulted to ensure the unit is suitable for fixing back to plasterboard.
- when cutting holes through the rigid urethane insulation board for the passage of the room sealed chimney system, any gaps should be made good with a non-combustible filler material, for example mineral wool.

When supporting an appliance:

- self-drilling and tapping fixings are most commonly used to securely fix appliances to walls when a strap has been installed
- when purpose designed supports have been fitted by the builder, in the majority of cases and prior to plasterboarding, metal straps will have been fitted to the steel frame where the appliance is to be fitted so that a “good” fixing can be achieved
- in an existing building;
  - replacement of heating appliances needs careful consideration so that the new chimney position does not clash with any structural bracing in the steel frame. To minimise this risk, it is recommended that any “new” appliance use the existing hole left by the original chimney
  - fixing of the new appliance onto the wall can be undertaken using a number of proprietary fixings, however, for the best results, the new appliance should be attached via the metal strapping which should have been installed to reinforce the plasterboard.

## APPENDIX 1 : GLOSSARY, ACRONYMS, ABBREVIATIONS, SYMBOLS AND UNITS

### A1.1 GLOSSARY

See also Sub-Section 8.2 for terms and definitions relating to chimneys.

<b>additional emergency control valve (AECV)</b>	As defined in IGE/G/1.
<b>breather membrane</b>	A sheet membrane that is waterproof but permeable to water vapour. Early types were predominantly paper based but woven plastic based materials are now more common. Its function is to protect and waterproof the building prior to cladding being completed and to provide a second line of defence against any wind driven rain which may penetrate the cladding.
<b>cavity</b>	A drained and ventilated, or vented, space between the external cladding and the face of the timber wall panel. The meaning of ventilated and vented is as defined in BS 5250.
<b>emergency control valve (ECV)</b>	The ECV is a valve, not being an "additional emergency control valve" (AECV) for shutting off the supply of gas in an emergency, intended for use by a consumer of gas and being installed at the end of a service or distribution main. The outlet of the ECV terminates, and thus defines, the end of the Network.  <i>Note: The gas conveyor (which is, normally, a GT) has to agree the designation of the ECV which defines the end of the Network. For all "recommended gas supply arrangements" (see IGE/G/1), the ECV will be upstream of all components of the meter installation.</i>
<b>external cladding</b>	The outer face of the wall. It may be masonry tied to the timber structure with special flexible ties or it may be a lightweight cladding such as hung tiles, timber or cement render on mesh which is fixed directly to the timber wall panel.
<b>gas transporter (GT)</b>	A company, licensed by OFGEM, that operates a Network which transports gas in accordance with the "Network Code".
<b>inlet isolation valve (IIV)</b>	As defined in IGE/G/5.
<b>installation pipework</b>	Any pipework or fitting from the outlet of the meter installation to points at which appliances/equipment are to be connected. It does not mean: <ul style="list-style-type: none"> <li>• a service (pipe) or distribution main or other pipeline</li> <li>• a pipe or fitting comprised in a gas appliance</li> <li>• a pipe or fitting within a meter installation</li> <li>• any valve attached to a storage container or cylinder.</li> </ul>
<b>intermediate floor panels</b>	Timber floor usually located on and supported by the timber frame wall.
<b>light steel frame</b>	Frame structures constructed from cold-rolled galvanised steel with a typical thickness of 1.6 mm (which may vary from 1.2 mm to 3.2 mm).



**meter installation**

A meter installation includes a primary meter and any associated volume conversion system, valve, filter, meter regulator or PRI, flexible connection, meter by-pass, interconnecting pipework, fitting and support.

A meter installation commences at either:

- the outlet of the first common valve through which all the gas entering the meter installation will pass and which is upstream of the first meter regulator/PRI (including any filtration) upstream of the meter or,
- in the case of a meter upstream of a regulator/PRI, or of an unregulated supply, the outlet flange of the first common valve upstream of the primary filter(s) for the meter installation.

A meter installation terminates at either:

- the outlet connection of the meter (if a meter outlet valve (MOV) is not fitted) or,
- the outlet of the meter outlet adaptor if fitted or,
- the outlet of the MOV (or outlet spool) if fitted or,
- the outlet of the tee fitted downstream of the meter where a meter by-pass rejoins the pipework on the outlet of the meter or,
- in the case of a meter upstream of a regulator/PRI, the outlet of the regulator/PRI outlet valve (PRIOV) or spool piece for a regulator by-pass or, where a twin stream regulator/PRI is installed, the outlet of the tee where the two streams join or,
- if provided, the outlet of the meter installation outlet valve (MIOV) or,
- in the case of a semi-concealed domestic meter with a flexible connection downstream of the meter, the outlet of the meter box outlet adaptor,

whichever is appropriate for the system.

**Network**

The Network comprises interconnecting pipes which are downstream of a gas reception terminal, processing facility, storage facility or importing interconnector, and used for the conveyance of gas to consumers as defined in GS(M)R.

*Note: A "network" is part of the "Network".*

**noggings**

Horizontal timber rails fitted between studs in the wall panels to provide fixing points.

**party wall**

Wall between two adjoining dwellings or occupancies. It is required to have at least 1 hour fire resistance which can be achieved by the use of multiple plasterboard layers. In dwellings, the wall also needs proven sound reduction performance. "Party wall" is referred to in the Building Regulations as a compartment wall and in the Building Regulations (Scotland) as a separating wall.

**pipeline isolation valve (PIV)**

As defined in IGE/G/1.

**primary meter**

A gas meter, the index reading of which constitutes the basis of charge for all gas supplied through that meter.

*Note: This definition is a variation of the legal definition taken from GS(I&U)R.*

<b>pressure regulating installation (PRI)</b>	An assembly of equipment designed to regulate, or reduce, the pressure of gas. A PRI comprises all pressure-containing and associated equipment between the upstream face of the PRIIV and the downstream face of the PRIOV.
<b>utility infrastructure provider (UIP)</b>	A company which designs and installs gas mains and services on behalf of a developer for adoption by a GT. They may also install other utilities, for example water, electricity, etc.
<b>service pipe</b>	A network pipe for conveying Natural Gas to premises from a distribution main, being any pipe between a distribution main and the outlet of the ECV.
<b>service pipework</b>	<i>Note: The service (pipe) is, normally, owned by or is the responsibility of a GT.</i> A pipe for distributing gas, for example LPG, to premises from a storage vessel to the outlet of an ECV.
<b>sole plate</b>	Generally, the first timber component to be fixed, the sole plate is fixed to the substructure over a dpc and thus forms the base upon which the timber structure is erected. A sole plate is not always used. When it is omitted, the bottom rail of the wall panel has to fulfil the same function.
<b>structural wall</b>	Timber frame panels with timber studs at 400 mm or 600 mm nominal centres and a sheathing of plywood or a similar wood-based board. Insulation (usually mineral wool) is fitted within each panel. In the past, this may have been 25 mm or 50 mm thickness but currently, it is normal to fill the panel thickness. The inner face comprises a VCL and, usually, a plasterboard lining.
<b>vapour control layer (VCL)</b>	A membrane fixed to the stud framing, which increases the vapour resistance of the internal wall face to reduce the transmission of water vapour into the wall panel. It may be a separate polythene sheet, but it can also be an integral part of the plasterboard lining in the form of a polythene or metallized plastic sheet pre-bonded to the back of the plasterboard.

## A1.2 ACRONYMS AND ABBREVIATIONS

<b>ACoP</b>	Approved Code of Practice.
<b>ACS</b>	Accredited Certification Scheme.
<b>AD</b>	Approved Document.
<b>AECV</b>	Additional emergency control valve.
<b>AIGT</b>	Association of Independent Gas Transporters.
<b>BFCMA</b>	British Flue and Chimney Manufacturers Association.
<b>CDM</b>	Construction (Design and Management) Regulations.
<b>CHSWR</b>	Construction (Health, Safety and Welfare) Regulations.
<b>CORGI</b>	Council for Registered Gas Installers.
<b>CP</b>	Cathodic protection.
<b>CSST</b>	Corrugated stainless steel tube.
<b>CV</b>	Calorific value.
<b>DSEAR</b>	Dangerous Substances and Explosive Atmospheres Regulations.
<b>ECV</b>	Emergency control valve.
<b>GS(I&amp;U)R</b>	Gas Safety (Installation and Use) Regulations
<b>GS(M)R</b>	Gas Safety (Management Regulations)
<b>GT</b>	Gas transporter.
<b>HBF</b>	House Builders Federation.
<b>HSE</b>	Health and Safety Executive.
<b>HSWA</b>	Health and Safety at Work etc. Act.
<b>IGEM</b>	Institution of Gas Engineers and Managers.
<b>IIV</b>	Inlet isolation valve.
<b>LPG</b>	Liquefied petroleum gas.
<b>MAM</b>	Meter asset manager.

<b>MHSWR</b>	Management of Health and Safety at Work Regulations.
<b>MIOV</b>	Meter installation outlet valve.
<b>MOP</b>	Maximum operating pressure.
<b>MOV</b>	Meter outlet valve.
<b>NHBC</b>	National House Building Council.
<b>OP</b>	Operating pressure.
<b>PE</b>	Polyethylene.
<b>PIV</b>	Pipeline isolation valve
<b>PRI</b>	Pressure regulating installation.
<b>PRIIV</b>	PRI inlet valve.
<b>PSR</b>	Pipeline Safety Regulations.
<b>PRIOV</b>	PRI outlet valve.
<b>SBGI</b>	SBGI (formerly known as the Society of British Gas Industries).
<b>SBSA</b>	Scottish Building Standards Agency.
<b>UIP</b>	Utility infrastructure provider.
<b>UKAS</b>	United Kingdom Accreditation Service.
<b>UKTFA</b>	United Kingdom Timber Frame Association
<b>VCL</b>	Vapour control layer.

A1.3

**UNITS**

<b>kg</b>	kilogrammes
<b>kW</b>	kilowatts
<b>m</b>	metre
<b>mbar</b>	millibar
<b>mm</b>	millimetre
<b>m<sup>2</sup></b>	square metres
<b>°C</b>	degrees Celsius.

## APPENDIX 2 : REFERENCES

The Appendix lists all legislation, Standards, Codes of Practice and related Procedures and Recommendations mentioned in this document. Care should be taken to ensure that the current edition of the document is used.

Where British, European or International Standards are quoted, equivalent Standards may be equally appropriate.

### A2.1 **LEGISLATION**

- Building Regulations (As Amended) 2002 for England and Wales
- Building (Scotland) Regulations 2004
- Building Regulations (Northern Ireland) 2000, No. 289
- Building Regulations 2003: Isle of Man Government Statutory Document No. 829/03
- Construction (Design and Management) Regulations 1994
- Construction (Health, Safety and Welfare Regulations) 1996
- Dangerous Substances and Explosive Atmospheres Regulations 2002
- Electricity at Work Regulations 1989 and Memorandum of Guidance 1958
- Health and Safety at Work etc. Act 1974
- Gas Appliances (Safety) Regulations 1995
- Gas Safety (Installation and Use) Regulations 1998
- Gas Safety (Management) Regulations 1996
- Management of Health and Safety at Work Regulations 1999
- Pipeline Safety Regulations 1996.

### A2.2 **HSE AcoPs and GUIDANCE**

- HS(G)48 Human factors in industrial safety. Guidance
- HS(L)25 Personal Protective Equipment at Work Regulations 1992. Guidance
- HS(L)56 Safety in the Installation and Use of Gas Systems and Appliances. ACoP and Guidance
- HS(L)80 A Guide to the Gas Safety (Management) Regulations 1996. Guidance
- HS(L)82 A guide to the Pipelines Safety Regulations 1996.
- HS(R)25. Electricity at Work Regulations. Guidance.
- HSC COP 20 Standards of training in safe gas operation.

### A2.3 **BRITISH STANDARDS** (abbreviated titles)

- BS 476 Parts 20-24 Fire tests on building materials and structures
- BS 6461-1 Chimneys and flues for domestic appliances
- BS 715 Sheet metal flue boxes for gas fired appliances
- BS 1289 Flue blocks and masonry terminals (obsolete)
- BS 4543-2, 3 Factory-made insulated chimneys
- BS 5250 Control of condensation
- BS 5440 -1 Installation and maintenance of flues and ventilation for gas appliances. Flues
- BS 5440-2 Installation and maintenance of flues and ventilation for gas appliances. Ventilation
- BS 5482-1 Code of Practice for domestic butane and propane gas installations in permanent dwellings

- BS 5871 Installation of gas fires, convector heaters, fire/back boiler and DFEs
- BS 6400-1 Domestic sized meter installations – low pressure Natural Gas
- BS 6400-2 Domestic sized meter installations – medium pressure Natural Gas.
- BS 6461 Installation of chimneys and flues (obsolete)
- BS 6798 Installation of gas-fired boilers of rated input not exceeding 70 kW net
- BS 6891 Low pressure gas pipework (domestic premises)
- BS 7671 Electrical installations (the IEE wiring regulations)
- BS EN 473 Qualification and certification of NDT personnel
- BS EN 1443 Chimneys – general requirements
- BS EN 1457 Chimneys - clay/ceramic flue liners
- BS EN 1806 Chimneys - clay/ceramic flue blocks for single wall chimneys
- BS EN 1856 Chimneys – requirements for metal chimneys –
  - -1 System chimney products
  - -2 Metal liners and connecting flue pipes
- BS EN 1857 Chimney – components - concrete flue liners
- BS EN 1858 Chimney – components - Concrete flue blocks
- BS EN 12446 Chimneys – concrete outer wall elements
- BS EN 13063 System chimneys with clay/ceramic flue liners
- BS EN 13069 Clay/ceramic outer walls for system chimneys
- BS EN 13384 Chimneys – Thermal and fluid dynamic calculation methods.

A2.4

**IGEM** ([www.igem.org.uk](http://www.igem.org.uk))

- IGE/UP/1 Edition 2 RWA Strength testing, tightness testing and direct purging of industrial and commercial gas installations
- IGE/UP/1A Edition 2 RWA Strength testing, tightness testing and direct purging of small low pressure industrial and commercial Natural gas installations
- IGE/UP/1B Edition 2 Tightness testing and direct purging of small Natural Gas installations
- >IGEM/UP/2 Edition 2 Gas installation pipework on industrial and commercial premises<
- IGE/TD/3 Edition 4 Steel and PE pipelines for gas distribution
- IGE/TD/4 Edition 4 PE and steel gas services  
*Note: Publication anticipated in 2006. Use Edition 3 until published.*
- IGE/TD/13 Pressure regulating installations for transmission and distribution systems
- IGE/TD/101 Management of UIP activities
- IGE/GM/6 Specification for low pressure diaphragm and rotary displacement meter installations with badged meter capacities exceeding 6 m<sup>3</sup>/h (212 ft<sup>3</sup>/h) but not exceeding 1076 m<sup>3</sup>/h (38000 ft<sup>3</sup>/h)
- IGE/GM/8 Non-domestic meter installations. Flow rate exceeding 6 m<sup>3</sup> h<sup>-1</sup> and inlet pressure not exceeding 38 bar

- IGE/G/1 Defining the end of the Network, a meter installation and installation pipework
- IGE/G/5 Gas in flats and other multi-dwelling buildings.

A2.5

**MISCELLANEOUS**

- Approved Documents to the Building Regulations 2001 for England and Wales
- Robust details and accredited construction details which comply with Approved Documents E and L respectively for England and Wales - Robust Details Ltd.
- Timber Frame Construction - Timber Research & Development Association.
- Multi-storey Timber Frame Buildings - BRE / TRADA
- Timber Frame Builders Pack - UK Timber Frame Association
- Timber Frame Technical Pack - UK Timber Frame Association
- Technical Guidance Notes - UK Timber Frame Association
- Principles of Timber Framed Construction - The Nordic Timber Council
- Timber Frame with Confidence - British Woodworking Federation
- NHBC Standards - Chapter 6.2
- IEE Electrician's Guide to the Building Regulations.

## **APPENDIX 3 : TIMBER FRAME CONSTRUCTION**

### **A3.1 RECOGNITION OF EXISTING TIMBER FRAME CONSTRUCTION**

For an existing building, it may not be easy to recognise whether or not it is of the timber frame type. However, before installation, the type of construction can be determined to plan for the provision of any special materials and procedures.

The following details may assist in recognition:

- the name of the builder or building control body - who may be able to provide construction information
- the owner of the building - who may be aware of the type of construction
- on a housing estate, the structure of surrounding buildings
- the wall construction type (by tapping). However, this may be insufficient as dry lined masonry walls give the same result as timber frame walls
- identifying the compartment or external wall in the loft space.

### **A3.2 TYPICAL CONSTRUCTION**

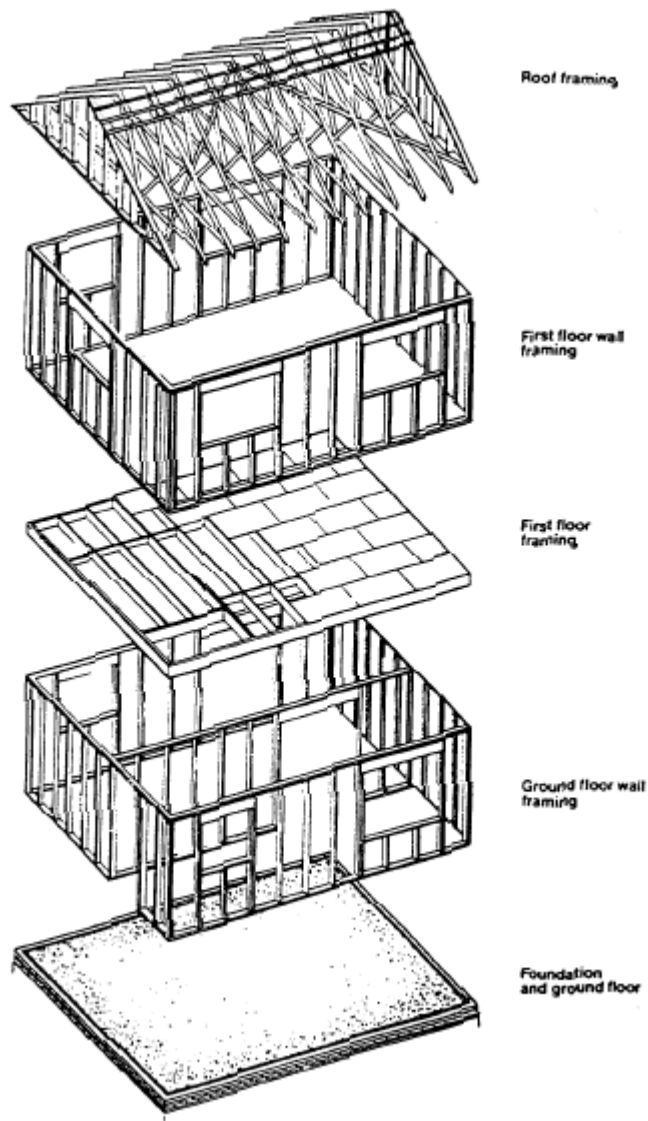
The main difference between timber frame and masonry cavity wall construction relates to the use of structural timber framed external, internal and compartment walls. The floor and roof construction are similar to other types of construction although the floors may act as diaphragms to provide structural stiffness.

The majority of timber frame construction at the present time is houses or flats but it is also used for buildings such as hotels, residential homes, and offices. Buildings up to six storeys in height have been constructed. The number of storeys is likely to be limited by fire restraints in the building regulations of the appropriate legislative authority.

Timber frame construction in the UK, generally, uses what is described as platform construction. This means that each successive floor is constructed as a platform on top of the walls beneath and the walls panels for the upper storey are erected from the platform floor. A typical structure is shown in Figure 17. All structural loads are carried by the timber frame. The main function of the external cladding is to weatherproof the building although brick cladding may contribute to the structural strength. A typical sequence of construction might be as follows.

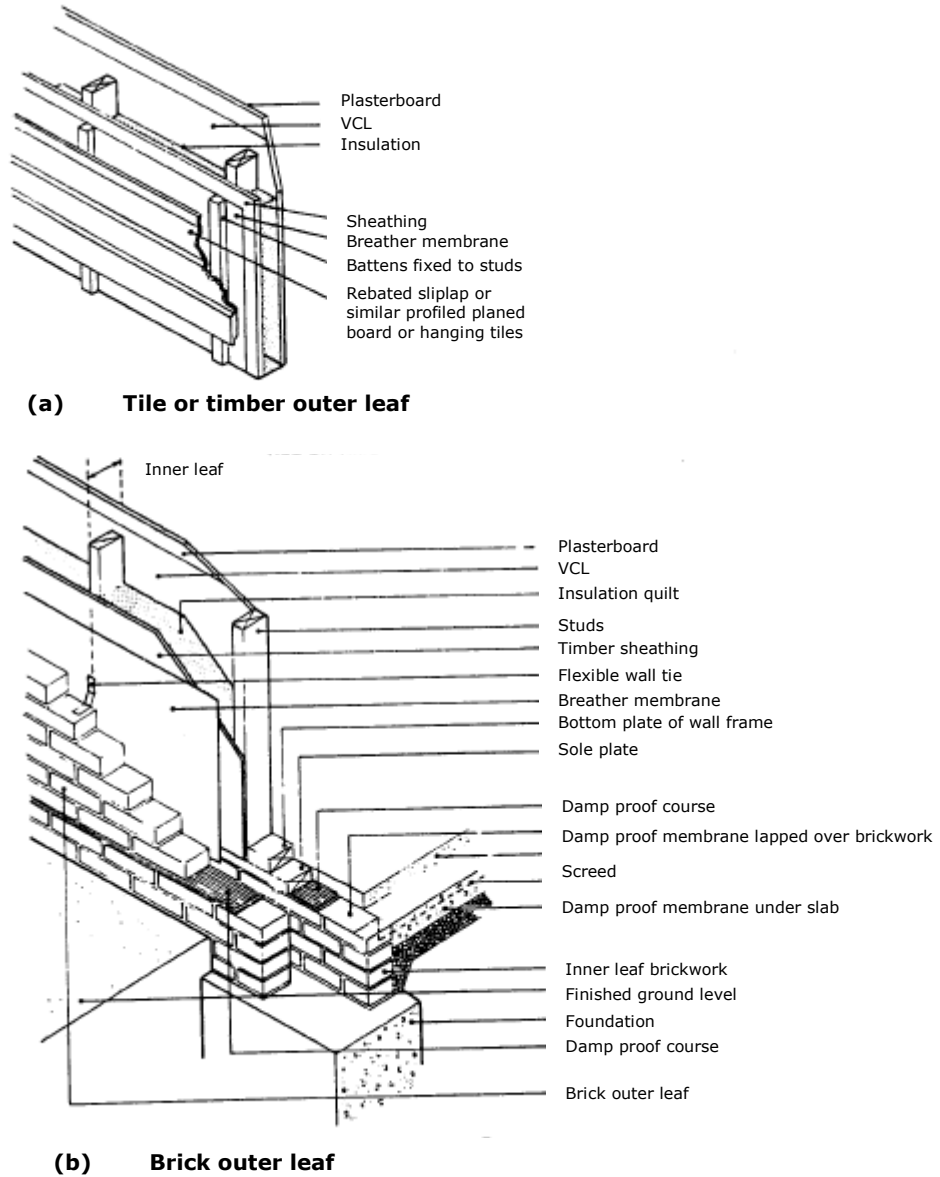
Foundations can be conventional such as strip foundations, trench fill or a reinforced concrete raft. The ground floor may be insitu concrete, precast concrete beam and block, or it may be site constructed or prefabricated using timber joists. The timber components are, usually, prefabricated and may be manhandled into place or crane erected depending upon their size. Timber wall panels consist of timber stud framing with a plywood or similar woodbased board sheathing, usually, but not always, on the outer face of the panels (see Figure 18). Window openings are preformed in the panels, insulation is fitted between the studs and the internal lining is, usually, gypsum plasterboard. Insulation and plasterboard are, generally, site fixed but can also be prefixed in the factory. Intermediate floors are of timber joists, either site assembled or supplied as prefabricated panels. Roofs may be of trusses or trussed rafters, flat roof joists or site built "cut" roofs.

The stud framework for the wall panels is typically at 600mm centres, but may also be at either 300 mm, 400 mm or 600 mm centres. The timber size is commonly 90 x 38 mm, although 96 x 47 mm and 140 x 38 mm timbers are also used.



**FIGURE 17 - TYPICAL TIMBER FRAME CONSTRUCTION USING THE PLATFORM FRAME METHOD**





**FIGURE 18 - TYPICAL CONSTRUCTIONAL DETAILS**

**A3.3 SEQUENCE OF WORK**

Because it uses prefabricated components, timber frame construction is, generally, built more quickly than other types of construction. It is common for a two storey house to be erected from a prepared slab or foundation to dry shell stage i.e. the timber frame erected and made weathertight but without the external cladding, in one day if a crane and large panels are used, or three days if smaller manhandled panels are used. Typical construction times are, usually, less than for masonry construction.

Work on services can start as soon as the dry shell stage is reached, while the external cladding is constructed or fixed and, usually, before the wall insulation and internal lining is fitted. When these are pre-fixed in the factory, specific provision for services is made as part of the design. Where pipework is surface run, it will be done after the plasterboard lining is fixed and care is necessary to obtain suitable fixings and not to cause damage to any other services which have been concealed within the wall thickness.

**A3.4 NOTCHING AND DRILLING OF TIMBER COMPONENTS**

Figures 20 and 21 show the allowable size and location of notches and holes in solid timber joists and wall studs. Wall studs are not to be notched. Where horizontal service runs are necessary, holes need to be drilled as near as possible to the centre line of the timber member.

Where engineered I-joists are used, the top and bottom flanges are not to be drilled, notched altered or damaged (see Section 6). Roof rafters, purlins, trussed rafters, bracing etc should never be notched, drilled or cut away without the approval of the structural engineer.

Gas and water pipes are not to be run in external wall panels where the cold pipe could act as a condenser to water vapour within the panel, creating dampness which would be trapped and could cause decay. Pipework on external walls needs to be surface mounted or be fitted within suitable service ducts on the warm side of the VCL (see Figure 5).

**A3.5 DIFFERENTIAL MOVEMENT ON TIMBER FRAME BUILDINGS (PLATFORM CONSTRUCTION)**

In addition to compression of the timber components that occurs during construction, most timber frame buildings will dry out to release the excess moisture contained in the timber members and dependant upon the type of timber used the shrinkage will vary. Principal shrinkage occurs in the vertical plain at cross grain section and mostly at floor zones. Because of this, the timber leaf of the walls will move downwards and, thus, if any component bridges across the cavity between the timber frame and the masonry cladding, provision has to be made to account for such movement. This needs to be allowed for at components in external walls such as windows/doors/pipework/horizontal room sealed chimney systems, etc.

The same differential movements would apply where service or installation risers pass through a timber frame structure. However, on a timber frame building where the cladding is fixed to the timber frame, i.e. tile boarding, hanging etc., a provision for differential movement will not be necessary since the cladding and anything passing through the cladding and timber frame will move together.

For the purpose of design two examples are shown (see Figure 19) using ordinary joist and engineered wood products (I joists). This is based on the TRADA/BRE document headed "Multi-storey timber frame buildings".

A3.6 **CALCULATION OF DIFFERENTIAL MOVEMENT ON TIMBER FRAMED BUILDINGS (BASED ON TF 2000 FORMULA)**

In order to calculate the relative shrinkage of a timber frame leaf relative to a masonry wall after both have settled due to their respective loads, the building designer should be consulted, especially if the construction method and or number/size of horizontal timbers vary from that shown below.

The illustration (Figure 19) shows a typical timber framed building up to 6 storeys. A timber frame building up to 4 storeys high can be constructed using solid wood joists or engineered wood products, but it is unlikely that anything higher would be in joists other than engineered wood products (I joists). The shrinkage values for both these alternatives are shown in the table below and are based on BRE/TRADA TF2000 building tests.

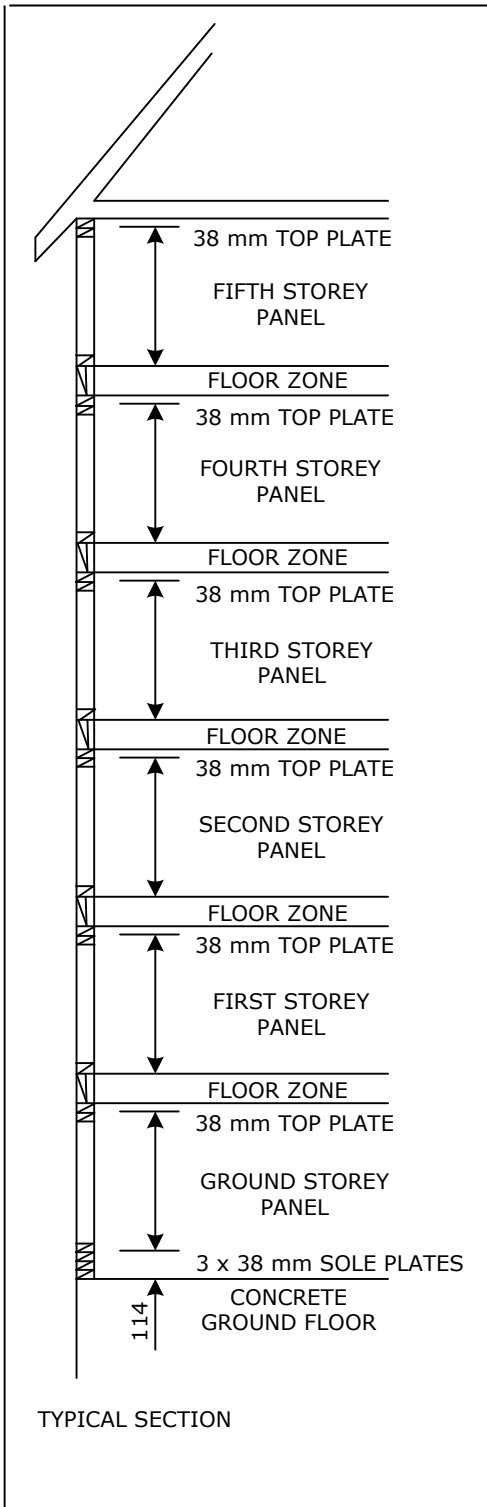
Cavity bridging features, for example room sealed chimney systems, air vents, pipes, etc., need to be installed in such a way that allows for this movement. For example, a room sealed chimney system can be installed with a 5 mm gap below it in the outer leaf on the ground floor. The terminal flange will, usually, conceal this, but the gap needs making good with mastic to prevent rain penetration.

A3.7 **THERMAL IMPLICATIONS**

Timber frame construction has two characteristics which are different from brick and block construction and which can affect the design and efficiency of the heating installation:

- the structures have minimal mass which means they will warm up and cool down relatively quickly compared to older masonry buildings
- a timber framed building is likely to be more air tight than most other types of construction, reducing heat loss due to excessive air change rates.

By careful choice of an appropriate system, for example a suitably sized warm air or a low capacity quick response wet central heating system with high part load efficiency and the appropriate control system, it is possible to reduce both installation costs and running costs for users.



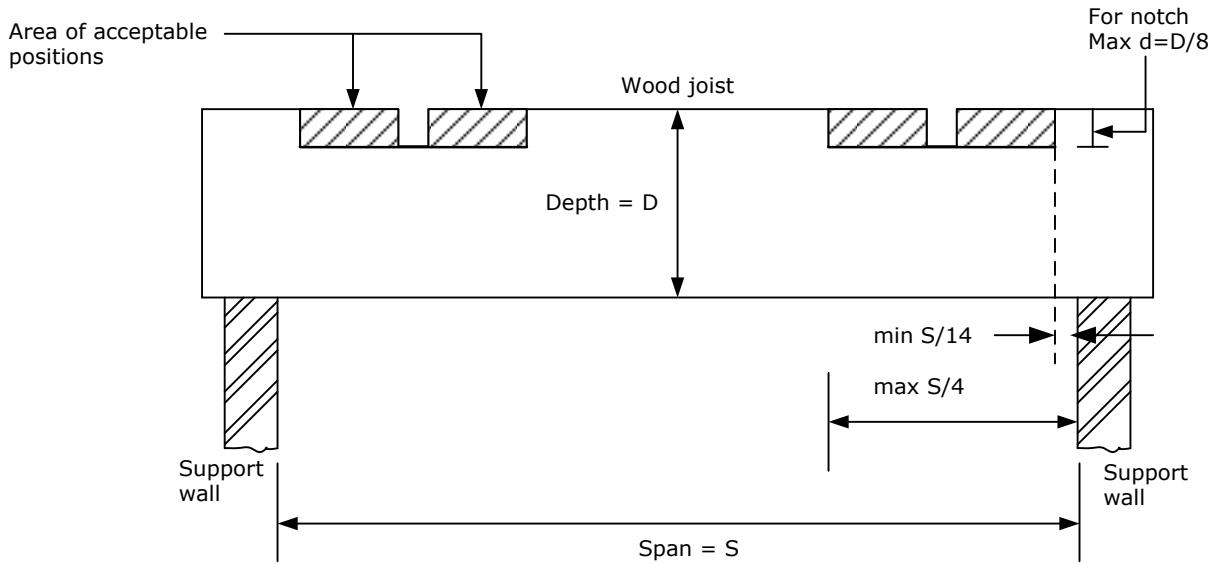
Typical Shrinkage based on TF2000 formula*		
Wall panel on storey level	Wall panel using 220 mm deep solid joists with 20% moisture content	Wall panel using engineered wood products 240 mm deep with 12% moisture content or below
Ground	5	5
1st	14	10
2 <sup>nd</sup>	23	14
3 <sup>rd</sup>	32	20
4 <sup>th</sup>	41	26
5 <sup>th</sup>	51	31

- solid joists 220 mm deep with timber at 20% moisture content, 1.40 mm / 50 mm cross grained timber,
- engineered wood products (I joists) 240 mm deep at 12% moisture content or below, 0.40 mm / 50 mm cross grained timber,
- ground floor is concrete and building 3 X 38 mm sole plates = 114 mm.

Note: Assuming common timber frame building practice. If the ground floor, the sole plates or the type of joists vary, seek direction from the main contractor or designer since the dimensions given for shrinkage in the scheme will vary.

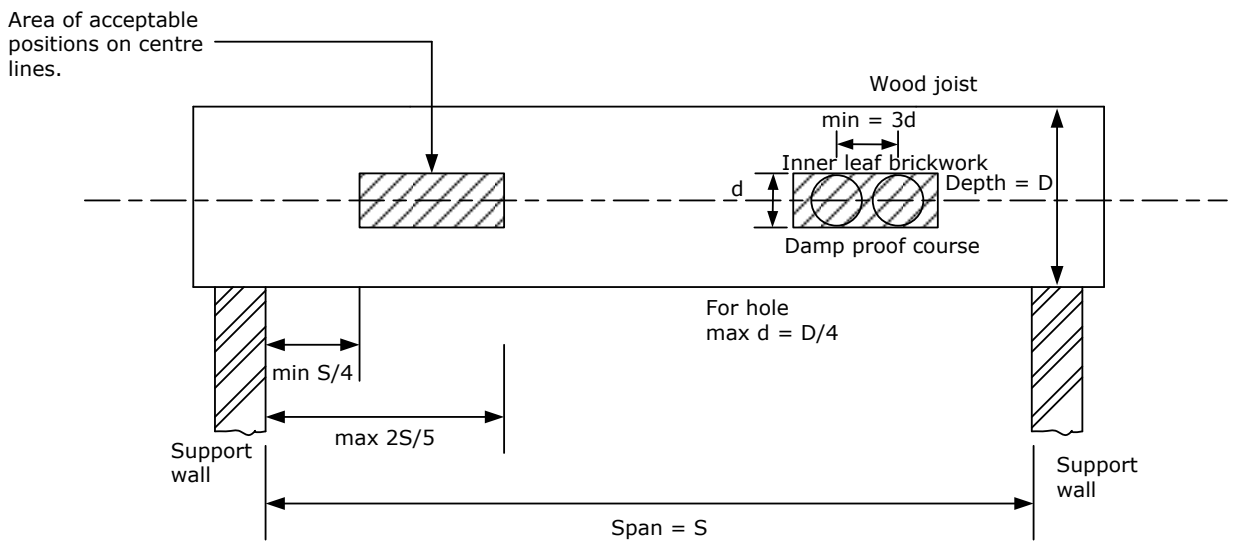
\* TF2000 building tests by BRE/TRADA (Building Research Establishment/Timber Research and Development Association) on a six storey building.

**FIGURE 19 - TYPICAL SHRINKAGE BASED ON TF 2000 FORMULA**



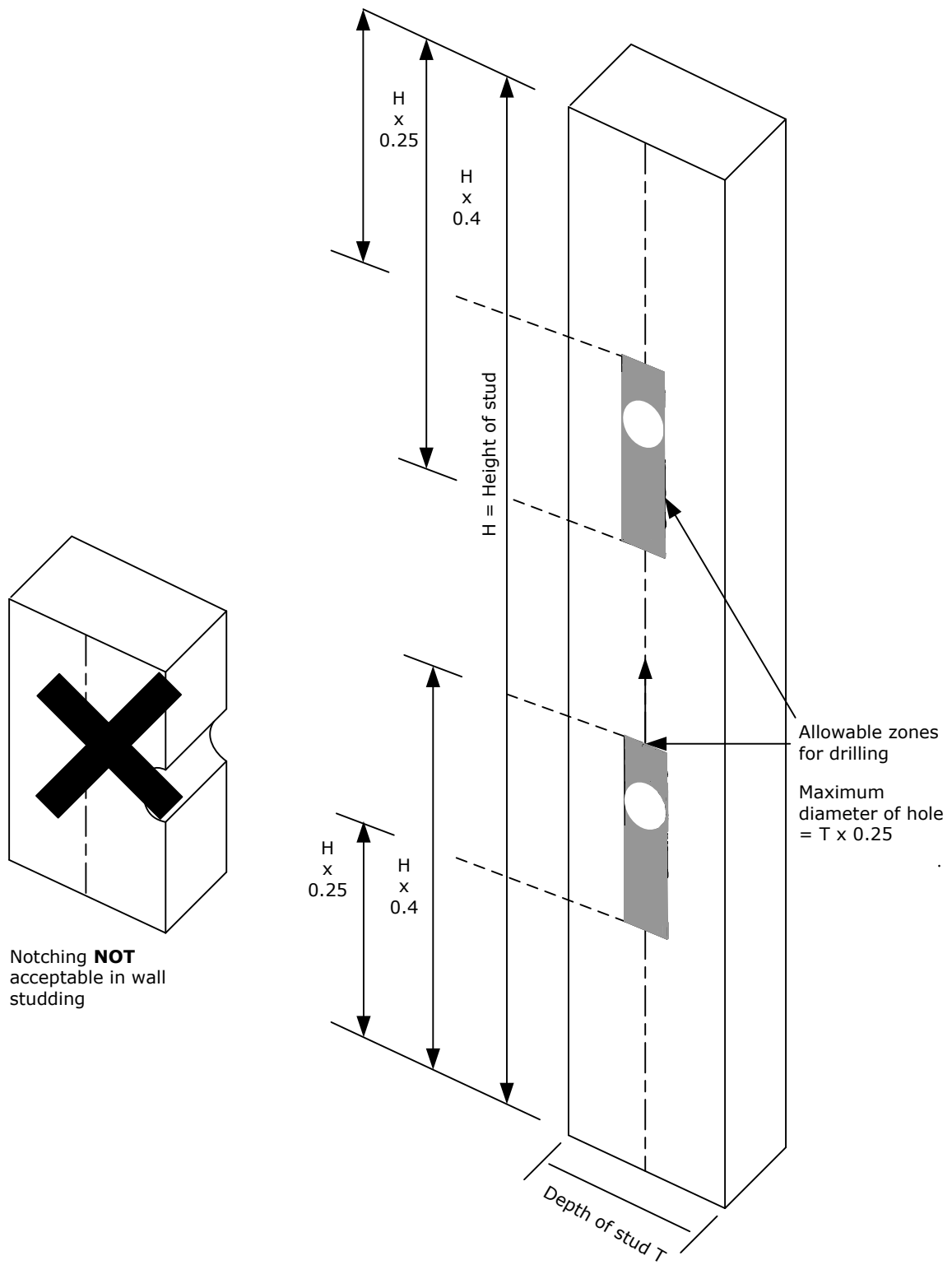
Note: Notches should have rounded corners and must not extend across the joint between floorboards

**(a) Solid timber joist notching.**



**(b) Solid timber joist drilling**

**FIGURE 20 - ALLOWABLE SIZE AND LOCATION OF NOTCHES AND HOLES IN SOLID TIMBER JOISTS**



**FIGURE 21 - ALLOWABLE SIZE AND LOCATION OF HOLES IN WALL STUDDING**

## **APPENDIX 4 : LIGHT STEEL FRAME CONSTRUCTION**

### **A4.1 AN OVERVIEW**

Light steel framed houses are a relatively new form of construction to the UK housing stock, though in other countries this type of construction has been in abundance for many years. The first light steel frame house in the UK was constructed in the early 1980s and at the time of publication of this document, it is estimated that there are in excess of 2,500 houses in the UK constructed in this manner.

Light steel frame construction replaces the internal leaf of blockwork of traditionally built masonry properties or the timber framing of a timber frame construction. The external leaf can be constructed with a multitude of materials depending on the architect/developer's specification. As with timber frame construction, the floor boarding will work with the floor joists to provide a diaphragm to resist lateral loads. When clad with masonry, a light steel frame structure is virtually identical in appearance to a traditionally built masonry property. With present light steel build methods, buildings up to 9 storeys have been built.

Light steel frame uses platform construction principles where successive floors pass the loads to the foundations. The external finish of the building is purely a weatherproofing layer, but also assists in the thermal performance of the building.

The panels for light steel frame are, typically man-handled into position and joined together using self-tapping screws and/or bolts. Where the size of panel exceeds safe manual handling limits, mechanical handling can be used. Floor cassettes are positioned onto the top of the steel frames and screwed down. Subsequent wall panels and floor cassettes are then installed, as required.

Once the main frame is erected, rigid insulation board is fixed to the external face of the frame to give the desired U value. This ensures that the inner leaf becomes a "warm wall" and, thus, minimises any corrosion of the metal frames. The rigid insulation board has a built-in metallic lining so any joints between insulation boards are taped with foil tape. The internal face of the frame is fitted with one or two layers of 12.5 mm fireline plasterboard to give 30 minutes or 60 minutes of fire protection as required. In certain cases, alternative materials to plasterboard may be used to assist the frame's fire performance.

Studwork for the panels is pre-galvanised steel, generally at 600 mm centres, although 300 and 400 mm centres can be used. Stud dimensions are commonly 75 x 42 mm for buildings up to 4 storeys, while on buildings above this 100 x 50 studs are used.

Once erected, there is minimal movement in light steel framed properties, which means that any cavity bridging feature such as pipes, vents or chimney systems may be installed without any allowance for shrinkage of the frame.

Pipework may be installed readily, but any metal pipework has to be isolated from the steel frame – this is, normally, achieved via plastic isolating grommets and spacers.

Installations for any services can only use the factory drilled holes in the frames and floor cassettes. If any additional holes are required, consultation with the design engineer is required.



**FIGURE 22 - STEEL FRAMES. C SECTIONED STEEL STUDS WITH FLAT DIAGONAL STRAPPING ON OUTER SURFACE**



**FIGURE 23 - STEEL FRAMES ASSEMBLED TOGETHER**





**FIGURE 24 - "I" JOISTS WITH SWAGED HOLES TO ACCOMMODATE NON-GAS SERVICES**



**FIGURE 25 - LATTICE WEBBED "I" JOISTS**

Copyright © 2008, IGEM. Licensed copy: IGEM Online Standards. Not to be reproduced.

## **APPENDIX 5 : SUPPORTING AN APPLIANCE IN AN EXISTING TIMBER FRAMED BUILDING**

The following methods can be used to support an appliance in an existing building i.e. where the builder has not catered for a gas appliance installation.

### **A5.1 SCREWED INTO STUDS**

The weight of the appliance is taken by structural components of the building. Normal wood screws may be used taking care to ensure that all fixings are located into the studs, thus providing adequate support for the weight of the appliance.

When it is not possible to screw all of the fixings into the timber studs at all the fixing points, as many points as possible can be affixed with screws into the timber and the remaining points may be fastened to the plasterboard using the appropriate cavity fixings (see Figure 26).

### **A5.2 SCREWED INTO NOGGINGS BEHIND THE PLASTERBOARD**

If the weight of the appliance is to be transferred via the noggings to the studs, this method will demand removal of a section of plasterboard, VCL and insulation, so that the noggings can be nailed or screwed in place to correspond to the appliance fixing positions. The insulation, VCL and plasterboard then need to be replaced to the same standard as before with special care being taken to replace fixings at centres not exceeding 150 mm. As above, normal wood screws can be used to support the appliance, taking care to ensure that the noggings are securely fitted to take the weight of the appliance.

### **A5.3 FIXED TO A NON-COMBUSTIBLE SHEET MOUNTED IN FRONT OF PLASTERBOARD**

This sheet may be fixed to the surface of the plasterboard but need not extend sideways beyond the appliance.

It needs to be of a rigid material such as 12.5 mm thick fibre cement board. It may be screwed to the timber studs if the geometry of the appliance and the selected location permit. Alternatively, it may be attached to the plasterboard using proprietary cavity fixings. The appliance is then mounted on the non-combustible sheet and plasterboard using proprietary cavity fixings.

12.5 mm fibre cement or similar board may also serve purposes other than appliance support, for example covering the end of the 25 mm gap around the chimney system, covering the breach in the plasterboard surface around the sleeve and making up the remainder of the 25 mm of non-combustible material between appliance and timber when mounting an appliance where the manufacturer's instructions state the appliance to be unsuitable for mounting on combustible walls.

### **A5.4 MOUNTED ON THE PLASTERBOARD WALL USING PROPRIETARY LOAD SPREADING FIXINGS**

This method is not recommended except for very lightweight appliances. Consult both the appliance and plasterboard manufacturer.

Note: *Fixings correctly installed in new plasterboard can support large weights (typically up to 20 kg per fixing). However, when the plasterboard is heated above 50 °C, it dehydrates and the strength diminishes. For example, this will occur when the temperature is raised by 30 °C above an ambient temperature of 20 °C. Unless the appliance manufacturer's instructions say otherwise, it is to be assumed that this dehydration will occur.*

The strength of plasterboard can be substantially increased by the simple

expedient of adding reinforcing material such as washers behind metallic cavity fixings used to support the appliance. The washers spread the load exerted by the legs of the cavity fixings and increase the pull-out resistance. Access can only be gained to those fixings near to the chimney system opening in the wall.

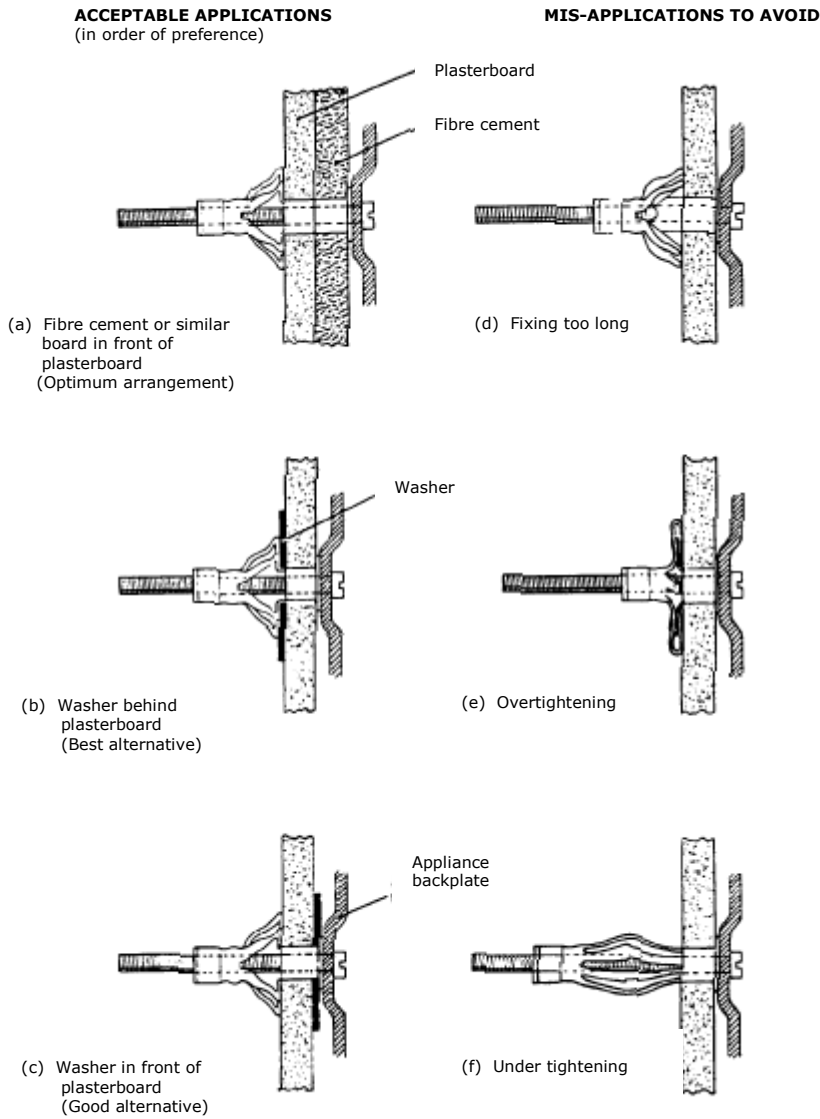
Where access cannot be gained behind the plasterboard, i.e. those fixing points remote from the flue opening, then washers placed on the front surface of the plasterboard serve a similar, though somewhat less effective, purpose. Thus, for an appliance with four fixings, the two closest to the flue opening need to have washers behind the plasterboard and the two furthest from the flue opening to have washers in front of the plasterboard.

These washers can be made of 16 swg galvanised steel or similar material with no sharp burrs which could dig into the plasterboard. They need an outside diameter of at least 50 mm or have an equivalent area if they are not circular. The hole needs to be sized to accommodate the shank of the fixings to be used.

Because of the number and type of fixings available it is not possible to be specific on fixings for a given weight of appliance. The appliance manufacturer should be able to advise on the weight of the appliance in service and the board manufacturer the most suitable fixings.

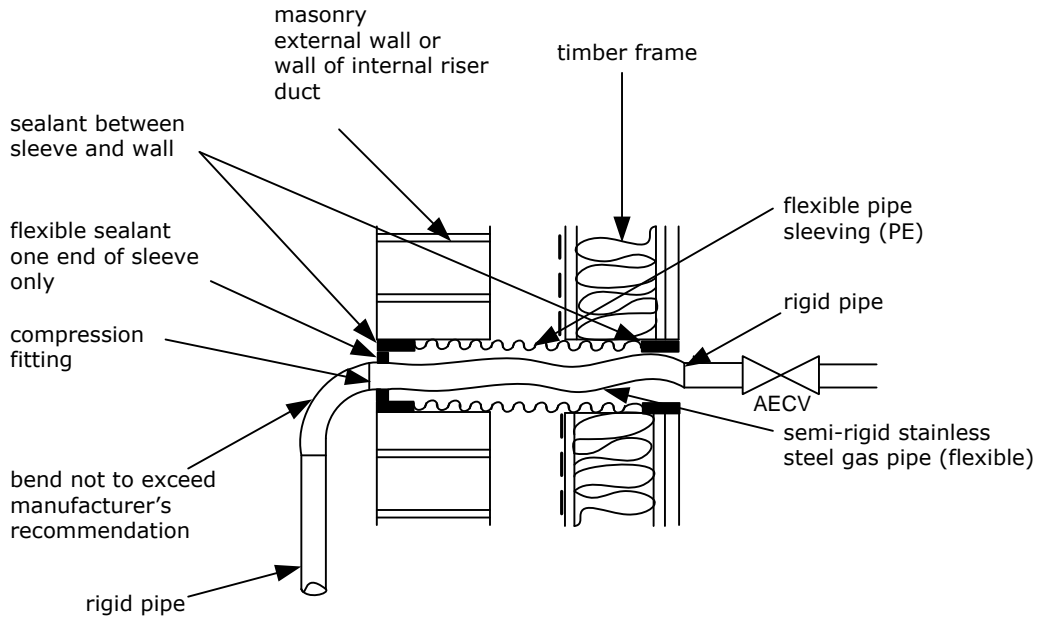
*Note: Cavity fixings require care when fitting. For some fixings, an appropriate setting tool is recommended since it not only increases the speed of fixing but controls the consistency of the correct deformation of the legs of the fixing. The fixing manufacturer's instructions apply with particular care being taken to:*

- (i) *select the fixing to suit the thickness of the plasterboard (typically 12.5 mm on external walls and 32 mm on separating walls);*
- (ii) *use a drill of the recommended size;*
- (iii) *avoid deforming the legs of the fixing before installation;*
- (iv) *avoid over-tightening; and*
- (v) *check the deformation of the legs behind the plasterboard via the room sealed chimney system.*

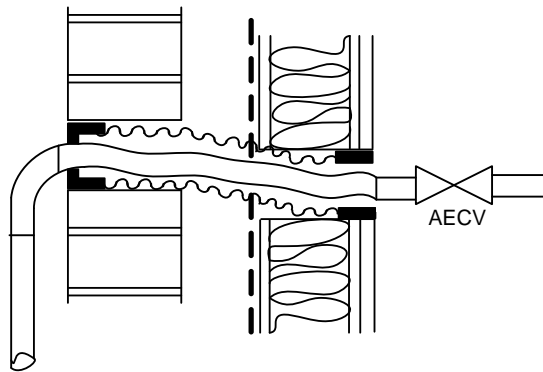


**FIGURE 26 – ACCEPTABLE AND NOT ACCEPTABLE APPLICATIONS OF TYPICAL METALLIC CAVITY FIXINGS**

## APPENDIX 6 : A TYPICAL METHOD OF ACCOMMODATING MOVEMENT FOR PIPEWORK PASSING THROUGH A TIMBER FRAME/MASONRY WALL



**(a) As installed – before movement of timber**



**(b) After relative movement of timber**

*Note 1: This method is not acceptable for Network pipelines or service pipework for which the use of the semi-rigid stainless steel gas pipe is not permitted. The method can only be adopted for installation pipework.*

*Note 2: Specific pipe and sleeve arrangements are a matter of normal detailed design considerations. Appendix 3 provides information on allowances for differential movement of timber frame and masonry structures.*

*Note 3: The diagrams are intended to demonstrate the principles only. The manufacturer's recommendations with respect to the capabilities of the flexible pipe and sleeve have to be followed.*

**FIGURE 27 - A SCHEMATIC ARRANGEMENT FOR ACCOMMODATING MOVEMENT FOR PIPEWORK PASSING THROUGH A TIMBER FRAME/MASONRY WALL**

# Communication 1722

## Price Code: T5

ISBN 0-7177-0097-6

ISSN 0367-7850

This copyright publication forms part of a series of Procedures published by the Institution of Gas Engineers and Managers, Charnwood Wing, Holywell Park, Ashby Road, Loughborough, Leicestershire, LE11 3GH.

The latest titles that are currently available in this series are the following:

<i>Item No.</i>	<i>Title</i>	<i>Date of Current Edition</i>	<i>Comm No</i>
IGE/UP/1 Edition 2 Reprint with Amendments	Strength testing, tightness testing and direct purging of industrial and commercial gas installations	2005	1716
IGE/UP/1A Edition 2 Reprint with Amendments	Strength testing, tightness testing and direct purging of small low pressure industrial and commercial Natural Gas installations	2005	1717
IGE/UP/1B Edition 2	Tightness testing and direct purging of small Natural Gas installations	2006	1714
►IGEM/UP/2 Edition 2	Gas installation pipework on industrial and commercial premises◀	2008	1729
IGE/UP/3 Edition 2	Gas fuelled spark ignition and dual fuel engines	2006	1720
IGE/UP/4 Edition 2	Commissioning of gas fired plant on industrial and commercial premises	1998	1653
IGE/UP/6	Application of positive displacement compressors to Natural Gas fuel systems	1998	1646
IGE/UP/7 Edition 2	Gas installations in timber framed and light steel framed buildings	2006	1722
IGE/UP/8	Gas installations for caravan holiday homes, residential park homes and permanently moored boats	2001	1647
IGE/UP/9 Edition 2	Application of Natural Gas fuel oil systems to gas turbines and supplementary and auxiliary fired burners	2004	1705
IGE/UP/10 Edition 2	Installation of gas appliances in industrial and commercial premises Part 1 : Flued appliances	2002	1676
IGE/UP/11	Gas installations for educational establishments	2004	1704
IGE/UP/12	Application of burners and controls to gas fired process plant	2006	1713