

Meter installations of flow exceeding 6 m³ per hour

Part 2 Location, housings and compounds

DRAFT FOR COMMENT

- 1 This draft Standard IGEM/GM/8 Part 2 Edition 3 has been prepared by a Panel under the chairmanship of David Harper.
- 2 This Draft for comment is presented to Industry for comments which are required by 29th November 2024, and in accordance with the attached Reply Form.
- 3 This is a draft document and should not be regarded or used as a fully approved and published Standard. It is anticipated that amendments will be made prior to publication.
It should be noted that this draft Standard contains intellectual property belonging to IGEM. Unauthorised copying or use by any unauthorised person or party is not permitted.
- 4 This is a copyright document of the Institution of Gas Engineers and Managers. Enquiries should be addressed in the first instance to:

*Peter Hurst
IGEM
IGEM House
26-28 High Street
Kegworth
Derbyshire, DE74 2DA
Tel: 01509 678150
Email: peter@igem.org.uk*



Founded 1863
Royal Charter 1929
Patron: His Majesty the King





Attached is the Draft for Comment of IGEM/GM/8 Edition 3 – “Meter installations of flow exceeding 6 m³ per hour” and the associated comment form.

We wish to make it as easy as possible for those of you representing industry bodies to issue the draft to your Members. You can either forward this email with attachment complete or forward it without the attachment and invite them to visit our website via <https://www.igem.org.uk/technical/technical-services/comment-on-draft-standards.html> where the Draft and Comment Form is posted.

Organisations to which this Draft has been circulated:

Organisation	Representative
AMO	ERIC FOWLER
BPEC	MALLY BUTTERS
BRITISH GAS	BRETT JOHNSON
CADENT	HILARY BUXTON
CMAP	JOHN HEYBURN
DNO COLLAB FORUM	HILARY BUXTON
EI	MARK SCANLON
ENA	JAMES EARL
EUA	STEVE SUTTON
EUSKILLS	RICHARD HARPER
GSR	JONATHAN PALMER
GISG	BOB MURRY
HHIC	STEVEN SUTTON
HSENI	SEAN KEOGH
*Large Business Forum	TREVOR SMALLPEICE
LLOYDS REGISTER	LES THOMAS
RETAIL ENERGY CODE (REC)	ERIC FOWLER
NGN	IAIN FOSTER
OFGEM	VIC TUFFEN
SGN	DOMINIC CUMMINGS
WALES & WEST	GRANT ROGERS
YPN	HARRIET GUIRY.

IGEM/GM/8 Part 2 Edition 3
Communication **XXXX**

***Meter installations of flow exceeding
6 m³ per hour***

Part 2 : Location, housings and compounds

DRAFT FOR COMMENT



*Founded 1863
Royal Charter 1929
Patron: His Majesty the King*



IGEM/GM/8 Part 2 Edition 3
Communication **XXXX**

Meter installations of flow exceeding 6 m³ per hour

Part 2 : Location, housings and compounds

DRAFT FOR COMMENT



Price Code: C3S
© The Institution of Gas Engineers and Managers
IGEM House
26-28 High Street
Kegworth
Derbyshire, DE74 2DA
Tel: 0844 375 4436
Fax: 01509 678198
Email: general@igem.org.uk

Copyright © 2024, IGEM. All rights reserved
Registered charity number 214011

All content in this publication is, unless stated otherwise, the property of IGEM. Copyright laws protect this publication. Reproduction or retransmission in whole or in part, in any manner, without the prior written consent of the copyright holder, is a violation of copyright law.

ISBN 978 1 xxxxxx-xx-x

Published by the Institution of Gas Engineers and Managers

Previous Publications:

Communication 1707 (2005) – 1st Edition

Communication 1796 (2016) – 2nd Edition

For information on other IGEM Standards please visit our website, www.igem.org.uk

CONTENTS

SECTION	PAGE	
1	Introduction	1
2	Scope	4
3	Legal and allied considerations	5
	● 3.1 General	5
	● 3.2 Building Regulations	5
	● 3.3 Confined Spaces Regulations	6
	● 3.4 Construction (Design and Management) Regulations (CDM)	6
	● 3.5 Control of Asbestos Regulations	6
	● 3.6 Control of Substances Hazardous to Health Regulations (COSHH)	7
	● 3.7 Dangerous Substances and Explosive Atmospheres Regulations (DSEAR)	7
	● 3.8 Electricity at Work Regulations	7
	● 3.9 Gas Act	8
	● 3.10 Gas Safety (Installation and Use) Regulations (GS(I&U)R)	8
	● 3.11 Health and Safety at Work etc. Act (HSWA)	8
	● 3.12 Lifting Operations and Lifting Equipment Regulations	8
	● 3.13 Management of Health and Safety at Work Regulations (MHSWR)	8
	● 3.14 Manual Handling Operations Regulations	8
	● 3.15 Provision and Use of Work Equipment Regulations (PUWER)	9
	● 3.16 Reporting of Injuries, Diseases and Dangerous Occurrences Regulations (RIDDOR)	9
4	Objectives and principles	11
	● 4.1 Objectives	11
	● 4.2 Principles	11
5	Exchange of information	12
	● 5.1 General	12
	● 5.2 Materials and construction	12
	● 5.3 Formal documentation	12
6	GT authorisations	14
7	General considerations	16
	● 7.1 General	16
	● 7.2 Safety and safe working access	16
	● 7.3 Space heating	18
	● 7.4 Labelling	18
	● 7.5 Durability	18
	● 7.6 Statutory Regulations	18
8	Location	19
9	Ventilation of housings	21

10	Thermal and acoustic insulation	23
11	Construction and materials for housings	24
	• 11.1 Design	24
	• 11.1.1 All housings	24
	• 11.1.2 Glass reinforced plastic (GRP) housings	25
	• 11.2 Foundations, bases and floor mounting	26
	• 11.2.1 All housings/compounds	26
	• 11.2.2 Prefabricated housings (including GRP)	27
	• 11.2.3 GRP housings	27
	• 11.3 Doors	27
	• 11.4 Walls	29
	• 11.4.1 All housings	29
	• 11.4.2 Prefabricated housings (including GRP)	30
	• 11.5 Roofs and lift off Panels	30
	• 11.6 Finish	30
	• 11.7 Performance	31
	• 11.7.1 All housings	31
	• 11.7.2 GRP housings	31
	• 11.8 Fire Resistance	31
12	Outdoor compounds	32
13	Pits	33
	• 13.1 General	33
	• 13.2 Ventilation	33
	• 13.2.1 Internal volume $\leq 0.5 \text{ m}^3$	33
	• 13.2.2 Internal volume $> 0.5 \text{ m}^3$	33
	• 13.3 Pit covers	35
14	Explosion reliefs	36
15	Lightning conductors	37
APPENDIX		
1	Glossary, acronyms, abbreviations, units and symbols	38
2	References	40
3	Design of explosion reliefs	44
4	Performance tests for GRP housings	46
FIGURE		
1	Lift off housings/covers. Ease of handling	17
2	Access classification	25
3	Provision of exits in long "walk-in" housings	28
4	Termination of ventilation ducts from a pit	34
5	Explosion relief roof design	45
6	Impact tool	47

SECTION 1 : INTRODUCTION

- 1.1 This Standard supersedes IGEM/GM/8 Part 2, Communication 1796, which is obsolete.
- 1.2 This Standard has been drafted by an Institution of Gas Engineers and Managers (IGEM) Panel, appointed by IGEM's Gas Measurement Committee and subsequently approved by that Committee, and has been approved by IGEM's Technical Co-ordinating Committee on behalf of the Council of IGEM.
- 1.3 IGEM/GM/8 is published in 5 parts:
- Part 1 covering design
 - Part 2 covering locations, housings and compounds
 - Part 3 covering installation and commissioning
 - Part 4 covering operation and maintenance
 - Part 5 covering notices and labels.
- 1.4 This Standard covers the design of gas supply meter installations (see Sub-Section 2.1) of capacity exceeding $6 \text{ m}^3 \text{ h}^{-1}$ and maximum operating pressure (upstream) (MOP_u) not exceeding 38 bar.

With the exception of the few installations of MOP_u exceeding 38 bar, the majority of industrial and commercial meter installations can be designed by following IGEM/GM/6 (for MOP_u not exceeding 100 mbar only) and/or IGEM/GM/8.

Note: IGEM Standards use pressure breaks as adopted in European standards. However, in the UK, the actual limit of pressure for IGEM/GM/6 designs is 75 mbar. In practice, it is rare for a meter installation to have MOP_u lying between 75 mbar and 100 mbar, in the UK.

It is the intention that IGEM/GM/6 be used for the largest proportion of installations that can be covered by "standard designs" for MOP_u not exceeding 100 mbar.

For $100 \text{ mbar} < \text{MOP}_u \leq 38 \text{ bar}$ or where an installation is not a "standard design" as specified in IGEM/GM/6, IGEM/GM/8 applies (see also Note 4 to Sub-Section 2.1).

For a turbine meter installation of MOP_u not exceeding 100 mbar, there are no recognised standard designs i.e. IGEM/GM/6 does not apply. It is recommended that IGEM/GM/8 be used for all such installations.

For any meter installation of MOP_u exceeding 38 bar, IGEM/GM/4 applies.

- 1.5 This Standard applies to new, onshore, gas supply installations only. It is not retrospective. However, where work needs to be undertaken on a meter installation, it is recommended that such an installation be brought into line with this Standard. In particular, any unregulated by-pass needs to be removed or a regulator installed in the by-pass.

When re-engineering or replacing legacy meter installations, consideration is to be given to bringing them in line with the standard arrangements within IGEM/G/1. Unless all involved parties are in agreement to continue the legacy arrangement, it is expected that if reasonably practicable such existing systems will be modified to meet the recommended approach.

Irrespective of whether an emergency control valve (ECV) is fitted to the inlet of the meter installation, it is recommended that modification work be undertaken in line with this Standard.

Ownership and responsibility for new installations covered by this Standard has been liberalised from gas transporters (GTs) to Meter Asset Providers (MAPs) who are the title owner of the assets, and Meter Asset Managers (MAMs) responsible for management. The regulation authority, the Office of Gas and Electricity Markets (Ofgem) require that asset managers and installers are separately accredited for the work they carry out. Approved MAMs have operational and management responsibility while Accredited Meter Installers (AMIs) carry out meter work, installation, modification, repair, maintenance and removal activities, both work to the Retail Energy Code Consolidated Metering Code of Practice (CoMCoP).

Licence conditions make gas suppliers responsible for coordinating the provision of metering services and have placed responsibilities on GTs to underpin the overall safety of the gas supply system from the distribution main to the inlet to the consumer's appliances.

Note: Under these arrangements, a REC MAM does not have to be an AMI, but has an obligation to use an AMI to carry out work on a meter installation or have the work inspected by an AMI within 20 days of the work.

Notwithstanding Sub-Section 1.11, total compliance with IGEM/GM/8 is necessary for installations and modules where the meter installation has to comply with ComCoP.

- 1.6 Where applicable, the requirements of IGEM/GL/5 are to be considered.
- 1.7 Terms such as "maximum operating pressure" (MOP), "maximum incidental pressure" (MIP) and "operating pressure" (OP) are used to reflect gas pressure terminology used in European standards. These terms are used in all relevant IGEM standards and, possibly, in other standards. Other terms have been introduced to assist in recognition of design information to be transferred between interested parties.
- 1.8 This Standard makes use of the terms "must", "shall" and "should" when prescribing particular procedures. Notwithstanding Sub-Section 1.11:
- the term "must" identifies a requirement by law in Great Britain (GB) at the time of publication
 - the term "shall" prescribes a procedure which, it is intended, will be complied with in full and without deviation
 - the term "should" prescribes a procedure which, it is intended, will be complied with unless, after prior consideration, deviation is considered to be acceptable.
- Such terms may have different meanings when used in Legislation, or Health and Safety Executive (HSE) Approved Code of Practice (ACoPs) or guidance, and reference needs to be made to such statutory legislation or official guidance for information on legal obligations.
- 1.9 The primary responsibility for compliance with legal duties rests with the employer. The fact that certain employees, for example "responsible engineers", are allowed to exercise their professional judgement does not allow employers to abrogate their primary responsibilities. Employers are required to:
- have done everything to ensure, so far as it is reasonably practicable, that "responsible engineers" have the skills, training, experience and personal qualities necessary for the proper exercise of professional judgement
 - have systems and procedures in place to ensure that the exercise of professional judgement by "responsible engineers" is subject to appropriate monitoring and review

- not require “responsible engineers” to undertake tasks which would necessitate the exercise of professional judgement that is not within their competence. There are written procedures defining the extent to which “responsible engineers” can exercise their professional judgement. When “responsible engineers” are asked to undertake tasks which deviate from this, they are to refer the matter for higher review.

1.10 It is now widely accepted that the majority of accidents in industry generally are in some measure attributable to human as well as technical factors in the sense that actions by people initiated or contributed to the accidents, or people might have acted in a more appropriate manner to avert them.

It is therefore necessary to give proper consideration to the management of these human factors and the control of risk. To assist in this, it is recommended that due regard be paid to HSG48.

1.11 Notwithstanding Sub-Section 1.8, this Standard does not attempt to make the use of any method or specification obligatory against the judgement of the responsible engineer. Where new and better techniques are developed and proved, they are to be adopted without waiting for modification to this Standard. Amendments to this Standard will be issued when necessary, and their publication will be announced in the Journal of the Institution and elsewhere as appropriate.

1.12 Requests for interpretation of this Standard in relation to matters within their scope, but not precisely covered by the current text, should be addressed in writing to:

- Technical Services, The Institution of Gas Engineers and Managers, IGEM House, 26 & 28 High Street, Kegworth, Derbyshire DE74 2DA, or
- emailed to technical@igem.org.uk,
and will be submitted to the relevant Committee for consideration and advice, but in the context that the final responsibility is that of the engineer concerned. If any advice is given by or on behalf of IGEM, this does not relieve the responsible engineer of any of their obligations.

1.13 This Standard was published in xxxxxxxx 2024.

SECTION 2 : SCOPE

2.1 This Standard applies to new locations, housings and compounds for gas supply meter installations (hereafter referred to as "installations" (and defined in IGEM/G/1)) of flow rate (capacity) exceeding $6 \text{ m}^3 \text{ h}^{-1}$ and MOP upstream (MOP_u) not exceeding 38 bar.

Installations with the following types of meter are covered:

- diaphragm
- rotary displacement (RD)
- turbine
- ultrasonic (USM)
- thermal mass.

Note 1: For installations of capacity not exceeding $6 \text{ m}^3 \text{ h}^{-1}$, intended to carry Natural Gas (NG), BS 6400-1 or BS 6400-2 apply, as appropriate for MOP_u . For non-domestic premises there are additional legal requirements that may have to be met, e.g. DSEAR.

The requirements of this document may be applied to installations of capacity not exceeding $6 \text{ m}^3 \text{ h}^{-1}$ and MOP_u exceeding 2 bar.

Note 2: For installations of MOP_u exceeding 38 bar, IGEM/GM/4 applies and IGEM/GM/8 Part 2 may be additionally applied.

Note 3: Principally IGEM/GM/8 has been produced for primary meters and other meters used for billing purposes. However, its principles may be applied for other meters, for example, appliance check meters or departmental charging meters, when certain requirements may not apply.

Note 4: IGEM/GM/6 provides procedures of meter "standard" designs of MOP_u not exceeding 75 mbar. For other, "non-standard" installations of MOP_u not exceeding 100 mbar, IGEM/GM/8 applies. See also the note within Sub-Section 1.4.

2.2 This Standard applies to locations, housings and compounds for installations intended to carry NG (a 2nd family gas as defined by BS EN 437).

Note: The Gas Safety (Installation and Use) Regulations (GS(I&U)R) define "gas" to include 1st, 2nd and 3rd family gases as well as other gases. The principles of IGEM/GM/8 may be used for gases other than NG but suitable adjustments to parameters and requirements will need to be considered by a competent person.

2.3 This Part 2 of IGEM/GM/8 deals with the selection of location and the design of bases, housings and compounds for relevant installations.

2.4 All pressures are gauge pressures unless otherwise stated.

2.5 Italicised text is informative and does not represent formal requirements.

2.6 Appendices are informative and do not represent formal requirements unless specifically referenced in the main sections via the prescriptive terms "must", "shall" or "should".

SECTION 3 : LEGAL AND ALLIED CONSIDERATIONS

3.1 GENERAL

3.1.1 This Standard is set out against a background of Legislation in force in GB at the time of publication. The devolution of power to the Scottish, Welsh and Northern Ireland Assemblies means that there may be variations to the Legislation described below for each of them and consideration of their particular requirements must be made. Similar considerations are likely to apply in other countries where reference to appropriate national legislation is necessary.

All relevant legislation must be applied and relevant ACoPs, official Guidance Notes and referenced codes, standards, etc. shall be taken into account.

Note: Appendix 2 is relevant in this respect.

Where British Standards, etc. are quoted, equivalent national or international standards, etc. equally may be appropriate.

3.1.2 Persons who design meter installations must have a knowledge and understanding of the standards and regulations that apply to ensure that the completed plans will produce a safe and satisfactory installation.

Persons who install or maintain meter installations must be competent to do so and compliance with GS(I&U)R must be achieved where those Regulations apply.

At the time of publication, the body with HSE approval to operate and maintain a register of businesses who are "members of a class of persons" is Gas Safe Register. Therefore, all businesses or self-employed gas fitters working on meter installations must be registered with Gas Safe Register where GS(I&U)R apply.

Persons deemed competent to carry out gas work are those who hold a current certificate of competence in the type of activity to be conducted, issued by a certification body accredited by the United Kingdom Accreditation Service (UKAS). UKAS issue certificates of competence under the National Accredited Scheme for Individual Gas Fitting Operatives (ACS).

Compliance shall be achieved with the Retail Energy Code Consolidated Metering Code of Practice (CoMCoP).

3.2 BUILDING REGULATIONS

3.2.1 England and Wales (as Amended)

Building Regulations are Statutory Instruments that are to be followed when engaged in any building work. They are written in a format of broad Regulations, setting out simple requirements in a separate Schedule. Suggested ways of complying with these Regulations are contained in Approved Documents.

The Approved Documents that apply to gas work with respect to this Standard are:

- A (Structure)
- B (Safety in Fire)
- F (Ventilation).

3.2.2 **Building Standards (Scotland) Regulations and Amendments**

The Building Standards (Scotland) are written directly as Regulations within the Statutory Instrument. The Regulations can be satisfied by:

- compliance with Technical Standards published by the Scottish Government
- conforming with the provisions of "deemed to satisfy" documents, for example British Standards
- other equivalent means.

3.3 **CONFINED SPACES REGULATIONS**

These Regulations apply to a whole range of confined spaces. The supplier or designer of an enclosure and equipment within it is required to perform a risk assessment of the enclosure with respect to safe access and egress and to give clear instructions to operators on access/egress as well as to what actions to take in the event of a gas alarm occurring. Employers and the self-employed are required to prevent entry into confined spaces unless avoidance is not reasonably practicable and unless there is a system of work which renders the work safe. They are also required to have specific emergency arrangements in place.

3.4 **CONSTRUCTION (DESIGN AND MANAGEMENT) REGULATIONS (CDM)**

3.4.1 These Regulations impose duties on designers, clients (and their agents), developers, principal designer and principal contractors.

Further information is given in L153, which sets out the principles duty holders are required to use in their approach to identifying the measures they need to take to control the risks to health and safety in a particular project.

The general principles of prevention are to:

- avoid risks where possible
- evaluate those risks that cannot be avoided, and
- put in place proportionate measures that control them at source.

Construction includes the alterations, repair, re-decoration, maintenance, de-commissioning or demolition of a structure. It also covers installation, commissioning, maintenance or removal of gas services.

3.5 **CONTROL OF ASBESTOS REGULATIONS**

3.5.1 These Regulations set out standards for the identification, monitoring and assessment of work that may expose workers to asbestos and the measures needed to control the risk.

3.5.2 Employers are required not to carry out any work that exposes, or is likely to expose, employees to asbestos unless an assessment of that exposure has been made. Employers have to set out steps to be taken to prevent, or reduce to the lowest level reasonably practicable, that exposure. Employers have to carry out medical surveillance of employees if they work over a certain time limit.

3.5.3 The Regulations impose a duty on those with responsibilities for the repair and maintenance of non-domestic premises to find out if there are, or may be, asbestos containing materials within them; to record the location and condition of such materials and assess and manage any risk from them, including passing of any information about their location and condition to anyone likely to disturb them.

3.5.4 Further information is available in HSG227. Other AcoPs associated with these Regulations are L143 and INDG223.

3.6 **CONTROL OF SUBSTANCES HAZARDOUS TO HEALTH REGULATIONS (COSHH)**

3.6.1 These Regulations, which reinforce existing statutory obligations under HSWA, impose a duty on employers to protect employees against risks to health, whether immediate or delayed, arising from exposure to substances hazardous to health, either used or encountered, as a result of a work activity. They also impose certain duties on employees.

3.6.2 Under COSHH, work is not to be carried out which is liable to expose employees to hazardous substances unless the employer has made a suitable and sufficient assessment of the risk created by the work and the steps that need to be taken to comply with the Regulations. After assessing the risk, it is necessary to inform employees of the risks and to carry out the appropriate training and instruction to ensure the risks are minimised. In certain cases, control measures such as ventilation or personal protective equipment may be necessary and, where provided, they are required to be used.

3.7 **DANGEROUS SUBSTANCES AND EXPLOSIVE ATMOSPHERES REGULATIONS (DSEAR)**

These Regulations are concerned with protection against risks from fire, explosion and similar events arising from dangerous substances used or present in the workplace. The Regulations require that risks from dangerous substances are assessed, eliminated or reduced. They contain specific requirements to be applied where an explosive atmosphere may be present and require the provision of arrangements to deal with accidents, emergencies etc. and provision of information, training and use of dangerous substances. The Regulations also require the identification of pipelines and containers containing hazardous substances.

The following publications contain details of the Regulations and their application:

- L138
- INDG 370.

3.8 **ELECTRICITY AT WORK REGULATIONS**

These Regulations apply to a wide range of electrical work, from overhead power lines to the use of office computers and batteries and include work on gas equipment using electrical energy.

They are concerned with the prevention of danger from electric shock, electric burn, electrical explosion or arcing, or from fire or explosion initiated by electrical energy.

They impose duties on every employer, employee and self-employed person and require that persons engaged in electrical work be competent or be supervised by competent persons.

Note: A "Memorandum of Guidance on the Electricity at Work Regulations, 1989" is available from HSE and gives useful information on the Regulations. Further advice is contained in HSR25.

3.9 **GAS ACT**

This Act defines the circumstances under which the location, housing and design are subject to GT authorisation.

3.10 **GAS SAFETY (INSTALLATION AND USE) REGULATIONS (GS(I&U)R)**

3.10.1 GS(I&U)R are relevant statutory provisions of HSWA setting out general and detailed requirements dealing with the safe installation, maintenance and use of gas systems, including gas fittings, appliances and flues.

3.10.2 GS(I&U)R define the gas supplier for NG and L56 provides guidance on those definitions.

3.10.3 GS(I&U)R define the type of work that requires persons carrying out such work, or their employers, to be an "approved class of person", for example to be on the Gas Safe Register.

3.10.4 The installer is required to check the safety of any meter installation they install or work on and take appropriate action where they find faults. Where the premises are let or hired out, the landlord or hirer has special responsibilities to ensure that any installer they use for the gas fitting, service or maintenance is a member of an approved class of persons (see clause 3.10 3) and is competent to carry out such work. If any serious fault is found, the installer is required to inform both the landlord/hirer, as well as the user, so that such faults can be rectified before further use. Information covering such incidents is to be found in the Gas Industry Unsafe situations procedure IGEM/G/11.

3.11 **HEALTH AND SAFETY AT WORK ETC. ACT (HSWA)**

HSWA applies to all persons involved with work activities, including employers, the self-employed, employees, designers, manufacturers, suppliers etc. as well as the owners of premises. It places general duties on such people to ensure, so far as is reasonably practicable, the health, safety and welfare of employees and the health and safety of other persons such as members of the public who may be affected by the work activity.

3.12 **LIFTING OPERATIONS AND LIFTING EQUIPMENT REGULATIONS (LOLER)**

These Regulations build on Provision and Use of Work Equipment Regulations (PUWER) (see Sub-Section 3.15).

Practical guidance on these Regulations is given in L113.

3.13 **MANAGEMENT OF HEALTH AND SAFETY AT WORK REGULATIONS (MHSWR)**

In addition to specific duties under GS(I&U)R (see Sub-Section 3.4) MHSWR impose a duty on employers and the self-employed to make assessments of risks to the health and safety of employees, and non-employees affected by their work. They also require effective planning and review of protective measures.

3.14 **MANUAL HANDLING OPERATIONS REGULATIONS**

These Regulations seek to reduce the very large incidence of injury and ill-health arising from the manual handling of loads at work. More than 1 in 4 of all reportable injuries are caused by manual handling. These accidents do not

include cumulative injuries, particularly to the back which can lead to physical impediment or even permanent disablement.

These Regulations place duties upon employers in respect of their own employees. Identical duties are placed on the self-employed in respect of their own safety.

3.15 **PROVISION AND USE OF WORK EQUIPMENT REGULATIONS (PUWER)**

3.15.1 Work equipment has a wide meaning and includes tools such as hammers, laboratory apparatus, for example Bunsen burners, ladders, photocopiers, lifting equipment and machinery for use at work.

3.15.2 These Regulations place duties on employers in relation to selection, suitability, maintenance, inspection, installation, instruction and training, prevention of danger and control of equipment.

3.15.3 More information on these Regulations can be found in L22 and free leaflets include INDG 291 and INDG 229.

3.16 **REPORTING OF INJURIES, DISEASES AND DANGEROUS OCCURRENCES REGULATIONS (RIDDOR)**

3.16.1 RIDDOR require employers, self-employed people or those in control of work premises to report certain work related accidents, diseases and dangerous occurrences.

3.16.2 Other people have duties to report certain gas incidents which may not appear to be work related:

- death, major injury, lost consciousness, or being taken to hospital for treatment to an injury arising out of the distribution, filling, import or supply of NG are to be reported by the conveyor
- dangerous gas fittings (as defined in RIDDOR) is required to be reported by a "member of a class of persons".

3.16.3 Major injuries, death and dangerous occurrences are required to be notified immediately, for example by telephone, to the enforcing authority by the "responsible person" as defined by RIDDOR. Reports can be made to the Incident Contact Centre:

- For fatal and major injuries only, telephone on 0845 300 9923 (opening hours Monday to Friday 8.30 am to 5 pm) and complete appropriate online form
- all other reports at HSE website www.hse.gov.uk.

Complete the appropriate online report form listed below:

- report an injury
- report of a dangerous occurrence
- report of an injury offshore
- report of a dangerous occurrence offshore
- report of a case of disease
- report of a flammable gas incident
- report of a dangerous gas fitting.

The form will then be submitted directly to the RIDDOR database and a copy issued to the person making the report.

Online written reports are to be submitted within the required timescale (10 days, or 14 days for dangerous gas fittings). Other reports need to be made as soon as practicable and within 10 days of the incident.

- 3.16.4 INDG 453 contains detailed guidance on RIDDOR, including a full list of injuries etc. that need reporting.
- 3.16.5 IGEN/GL/8 provides guidance on the reporting and investigation of gas-related incidents.

SECTION 4 : OBJECTIVES AND PRINCIPLES

4.1 OBJECTIVES

The primary objectives when designing any housing or compound shall be to ensure, as far as possible:

- safety of persons and plant
- the optimisation of the asset life of the installation
- reliability of operation, including the required level of security of the gas supply
- security and protection against vandalism and mechanical damage
- sufficient space for general access and adequate provision for safe maintenance
- due allowance for the accommodation of equipment that may be installed in addition to the meter installation, for example a volume converter, other instrumentation, etc.
- a suitable location for the GT's ECV.

4.2 PRINCIPLES

4.2.1 The selection of the location and the design of the housing/compound depend upon individual circumstances of the site and the equipment used. They shall take into account such factors as security, adequate access for maintenance and meter reading, weather protection, noise, other local conditions and constraints imposed by the consumer, e.g. any hazardous area identified by the consumer that may affect the location of the installation.

Note: The installation may be:

- *in a main building*
- *in a prefabricated housing delivered to, and installed on site*
- *in a purpose-designed and built housing, on site*
- *in a suitably converted existing building*
- *if suitable, outdoors and protected by a perimeter fence.*

4.2.2 The design of any housing shall take into account the need for handling of the housing, or part of the housing, during installation/construction and maintenance of the meter installation.

Note: Such handling may be either by mechanical or manual means, as appropriate to the size of the housing.

4.2.3 Due account shall be taken of any local Planning Department's requirements and restrictions.

4.2.4 Approval shall be obtained from the GT for the design of meter housing/accommodation in accordance with GDN/PM/GT2.

SECTION 5 : EXCHANGE OF INFORMATION

5.1 GENERAL

- 5.1.1 The location of the installation shall be agreed between the consumer, supplier, GT and installer.
- 5.1.2 Any constraints, imposed by the consumer, which may affect safety, shall be determined, for example any hazardous area which may affect the location of the installation.
- 5.1.3 In consultation with the consumer, it shall be determined which party will provide the housing, and what type of housing is to be used.
- 5.1.4 Where the consumer will provide the housing:
- the MAM should advise the consumer of their requirements for a satisfactory housing and location, and
 - the consumer shall be advised that GT authorisation will be necessary (see Section 6).
- 5.1.5 Ownership and responsibility for ongoing maintenance of the housing and compound should be established and documented.

5.2 MATERIALS AND CONSTRUCTION

Where housing construction (other than for a prefabricated glass reinforced plastic (GRP) housing) is contracted to a builder, the builder shall provide, to the project management company (which may be the MEM, consumer, etc.) details of all materials to be used. This should include details of the roof construction, including the fixing method. Such details shall be submitted on a suitable specification form.

Details of any specific requirements for bricks, tiles etc. shall be included on the specification form, by the project manager.

Note: This applies, for example, where a specific colour, type and manufacture of brick is required.

5.3 FORMAL DOCUMENTATION

- 5.3.1 The following documents shall be produced, as appropriate:
- planning application, including drawings
 - site layout drawing
 - general arrangement drawing
 - detailed fabrication and construction drawings and specifications
 - as-built drawings
 - design calculations.
- 5.3.2 Planning application drawings, whether for a “full planning permission” or approval of a “permitted development” application, are required to show the proposal and should contain sufficient information to demonstrate the general appearance of the housing/compound upon completion. The drawing should contain a location plan, site plan and at least two elevations.
- 5.3.3 Site layout drawings may also be required for site construction works. These should show sufficient detail to identify the site location, orientation and boundaries, as well as the exact position of any housing/compound to be located on the site.

- 5.3.4 General arrangement drawings should provide at least the following information:
- setting out of the housing/compound in plan position
 - plans, sections and elevations, as appropriate, showing layout, dimensions and levels of all aspects of the structure
 - location of all access doors, holes, chases, pockets, ventilation, fixings and other items
 - details of materials to be used, for example brick type, colour and supplier
 - details of surface finishes, both internally and externally, including colour
 - all other information necessary to permit construction in accordance with design requirements, for example type and location of holding down fixings.
- 5.3.5 Detailed fabrication and construction drawings should indicate any specific manufacturing or construction detail that is not indicated on the general arrangement drawing. Copies of these drawings shall be submitted for acceptance by the project manager prior to commencement of any fabrication or construction work.
- 5.3.6 As-built drawings should indicate the details of the completed construction and should also identify all changes from the construction issue drawings. Copies of the drawings should be provided by the contractor, or supplier, to the project manager on completion of site works.
- 5.3.7 Calculations for all structural elements and their fixings shall be checked and approved.

SECTION 6 : GT AUTHORISATIONS

- 6.1 The location of a meter installation influences the location of the associated ECV. The responsible person shall agree the location of the ECV with the GT or Utility Infrastructure Provider (UIP).

Note: The majority of GTs operate a site works process that includes the agreement of the location of the ECV.

The responsible person shall submit a request for housing/compound approval and obtain authorisation from the GT.

Note: It may be possible to obtain a generic approval from the GT for housings complying with approved specifications.

- 6.2 For GT authorisation the location and design procedure should take into consideration:

- installation as close as practicable to the Network pipeline (see Section 8)
- adequate ventilation levels (see Section 9)
- an explosion relief, if required
- the design of relief vent stacks
- adequate access for both the consumer and the gas emergency service provider (ESP) to operate the ECV
- the avoidance of an unsafe environment created by the gas supply, for example by the position of vent stacks
- the nature of the existing area, for example Zone 1, 2, and non-hazardous area, etc.
- the proximity of any ignition sources
- compliance with relevant legislation
- requirement of the GT to undertake its obligations under GS(I&U)R and the Gas Safety (Management) Regulations (GS(M)R)
- adequate protection against vandalism and unauthorised access
- the GT will need to be informed of any special precautions to be taken before entering the housing/compound
- the need to be able to read the meter
- the need to be able to undertake scheduled safety inspections.

Note: A GT may make available an information service on approval requirements from its customer service desk.

- 6.3 The following information should be provided to the GT as part of the approval procedure, see GDN/PM/GT2:

- registration details, including name, address, telephone number and any other registration body details that demonstrate the competency and workmanship of the company responsible for undertaking the work
- the address where the proposed housing is to be installed
- the type of installation proposed to be installed, for example CoMCoP Category 3
- detailed drawings (plan and elevation) of any proposed housing, a second drawing showing the layout of the meter installation (plan and elevation) within such housing and a final drawing showing its proposed location.

The detailed drawings of the housing shall be dimensioned, showing ventilation grilles (including their free area of ventilation), access, emergency access/egress (if required) and the position of all electrical

equipment to be installed and their method of protection for any zone of hazardous area (as determined from any hazardous area assessment).

- supporting documentation, as required, showing the results of any hazardous area assessment undertaken, the method used (IGEM/GM/7B, IGEM/SR/25 etc.) the design calculations for any explosion relief that may be required and the security arrangements that will be in place to stop unauthorised access.

Note: At the time of publication Network approval for meter housing design is managed using GDN/PM/GT2, which is available through the Energy Networks Association (ENA).

SECTION 7 : GENERAL CONSIDERATIONS

7.1 GENERAL

7.1.1 Consideration shall be given (at the design stage) to the degree of security required to prevent unauthorised persons having access to the installation.

Note: All installations require protection from unauthorised access.

7.1.2 Any meter housing/compound shall be locked and any door should be capable of being opened from inside without a key. A set of keys shall be kept in a secure position or under the control of a responsible person. All keys shall be clearly identified by means of labelling in accordance with GS(I&U)R. A label shall be fixed external to the housing/compound and shall indicate the location of keys, for example "Gas Meter House Key at Reception".

7.1.3 Wherever site security personnel are on continuous duty, such authorised officers should control the key or keys to the housing/compound. In any event, authorised personnel shall have a means of access to the installation at all times.

Note: This may be achieved by a dual lock mechanism allowing access by the consumer and other authorised persons using their own keys. This is most likely to be beneficial on large sites where access in an emergency may take longer than desirable.

Keys shall be available at all times.

7.1.4 Any housing/compound should provide adequate security against vandalism.

7.2 SAFETY AND SAFE WORKING ACCESS

7.2.1 Supplied components shall not present a risk to health or safety when properly used by operators during handling, installation and normal use.

7.2.2 Suitable unobstructed access shall be provided to facilitate construction of the installation and its subsequent maintenance.

7.2.3 The site shall be freely accessible for authorised personnel at all times (with permanent safe working access provided irrespective of whether the installation is at high or low level) for:

- reading the meter and, where fitted, the conversion equipment
- adjustment of any regulator
- maintenance
- exchanging the meter
- operation of the ECV, any meter isolation valve and any by-pass valve.

7.2.4 For "non-walk-in" housings (see Figure 2), for example a cupboard or compartment, the whole of the front shall be in the form of a door or easily removable panel.

7.2.5 Where a design incorporates a hinged access roof, it should be fitted with stays to enable it to be held in the open position. The stays should be fitted in pairs and be capable of supporting the weight of the hinged roof while resisting any wind loading that may be applied to the hinged roof while in the open position.

7.2.6 Any "walk-in" or "walk-through" housing (see Figure 2) shall have a minimum internal height of 2.1 m.

- 7.2.7 A meter shall not be located at such a high level that would involve provision of access platforms for reading/installation/maintenance, unless a suitable low level alternative does not exist.
- 7.2.8 A roadway or hard standing should be provided for vehicle access where any meter or equipment is too large, or too heavy, to be manhandled.
- 7.2.9 Consideration shall be given to preventing other parties from impeding access to the site by such acts as the parking of vehicles, the storage of goods and equipment, dumping, etc.
- 7.2.10 The following shall be provided, as required:
- sufficient internal clearances for personnel access and safe working on equipment, also allowing withdrawal of components
- Note: Internal clearance of 0.75 m preferred but a minimum of 0.5 m is acceptable however, significantly more space than this may be required, especially where mechanical lifting equipment has to be used within the housing, and where large/heavy components may need removing on a trolley. It may be beneficial to make use of a removable roof (even when explosion relief is not required) to facilitate easy access to the installation for the removal of major components.*
- where lifting or support equipment is required for safe installation, maintenance or replacement of metering equipment, as appropriate;
 - a lifting beam or suitable runner at high level, appropriately marked to show its safe working load (SWL), and/or
 - access through the roof for mobile gear and/or provision for removing the housing if prefabricated and/or
 - sufficient floor space to enable temporary lifting equipment to be used.
- 7.2.11 Any lightweight lift-off housing/cover shall be capable of easy manhandling by no more than two people (one is preferred). The maximum height to which such a lift-off housing/cover needs to be lifted to clear metering components shall not exceed 1.8 m (see Figure 1).

Note: The recommended maximum weight limit for 2 persons is 40 kg and, for 1 person, 20 kg. However, this is subject to the type of lift. Advice is contained in the HSE publication INDG 143.

Handles, whether fixed or operational, should be positioned for ease of access and operation and be located so that personnel moving a housing/cover are not in danger of walking into equipment under the housing/cover.

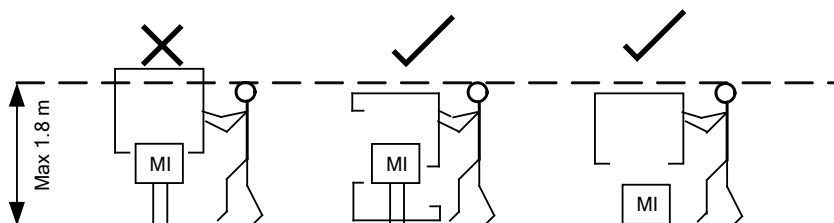

FIGURE 1 - LIFT OFF HOUSINGS/COVERS. EASE OF HANDLING

- 7.2.11.1 Any prefabricated housing/cover or component of weight exceeding 40 kg that requires lifting, either during construction or to facilitate maintenance, shall be fitted with an appropriate number of lifting eyes. Such lifting eyes shall be positioned to facilitate a safe and level lift of the housing/cover or component, in accordance with the requirements of LOLER.
- 7.2.12 Where lifting eyes are fitted, sufficient plugs shall be provided to allow the permanent sealing of the holes if the eyes are to be removed. The sealing method shall ensure that water ingress is permanently prevented.

7.2.13 The design of any lifting eye shall be such that the operation of any explosion relief roof will not be affected if they are not removed.

7.3 **SPACE HEATING**

7.3.1 Where necessary, space heating should be provided to preserve the fabric of the housing and other equipment.

7.3.2 If a heating appliance is to be provided (see IGEN/GM/8 Part 1 and IGEN/GM/7A & B) in a space in which a flammable atmosphere may be present:

- any combustion chamber should be isolated from the space
- the flue shall be vented to a non-hazardous area
- the surface temperature of any component in direct contact with the space should not exceed 350°C.

7.3.3 Any heater shall be appropriately installed and suitable for the hazardous area (see IGEN/GM/8 Part 1 and IGEN/GM/7B).

7.4 **LABELLING**

7.4.1 The housing/compound shall be labelled in accordance with IGEN/GM/8 Part 5.

7.4.2 Any prefabricated housing shall have an identification plate permanently and prominently fixed to the inside of the entrance door or panel, without compromising the housing integrity, giving the following information:

- manufacturer
- date of manufacture
- gross weight of the housing
- roof weight (if removable)
- fixing bolt tightening torque
- ventilation as a % of floor area
- the location of the ventilation.

Note: If the ventilation is in the form of soffit ventilation, this needs to be stated on the plate.

7.4.3 Any lifting eye should be painted red and show the safe working load.

7.5 **DURABILITY**

7.5.1 Any housing, including fixing mechanisms, doors, etc. should be of maintenance-free design, with the exception of door furniture when minor maintenance may be required.

Note: The normal expectation of design life is 20 years.

7.6 **STATUTORY REGULATIONS**

Any purpose-built external meter housing/compound must comply with relevant statutory regulations.

Note: Such housings may have to comply with, for example, the Building Regulations or local by-laws.

Doors or gates of housings or compounds should not open onto a public thoroughfare, where this cannot be avoided, the open door or gate shall not present a hazard or excessive blockage to the thoroughfare.

SECTION 8 : LOCATION

8.1 Any meter must be installed in a position that meets the requirements of GS(I&U)R where those Regulations apply.

8.2 The meter installation shall be sited as close as practicable to the Network pipeline and should be located within the boundary of the consumer's premises.

Note: This will minimise the length of Network pipeline containing gas over which the consumer has no control.

8.3 In determining the location of an installation, consideration shall be given to the following:

- avoiding any of the consumer's hazardous areas
- extent of any hazardous area generated by the installation (see IGEM/GM/7B or IGEM/SR/25, as appropriate)
- unprotected sources of ignition
- the provision of adequate access for maintenance, including the safe use of any plant and equipment, for example lifting gear and vehicles
- preparation of the site, including levelling or terracing of the site at reasonable cost
- the type of property, for example listed building, factory, etc.
- the proximity of underground services, storage tanks and voids
- avoiding overhead cables and services
- the preservation of the environment, including the avoidance of noise
- the Network pipeline being in suitable proximity to all adjacent buildings and structures (see IGEM/TD/3 or IGEM/TD/4)
- preventing gas venting or leakage from equipment on the installation from entering adjacent structures through open windows, air bricks, balanced flues or similar openings
- the impact of any planned alteration or extension of adjacent properties.

Note: Generally, it is preferable for all but small, low pressure, installations to be located in a separate purpose-built structure or compound and, wherever possible, away from main buildings.

8.4 An installation that incorporates pressure reduction equipment shall not be located within a main building or inset meter box unless:

- where $MOP_u \leq 75$ mbar, ventilation is adequate, the environment is suitable for the equipment and the equipment is protected against foreseeable or accidental damage or
- where $MOP_u > 75$ mbar ≤ 2 bar, ventilation is adequate and:
 - the installation is completely isolated from the rest of the building such that any gas escaping from the installation cannot enter the main building
 - any floor, wall or ceiling separating the installation from the rest of the building shall provide the required fire-resistance and be finished with a coating to minimise the passage of gas through any internal surface into the main building or any cavity
 - for new installations the level of fire resistance must meet the requirements of the building Regulations and should provide fire resistance for at least 30 minutes when tested to BS 476-6, -7, -20, -21 and -22, as appropriate
 - particular attention shall be paid to the sealing around ventilation openings, pipes, etc., which pass through any element, for example, floor or wall of the building (see GS(I&U)R).

- the only access to the installation is from outside the main building through outward-opening doors
- ventilation is direct to/from outside and not via the main building
- an explosion relief is provided, which will be either within the doors, by the doors, by a panel in an outside wall, or by the roof. The explosion relief shall not be onto a public thoroughfare.

Where MOP_u of an installation that incorporates pressure reduction equipment exceeds 2 bar, the installation shall be located away from any main building and take into account the hazardous areas generated, see IGEM/SR/25 and IGEM/GM/7B.

- 8.5 Any hazardous area zone created by the installation should not pass outside of the boundary of the consumer's site onto areas readily accessible to the general public.
- 8.6 Any installation shall be protected from the possibility of accidental damage.
- 8.7 The installation shall not be located in the immediate vicinity of any hazardous installation, for example a fuel, paint or chemical store, etc. unless a suitable risk assessment has been carried out and necessary precautions have been taken.
- 8.8 Except with the agreement of the equipment manufacturer, meter installation equipment shall not be installed where the ambient temperature is outside the range specified by the manufacturer.
- 8.9 Any meter installation shall not be subject to extremes of vibration, nor to an excessively moist, corrosive, chemical-laden or dirty atmosphere.
- 8.10 Consideration shall be given to the suitability of the location with respect to the routing and termination of vents.
- 8.11 Any installation should be on a well-drained site, not liable to flooding, and away from any overhead high tension cables and trees.
- 8.12 Where a purpose-designed enclosure is provided, including those within a main building, it shall not be used for purposes other than regulating and metering the gas supply.
- 8.13 A compressor or booster should not be installed in a meter housing unless there is no practicable alternative. If such equipment does have to be fitted in the housing, it shall be suitable for use in the hazardous area zone determined for the meter house or for a Zone 2 area, whichever is the more onerous requirement. In addition, reference shall be made to IGEM/UP/2 and IGEM/UP/6, as appropriate.
- A pre-mix machine shall not be installed in a meter housing.
- 8.14 Where a meter is to be located in or near an underground car park or any other area of high fire risk, due regard shall be given to the requirements of the Building Regulations.

Note: Generally, in such cases, a meter does not constitute a fire risk and is resistant to external fires.

SECTION 9 : VENTILATION OF HOUSINGS

The purpose of ventilation in a meter installation housing is to:

- ensure that minor gas leakage does not cause the atmosphere within the housing to become unsafe
- allow any escape of gas to be smelled or otherwise detected by passers by
- reduce condensation.

9.1 The total effective ventilation area (free area) shall not be less than 2% of the internal floor area of the housing or its notional equivalent and should be equally distributed and disposed at high and low levels around the outside walls.

Note: The notional equivalent floor area is the floor of an imaginary housing to enclose a meter installation which is, in fact, located in a larger open area. For example, in the corner of a factory workshop, wall mounted in a shop, in a boiler house etc. Where only one wall is used, ventilation is to be increased to at least 3% of the internal floor area.

Reference should be made to IGEM/GM/7B to determine any hazardous area classification of the housing.

9.2 Low level ventilators should be positioned 150 mm above the floor. The high level openings should be situated as close as possible below, but not more than 10% of the total height below the roof or ceiling level. Where housings have an apex type roof design, the level of ventilation should be achieved by utilising ridge ventilators. Any ceiling shall not create an unventilated void.

9.3 Where an enclosure is attached to, or is substantially within, a main building but sealed from it (as may be the case for MOP_u exceeding 75 mbar), ventilation shall be direct to outside the building (see Sub-Section 8.4).

9.4 A housing ventilator shall not be located by or near any building air in-take duct, thus minimising the possibility of gas entering any building. A building ventilator shall not be located within 1 m of the hazardous area zone of a meter installation. If there is any doubt about proximity, expert advice should be sought.

9.5 Any ventilator shall be designed and located to prevent persons tampering with the door restraining fixings.

9.6 Ventilation openings shall not be into a hazardous area, for example a consumer-generated hazardous area or the hazardous area surrounding a vent pipe termination or drain hole.

9.7 Where a ventilation duct is used, it shall be in accordance with Building Regulations but, for gas safety reasons, shall not be fitted with a fire damper.

9.8 Any ventilator shall be of non-adjustable type, and should be weatherproof and fire resistant.

Ventilators shall be designed to prevent the ingress of rain and blockage by leaves or snow.

Holes used for the fixing of ventilators shall be fully sealed and designed to ensure that any inner core material will not be exposed to moisture ingress.

- 9.9 Any ventilator should be of a circular or square hole, or louvre, design. The openings in the ventilator should be such that a 9.5 mm diameter sphere cannot pass through.
If the high level ventilator is in the form of a gap(s) between the walls and the roof of the housing, such a gap shall not exceed 9.5 mm.

Note: The hazardous area from this type of ventilation may cause problems with the siting of electrical equipment (see IGEN/GM/7A).

SECTION 10 : THERMAL AND ACOUSTIC INSULATION

10.1 Due account shall be taken of the level of noise emission at all flow and pressure conditions.

Further guidance on the control of noise is given in IGEM/GM/8 Part 1 which should be referenced if noise may be a problem.

Note: The guidance recommends a survey of ambient noise levels be taken before and after a meter installation becomes operational.

10.2 Consideration shall be given to the measures necessary to reduce any nuisance due to noise, which may be emitted by the installation.

10.3 Consideration shall be given to the provision of thermal and acoustic insulation for housings and buildings.

Note: In particular, this is relevant to installations of MOP_v ~~not~~ exceeding 75 mbar.

10.4 Ventilation design should take account of the acoustic properties of the building.

10.5 Where a baffle or other design of acoustic ventilation panel is provided within or behind a ventilator, the free area of the aperture should be increased to maintain the required performance of the ventilation system.

SECTION 11 : CONSTRUCTION AND MATERIALS FOR HOUSINGS

Housings are defined as “non-walk-in”, “walk-in (via one side)”, “walk-in” (via two or more sides)” and “walk-through”. Reference should be made to Figure 2.

11.1 DESIGN

11.1.1 All housings

11.1.1.1 The materials used in the construction of any housing/compound shall provide:

- low maintenance requirements
- sound insulation, where necessary
- durability
- security
- weather resistance
- fire resistance.

11.1.1.2 Where pipes are to enter and leave a housing above floor level, and unless a sleeve or single skin panel has been fitted during construction/manufacture of the housing, the circular holes required should be made, using a suitable tool, for example a core drill, at the pipe entry and exit points to accommodate both pipe and sleeve. The annular space between the pipe and sleeve and between the sleeve and the housing wall shall be sealed with an appropriate fire resistant mastic sealant.

11.1.1.3 Any opening in a housing should be restricted only to those for doors, ventilation, explosion relief, pipework and ancillary services.

Any door or ventilation aperture should be located at a safe distance from any window, door or aperture of another building.

It should not be possible to create a path for air movement between a space containing a meter installation and another space that contains an ignition source, for example by opening an access door, unless the ignition source is at a safe distance or is suitably protected.

11.1.1.4 If access is required on more than one side of the installation, at least two access points shall be provided, each with an adequate and safe means of escape in an emergency (see Figures 2(c) and (d)).

11.1.1.5 There should not be any aperture connecting with another closed space. In particular, the space containing a meter installation shall not be connected directly to a sewer, for example by a floor drain, or any other below ground service duct.

11.1.1.6 Metal items manufactured from aluminium-based light metals, for example door furniture, protection strips etc. should be used only if the magnesium content does not exceed 6% by weight.

Such items shall be protected against galvanic action occurring where contact with steel is likely to occur.

11.1.1.7 Where instrument panel boards or safe area compartments are required, they should be prefabricated for GRP housings to the customer’s specification or, where not specified, be of a standard design.

Note: A typical design would be exterior-grade 18 mm plywood sandwich construction of dimensions 450 mm wide x 300 mm deep x 600 mm high, positioned centrally on one of the walls designated as the width of the housing.

For other housings, the method of fixing panels and components to interior walls shall be such that the integrity of the housing is not impaired.

11.1.1.8 Earthing of any metallic structure shall be in accordance with IGEM/GM/8 Part 1.

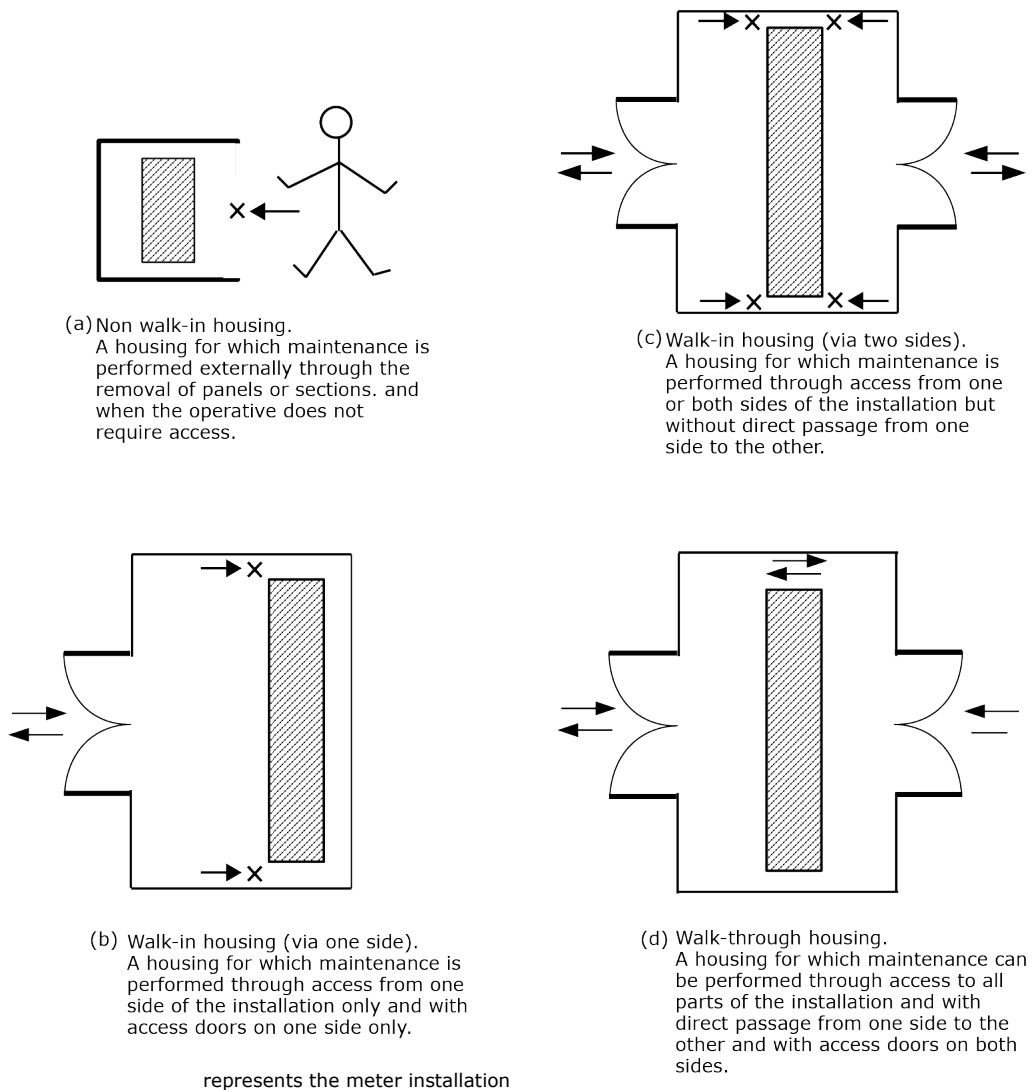

FIGURE 2 - ACCESS CLASSIFICATION

11.1.2 **Glass Reinforced Plastic (GRP) housings**

11.1.2.1 Pipework shall not enter or exit the housing through the side walls unless the facility has been specifically provided to enable removal of the housing, for example keyhole slots and infill panels.

Note: These are usually located at high level and at each end of the housing.

11.1.2.2 The skin should be resin bonded and be of either a single skin or sandwich construction which is cavity-free. Corners, door frames and base frames should be strengthened. Any sandwich structure shall be formed from resin bonded glass fibre inner and outer skins totally encapsulating a suitable core material and meet the criteria and tests in Appendix 4.

11.1.2.3 The thickness of the gel coat layers shall be in the range recommended by the gel coat manufacturers.

11.1.2.4 Fixing methods that interrupt the continuity of the GRP surface shall be fully sealed to ensure that ingress of moisture does not occur.

11.1.2.5 Where a framework is used, it shall be of wooden or metal construction, suitably treated such that it will attain the required design life. The framework shall be adequate to support the structure.

All wooden joints shall be glued using appropriate timber adhesives and screwed, and all metal joints suitably welded to attain the required design life.

The framework shall be totally encapsulated within the GRP structure.

Note: Other materials may be considered to be suitable provided that they meet the tests in Appendix 4.

11.1.2.6 Prefabricated safe area compartments shall be internally moulded/attached, projecting into the housing but completely sealed from it.

Access shall be through an external outward-opening door attached to the main housing.

It shall be possible to mount logging and conversion equipment within the compartment such that it is totally isolated from the main housing.

Note: A safe area compartment is not intended to contain instruments that carry fuel gas.

11.1.2.7 The design of the compartment shall be such that all cables have to be routed into the compartment from outside the main GRP housing, without compromising the integrity of either the compartment or the housing.

Note: This is to ensure there is no relief ingress of gas in the safe area compartment.

11.1.2.8 All cables and glands shall be matched so as to prevent the ingress of gas or water into the safe area compartment.

The IP ratings of the external door shall be to BS EN 60529, at least IP 65.

The safe area compartment shall not be fitted to the same wall as a relief vent pipe.

11.2 FOUNDATIONS, BASES AND FLOOR MOUNTING

11.2.1 All housings/compounds

11.2.1.1 Suitable foundations, generally of the slab (raft) or footing type, shall be provided. They shall be designed to take account of any special features of the site, for example, subsidence, local infill, clay, etc., and shall make adequate provision for pipes to enter and leave the housing.

11.2.1.2 Foundations, bases and floors shall be constructed in accordance with appropriate standards such as BS EN 1997, BS 8500-1, BS 8500-2 and BS EN 1992-1-1.

Note: Typically, a slab may be cast on a well compacted BS EN 13285 C90/3 (MOT Type-1) crushed sub-base with concrete specified to BS 8500, minimum cement content 380 kg per m³ sulphate resisting Portland cement, with reinforcing to BS 4483, with cover at least equal to the largest aggregate size.

11.2.1.3 Floors and duct coverings shall be strong enough to take the required point weight loadings of the installation and any additional loadings imposed during construction and maintenance.

11.2.1.4 All base fixing points shall be inside the housing, to prevent unauthorised removal once installed.

11.2.1.5 The design and location of the fixing points shall ensure that accidental stress loading during installation is spread over the body of the housing.

11.2.2 **Prefabricated housings (including GRP)**

Sufficient restraining bolts and washers shall be supplied by the housing manufacturer so that, once installed, the housing will meet specified wind loading.

Note: Normally, at least size M10 bolts and washers will be required.

11.2.3 **GRP housings**

11.2.3.1 The base flange shall be suitably reinforced and shall be provided with an appropriate number of fixing holes. The fixing holes shall be incorporated into the fabric of the base flange during construction. The pitch of the fixing points shall not exceed 1000 mm.

11.2.3.2 The laminate on the underside of the base flange shall have a thickness of not less than 6 mm and be suitably protected to prevent damage to its weatherproofing, in the event of the surface being abraded during installation of the housing.

11.2.3.3 Where the housing is designed to fit onto a concrete base, suitable flexible sealant shall be provided to seal the base to the concrete standing. The sealing kit shall include fitting instructions and detail any safety precautions that may be required.

Note: Lift-off housings may have an alternative method of base fixing, allowing for ease of removal without damaging the housing.

11.3 **DOORS**

11.3.1 Doors shall conform to BS 459 (wood) or BS 6375 (steel) or an equivalent standard and shall be designed so that warping is minimised during weathering and minor deviations from square during installation will not cause the door to stick. The design shall ensure that rainwater is prevented from entering.

11.3.2 The design of any door and the door access or housing shall be such as to prevent any direct line of sight into the housing when the door is closed.

11.3.3 At least three hinges should be provided on doors 2 m or greater in height, located within 300 mm of top and bottom of the door and the other centrally. Alternatively, a continuous strip-type hinge may be utilised. Housings with doors less than 2 m in height shall have at least two hinges fitted.

The hinge design should ensure that any hinge-securing bolts can only be removed from inside the housing or be totally concealed when the door is in the closed position.

Hinges shall be constructed of corrosion-resistant metal and designed so that differential corrosion is minimised.

11.3.4 Where an explosion relief is incorporated into the roof or walls of the housing, the doors and locking mechanism shall be strong enough that an explosion would not cause the doors to open (see Section 14).

- 11.3.5 Each door for a “walk-in” or “walk-through” housing shall have a minimum nominal width of 800 mm and a minimum height of 2 m.
- 11.3.6 Outward opening doors, of sufficient size to afford access to persons and equipment, shall be provided on the outside wall to accommodate installation and maintenance work.
- 11.3.7 For a “walk-through” housing, an additional emergency exit shall be provided on the opposite side of the building to the main doors (see Figure 2(d)).

For a “walk-in” housing, at least one set of standard width outward-opening double doors shall be fitted. Two sets of standard width doors are preferred, which should be mounted on opposite ends of the housing for rapid exit in the case of emergency (see Figure 3).

Note: This is to provide an alternative means of escape.

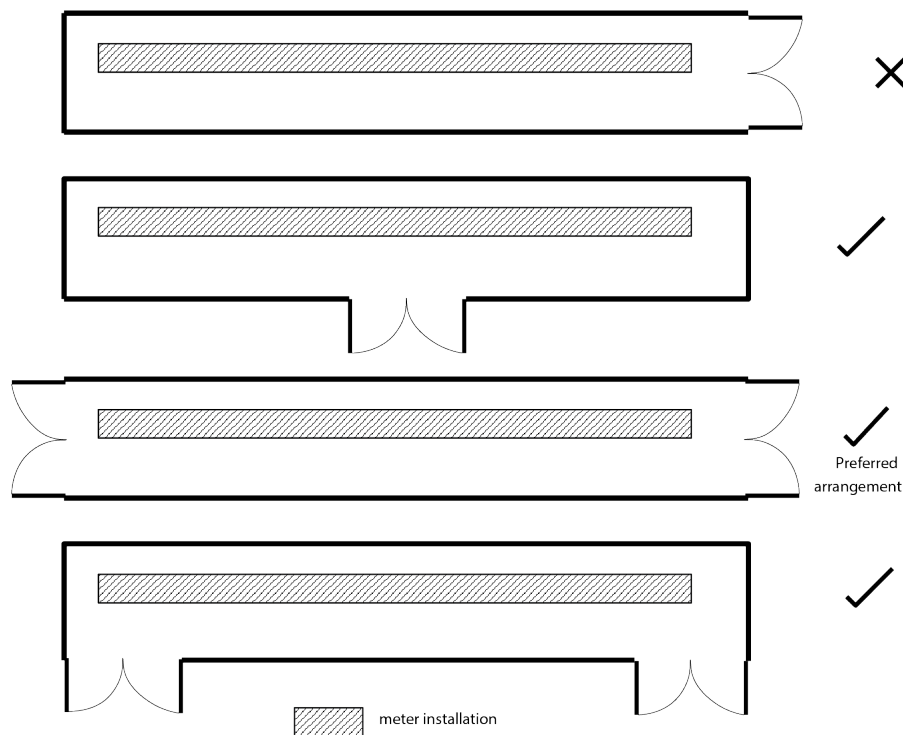

FIGURE 3 - PROVISION OF EXITS IN LONG “WALK-IN” HOUSINGS

- 11.3.8 Any means of escape shall be readily operable from inside without the aid of a key.
- 11.3.9 Doors shall be capable of being fully opened to approximately 180° and should be held back in that position.
- 11.3.10 In addition all doors should be fitted with a restraining device to secure the door open to 90° and be manually reset.
- 11.3.11 For a housing of the cupboard or compartment type, the whole front shall be in the form of a door or an easily removable panel.
- 11.3.12 For a separate room attached to a building, at least one set of standard width outward-opening double doors shall be fitted to the outside wall.

Where only one set of doors is provided, the meter shall be positioned such that it is accessible for maintenance and reading the meter from the side facing the doors only.

- 11.3.13 The left-hand door of the double doors designated "front" shall be secured internally.
- 11.3.14 The right-hand door of the double doors designated "front" should be secured by means of a hasp and staple to accept a security lock or other, alternative equivalent means of securing with a minimum diameter of 12 mm. The hasp should be positioned at the left-hand edge of each right-hand door when viewed externally and centrally located.
- 11.3.15 The double doors designated "rear" on "walk-through" housings shall be secured internally to an equivalent standard as the front doors, and shall only be capable of being opened from the inside and without a key.
- 11.3.16 Any double doors designated "rear" on "walk-in" housings (see Figure 2 (c)) shall be secured in the same manner as the front doors.
- 11.3.17 Any single door on a "walk-in" housing shall be secured externally.
- 11.3.18 Any rear door used for escape in an emergency shall not be capable of being padlocked.
- 11.3.19 Shooting bolts and locking bars shall locate at the top and bottom of the left hand doors, either behind the door frame against keeper plates or within a suitable, strengthened, sill.
- 11.3.20 Where door sills are fitted, they should be a maximum of 10 mm in height and shall be of corrosion-resistant material.

11.4 **WALLS**

11.4.1 **All housings**

- 11.4.1.1 Where a new, purpose-built room or building is provided to house an installation, the walls shall be solid without cavity and shall not include openings other than those required for access, ventilation, pipework or other ancillary services.
- 11.4.1.2 Where a new housing makes use of existing walls of cavity construction, those parts of the wall bounding the new housing shall provide the required fire resistance and be finished with a coating to minimise the passage of gas through the wall or into the cavity.
- 11.4.1.3 If an additional room is built onto a housing which may contain potential sources of ignition, the adjoining wall shall be finished with a coating to minimise the potential for gas leakage through the wall.
- 11.4.1.4 For a brick-built building, and where an explosion relief is required, the walls should be a minimum 225 mm thick with the bricks fully interlocking. Piers or returns should be provided on long walls.

The design of any damp proof course should be such as to prevent any tendency for the wall to slide off the damp proof material in the event of an explosion.

- 11.4.1.5 Any wall shall be designed as necessary to withstand specified wind loading.

11.4.2 **Prefabricated housings (including GRP)**

- 11.4.2.1 Where a housing is of sectional construction, the walls shall be fully formed. The joints shall be positioned to give maximum strength to the housing, and shall be suitably protected and sealed with flexible sealant. Walls shall not contain cavities.
- 11.4.2.2 Where wall core material is fixed to the frame by means of a lap joint, the depth of the joint shall not be less than two thirds of the thickness of the frame.
- 11.4.2.3 Butt joints shall not be used to form corners or openings.
- 11.4.2.4 For a GRP housing, clearly defined relief vent panels should be incorporated into the walls, through which relief vent pipes may pass. The panels should be located centrally in the horizontal plane of the wall, and 100 mm below soffit level.

Note: Panel dimensions of 700 mm long by 100 mm high are normally sufficient.

The panels shall consist of solid GRP with no core material, but with any decorative finish to match the rest of the housing, and may incorporate appropriate pre-drilled and plugged holes.

11.5 **ROOFS AND LIFT-OFF PANELS**

- 11.5.1 The roof of any purpose-built external housing:
- should be of lightweight construction, or so constructed to minimise damage to installed equipment in the event of a roof fall
 - should provide the same level of security as the rest of the structure, unless other overall site security measures are taken
 - shall not enclose any unventilated void
 - should be of fire-resistant material.
- 11.5.2 In circumstances where the roof is not required to act as an explosion relief, it shall be securely attached to the walls.
- Note: It is beneficial that the whole or part of the roof is removable in order to facilitate access to the installation.*
- 11.5.3 The roof shall be strong enough to be walked upon safely and be designed to withstand loads imposed by wind, snow, etc.
- 11.5.4 The roof shall be waterproof and shall project sufficiently over the walls as to prevent water entering the ventilators.
- 11.5.5 The roof shall have a minimum fall (gradient) of 1:60 in order to prevent water holding on the roof. Arrangements shall be made to allow rainwater to be shed away from the door access areas and any safe area compartment.
- 11.5.6 Lift-off panels and hinged roofs on small housings shall be secured by suitable locking mechanisms.
- 11.5.7 Hinged access roofs shall have hold open stays that resist the wind loading (see clause 7.2.5).

11.6 **FINISH**

- 11.6.1 The finish of any housing should allow the removal of graffiti without suffering any damage to coating materials and should be smooth or textured, normally

BS 4800 green 14-C-39 equivalent to RAL160 40 15 or, alternatively, stone, brick or cement rendering or another colour.

11.6.2 The finish shall resist the effects of ultraviolet (UV) light to ensure minimal degradation over its design life.

Note: For a GRP housing, this will involve UV stabilisation.

11.6.3 The internal finish of any GRP or other prefabricated housing should be white.

11.7 PERFORMANCE

11.7.1 All housings

11.7.1.1 Any housing shall withstand wind speeds of 50 m s⁻¹.

11.7.1.2 The roof of the housing shall withstand a uniformly distributed load of 1.25 kN m⁻². Compliance should be verified either by design calculations or by an appropriate test method.

11.7.2 GRP housings

11.7.2.1 Housings shall suffer no defects due to temperatures within the ambient temperature range -20°C to +50°C.

11.7.2.2 Any housing shall meet the performance test specifications given in Appendix 4.

11.8 FIRE RESISTANCE

11.8.1 All combustible materials used in the construction of the external surface shall have a fire performance in accordance with clauses 11.8.2 and 11.8.3.

Note: GRP housings are regarded as combustible and therefore need to be tested in accordance with this section.

11.8.2 When tested to BS 476-12, utilising flame "Source G", 500 mm x 750 mm there shall be no holes formed in any of the tested specimens when the flame is applied for 3 minutes. The sample shall retain its physical strength which shall be demonstrated by compliance with the impact test specified in Appendix 4. Following the test there shall be no holes formed in the panel.

11.8.3 When a large representative section of the housing (1000 mm x 1000 mm) is tested (in the vertical orientation) to BS 476-12, utilising flame "Source E" for a period of 20 minutes, the sample:

- shall show no signs of penetration, and
- the extent of damage shall be limited to an area no wider than 550 mm, and
- the flames shall self extinguish within 5 seconds of the "Source E" being extinguished.

Note 1: A kiosk approximately 1 m x 0.54 m x 0.96 m, may be used as an alternative to a test panel.

Note 2: The flame source is to be positioned such that it is approximately 25 mm from the surface of the test panel, and impinges on the face of the test panel at an angle of 45° at a point approximately 100 mm from the base of the panel.

SECTION 12 : OUTDOOR COMPOUNDS

- 12.1 The installation should be securely fenced-off. Where a site security fence is used that incorporates spikes, barbed wire, etc, the spikes/barbs should be at a sufficient height as to minimise the risk of accidental injury to staff or passers-by (a minimum height of 2.4 m is recommended). The compound fencing shall provide adequate access (e.g., for persons, equipment, vehicles, etc.) to the installation for repair, maintenance and fire-fighting.
- 12.2 When determining the size of a compound and the location of equipment within it, due consideration shall be given to the extent of any hazardous area and, providing safe working access, including adequate allowance for the use of mechanised lifting equipment and vehicles.
- 12.3 Where a roadway is provided within the installation compound to facilitate access for maintenance, the installation should be laid out parallel with, and adjacent to, the roadway. Any pipework should be at least 2 m from the roadway.
- 12.4 Consideration shall be given to the provision of vehicle barriers to protect the installation and the fitting of protective covers to vulnerable equipment where it is necessary to guard against vandalism.
- 12.5 Floodlighting, from positions situated at a safe distance from any hazardous area, shall be considered.
- 12.6 Equipment shall be sited at a sufficient distance from the perimeter of the compound to prevent interference from outside and, for electrical equipment, this distance should be at least 2 m. If less, pipework and compound fencing shall be fitted with an equipotential bond.
- Note: The risk of potential vandalism will need to be considered on a site-specific basis.*
- 12.7 Gates shall be provided of sufficient size to afford access to persons and equipment for installation and maintenance. These gates should be outward-opening but, where inward-opening or sliding gates are used, sufficient space shall be provided on the inside of the compound to ensure that the emergency exits are not obstructed and access to the installation is not restricted.
- 12.8 Where access is required around the installation, an additional gate, for use in an emergency, shall be mounted on an opposing side of the compound. Any emergency exit shall be readily operable from inside without the aid of a key. The means provided shall not be readily operable from outside the compound.
- 12.9 The gates shall be capable of being fully opened to approximately 180°.
- 12.10 Means shall be provided to retain any gate in the fully open position.
- 12.11 A suitable method shall be provided for locking the compound.
- 12.12 Where only one set of gates are provided into a compound, the meter shall be positioned such that it is accessible for maintenance and meter reading from the side facing the gates.

SECTION 13 : PITS

13.1 GENERAL

13.1.1 Equipment should not be located in a pit unless there is no practicable alternative.

13.1.2 Any pit shall be of robust construction and designed to withstand foreseeable superimposed loads and forces exerted by ground water. It shall be watertight and provide adequate security against vandalism.

Any construction material subject to corrosion should be protected fully prior to in-ground installation.

13.1.3 Any pipe and conduit passing through the walls of a pit shall be sleeved and the annulus sealed to maintain a gas tight and watertight seal.

13.1.4 The dimensions of any pit shall be such that operatives can carry out maintenance work safely and effectively. Where a pit is defined as a confined space, the pit must be designed to facilitate compliance with the Confined Space Regulations.

Any volume that, potentially, could be occupied by an air/gas mixture shall be kept to the minimum possible, consistent with reasonable access by operatives.

13.1.5 The maximum depth of any pit should not exceed 1.25 m. In any event, any operative undertaking maintenance work shall be able to have head and shoulders above the level of the surrounding ground.

13.1.6 A permanent ladder or steps shall be provided for access to any pit having a depth greater than 750 mm.

13.1.7 Where appropriate, a sump shall be constructed in the base of any pit.

13.1.8 Any pit shall not be connected, by an open duct or pipe, with a drain or other enclosed space.

13.1.9 Where any pit is covered, provision shall be included to enable testing of the pit atmosphere prior to opening the pit and for purging the pit.

13.2 VENTILATION

13.2.1 Internal volume $\leq 0.5 \text{ m}^3$

The cover of the housing shall incorporate a ventilation area of not less than 6% of the floor area of the pit and should not be airtight. Ventilator design should prevent the ingress of water.

13.2.2 Internal volume $> 0.5 \text{ m}^3$

13.2.2.1 The ventilation area shall be not less than 3% of the floor area of any pit for volumes up to 1.5 m^3 and not less than 2% for larger volumes.

13.2.2.2 A two-pipe ventilation system shall be installed with ventilation ducts starting at both high and low levels within any pit. These should terminate at least 3 m above ground level (see Figure 4).

13.2.2.3 The ventilation duct starting at high level within any pit shall terminate at least 1 m above the other duct.

Where a ventilation duct terminates at less than 3 m above ground level, flame arrestors shall be fitted when the effective area shall not be decreased.

13.2.2.4 Ventilation ducts shall be suitably protected against the ingress of rain, leaves, etc. Such protection shall not restrict the effective ventilation area.

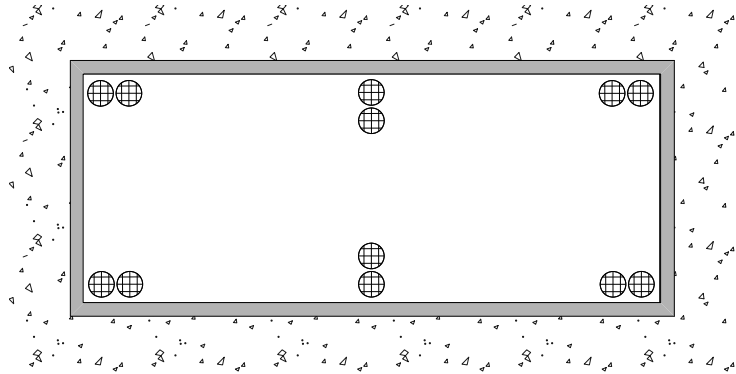

FIGURE 4(a) - Typical arrangement of vent stacks (plan view). Total number will depend on pit floor area

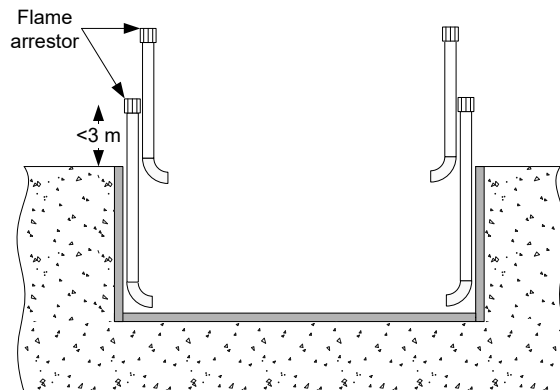

FIGURE 4(b) - Vent stacks terminating lower than 3 m. Fitted with flame arrestors

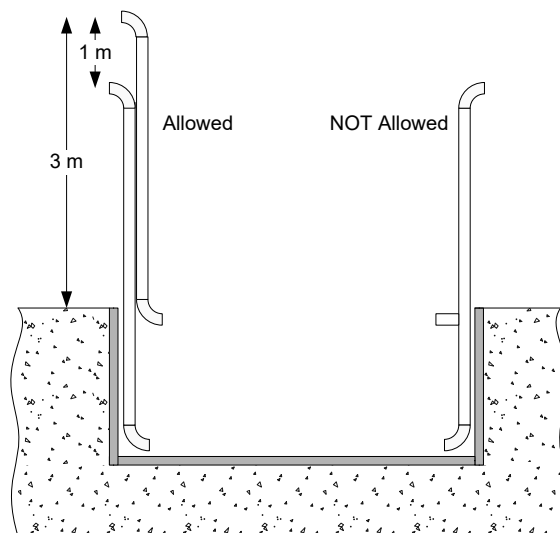

FIGURE 4(c) - Permitted and not permitted combinations of vent ducts

FIGURE 4 - TERMINATION OF VENTILATION DUCTS FROM A PIT

13.3 **PIT COVERS**

13.3.1 Any pit cover shall be designed to withstand foreseeable imposed loads.

13.3.2 It should be possible to remove the whole or part, as required, of any cover during maintenance work. The cover (or section of cover) should be designed such that no more than two people are required to remove it (one person is preferred), otherwise a mechanical means of removing the cover should be provided.

13.3.3 The arrangements for raising and lowering any cover shall be such as to protect the installed equipment from damage due to a handling error.

13.3.4 Any handle, whether fixed or operational, should be positioned for ease of access and operation and be located so that personnel moving any cover will not be in danger of walking into pits or equipment under the cover.

Note: Where the design adopts a removable handle, provision may be made in the cover design so that removable handles can be stored inside a lockable compartment attached or adjacent to the cover.

13.3.5 Any cover should be durable, fire resistant and weather resistant and should require the minimum of maintenance.

13.3.6 The profile of the top of any cover should be such that surface water is directed away from the pit. Where more than one cover is required to cover a pit, provision for surface water collection, and subsequent dispersion, should be incorporated into the design.

13.3.7 Where the design requires the provision of strengthening or support bars spanning across a pit, they should be removable to allow full access for maintenance of gas equipment.

13.3.8 Any lift-off pit cover should be secured by means of a hasp and staple to accept a security lock with a staple diameter of 12 mm. Alternatively, a suitable locking mechanism may be incorporated into the design.

13.3.9 Locks shall be provided on two opposite sides.

SECTION 14 : EXPLOSION RELIEFS

- 14.1 Where a housing is of internal volume 1.5 m³ or greater, an explosion relief shall be provided, unless the volume is classified as Zone 2, 2NE or a safe area.
- For additional information on the hazardous area assessment of housings, reference should be made to IGEM/GM/7B or IGEM/SR/25.
- 14.2 Irrespective of the size of housing or hazardous area classification, the provision of an explosion relief shall be considered in exceptional cases, for example where an explosion in a meter housing may impair the structural integrity of a main building.
- 14.3 Any explosion relief shall be capable of relieving the effects of an explosion while preventing damage to a building.
- 14.4 Any explosion relief would, normally, be provided by the roof of the housing lifting. However, where circumstances permit the use of an explosion panel within the roof, the discharge area shall not be less than 50% of the area of the roof.
- Alternatively, an explosion relief can be provided by the door or panel in an outside wall. However, in any case, the explosion relief shall not be onto a public walkway.
- 14.5 Any explosion relief shall be designed to limit the maximum internal pressure developed during an explosion to 35 mbar or less and not fragment or become detached from the rest of the structure when operated.
- 14.6 Where an explosion relief is provided by the roof of a housing lifting, the roof restraining fixings and mechanism shall be contained within the building and shall be so designed to allow vertical movement, but limit lateral movement. The operation of the explosion relief shall not damage the walls of the housing.
- The explosion relief shall be designed to re-seat in its original position and prevent damage to equipment within the housing following operation.
- 14.7 Any housing fitted with an explosion relief shall be capable of withstanding the maximum internal pressure developed during an explosion and designed such that there would not be any fragmentation and should be designed such that the doors remain firmly attached and fastened.
- 14.8 In order to operate effectively, any explosion relief shall not be obstructed, either on the inside or the outside of the housing. Similarly, any vent pipe, ventilation duct, vent stack or vent line should not pass through an explosion relief.
- 14.9 Any cables and lighting provided within a housing shall not interfere with the action of any explosion relief panel or roof.

Note: For further guidance on the design of explosion reliefs in roofs, see Appendix 3.

SECTION 15 : LIGHTNING CONDUCTORS

- 15.1 Consideration shall be given to protecting exposed installations against lightning, by suitably positioned lightning conductors. For further guidance, BS EN 62305 should be consulted.
- 15.2 Reference should be made to IGEM/GM/8 Part 1 or IGEM/GM/7A and B.

APPENDIX 1 : GLOSSARY, ACRONYMS, ABBREVIATIONS, UNITS AND SYMBOLS

A1.1 GLOSSARY

All definitions are provided in IGEM/G/4, which is freely available by downloading a printable version from IGEM’s website www.igem.org.uk.

Standard and legacy gas metering terms are given in IGEM/G/1, which is also freely available to download and print from IGEM’S website www.igem.org.uk.

A1.2 ACRONYMS

ACoP	Approved Code of Practice
ACS	Nationally Accredited Certification Scheme for Individual Gas Fitting Operatives
AMI	approved meter installer
BSI	British Standards Institution
CDM	Construction (Design) Management Regulations
CoMCoP	Consolidated Metering Code of Practice
COSHH	Control of Substances Hazardous to Health Regulations
DSEAR	Dangerous Substances and Explosive Atmospheres Regulations
ECV	emergency control valve
ENA	Energy Networks Association
ESP	emergency service provider
GB	Great Britain
GDN	Gas Distribution Network
GRP	glass reinforced plastic
GS(I&U)R	Gas Safety (Installation and Use) Regulations
GS(M)R	Gas Safety (Management) Regulations
GT	gas transporter
HSE	Health and Safety Executive
HSWA	Health and Safety at Work, etc. Act
IP	ingress protection
IGEM	Institution of Gas Engineers and Managers
LOLER	Lifting Operation and Lifting Equipment Regulations
MAM	Meter Asset Manager
MHSWR	Management of Health and Safety at Work Regulations
MIP	maximum incidental pressure
MOP	maximum operating pressure
NG	Natural Gas
Ofgem	Office of Gas and Electrical Markets
OP	operating pressure
PSSR	Pressure Systems Safety Regulations
PUWER	Provision and Use of Work Equipment Regulations
RD	rotary displacement
REC	Retail Energy Code company
RIDDOR	Reporting of Injuries, Diseases and Dangerous Occurrences Regulations
SWL	swing weight load
UIP	utility infrastructure provider
UK	United Kingdom
UKAS	United Kingdom Accreditation Service
USM	ultrasonic meter
UV	ultra violet.

A1.3 UNITS AND SYMBOLS

kN	kiloNewton
kN m ⁻²	kiloNewton per square metre
ph	measure of how acidic/basic of an aqueous solution is
°C	degrees Celsius
°	degree angular
%	percentage
<	less than
≤	less than or equal to
>	greater than
-	minus
+	plus
±	plus or minus.

A1.4 SUBSCRIPTS

u = upstream.

APPENDIX 2 : REFERENCES

This Standard is set out against a background of legislation in force in GB at the time of publication. Similar considerations are likely to apply in other countries and reference to the appropriate national legislation will be necessary. The following list is not exhaustive.

Where British Standards, etc. are quoted, equivalent national or international standards, etc. equally may be appropriate.

Care is to be taken to ensure that the latest editions of the relevant documents are used.

A2.1 **LEGISLATION**

This sub-appendix lists legislation referred to in this Standard as well as legislation not referenced but which may be applicable.

- Building Regulations 2010 as amended 2016
- Building Regulations 2010 (Wales) as amended 2016
- Building Standards (Scotland) Regulations (Amendment) 2001 and Amendments 2002, as amended
- Building Regulations (Amendment) Act (Northern Ireland) 2009
- Confined Spaces Regulations 1997
- Construction (Head Protection) Regulations 1989
- Construction (Design and Management) Regulations 2015
- Construction (Health, Safety and Welfare) Regulations 1996
- Control of Asbestos Regulations 2012
- Control of Noise at Work Regulations 2005
- Control of Pollution Act 1974, as amended
- Control of Substances Hazardous to Health Regulations 2002, as amended
- Dangerous Substances and Explosive Atmospheres Regulations 2002
- Electricity at Work Regulations 1989 and Memorandum of Guidance 1989
- Environment Act 1995
- Environment Act 2021
- Environmental Protection Act 1990
- Gas Act 1986 (as amended by Gas Act 1995 and incorporating stand-alone provisions of the utilities act 2000)
- Gas (Calculation of Thermal Energy) (Amendment) Regulations 2015
- Gas (Meter) Regulations, 1983
- Gas Safety (Installation and Use) Regulations 1984; 1994, as amended; 1998, as amended
- Gas Safety (Management) Regulations 1996, as amended
- Health and Safety at Work etc. Act 1974, as amended
- Lifting Operations and Lifting Equipment Regulations 1998
- Management of Health and Safety at Work Regulations 1992, as amended
- Manual Handling Operations Regulations 1992
- Measuring Instruments (EEC Requirements) (Gas Volume Meters) (Amendment) Regulations 1979, as amended
- Noise and Statutory Nuisance Act 1993
- Noise at Work Regulations 2005
- Personal Protective Equipment at Work Regulations 1992, as amended

- Pipelines Safety Regulations 1996, as amended
- Pressure Equipment (Safety) Regulations 2016
- Pressure Systems Safety Regulations 2000
- Provision and Use of Work Equipment Regulations 1998
- Reporting of Injuries, Diseases and Dangerous Occurrences Regulations 2013
- Town and Country Planning Act 1990
- Transport Act 2000
- Workplace (Health, Safety and Welfare) Regulations 1992.

A2.2

HSE ACOPs and GUIDANCE

- EH40 Occupational exposure limits. Guidance
- HSG6 Avoidance of danger from overhead electric power lines. Guidance
- HSG47 Avoiding danger from underground services. Guidance
- HSG48 Reducing error and influencing behaviour. Guidance
- HSG224 Managing Health and Safety in Construction. Construction (Design and Management) Regulations. ACoP and Guidance
- HSG227 A comprehensive guide to managing asbestos in premises
- HSG253 Safe Isolation of Plant
- L21 Management of Health and Safety at Work. ACoP and Guidance
- L22 Safe Use of Work Equipment. ACoP and Guidance
- L56 Safety in the Installation and Use of Gas Systems and Appliances. ACoP and Guidance
- L73 Reporting of Injuries, Diseases and Dangerous Occurrences Regulations. Guidance
- L80 Gas Safety (Management) Regulations. Guidance
- L113 Safe use of lifting equipment. ACoP and Guidance
- L122 Pipelines Safety Regulations. Guidance.
- L138 Dangerous Substances and Explosive Atmospheres Regulations 2002. ACoP and Guidance
- L153 Construction (Design and management) Regulations 2015. ACoP
- HSR25 Electricity at Work Regulations. Guidance
- INDG 143 Manual handling at work - A brief guide
- INDG 178 Written Schemes of Examination
- INDG223 A short guide to managing asbestos in premises
- INDG 229 Using Work Equipment Safely
- INDG 261 Pressure Systems – safety and you
- INDG 291 Simple guide to the Provision and Use of Work Equipment Regulations
- INDG 370 Fire and explosion; How safe is your workplace? A short guide to the Dangerous Substances and Explosive Atmospheres Regulations 2002
- INDG 453 RIDDOR reporting

A2.3

INSTITUTION OF GAS ENGINEERS AND MANAGERS

- IGEM/G/1 Edition 2 Defining the end of the Network, a meter installation and installation pipework
- IGEM/G/4 Edition 2 Definitions for the gas industry
- IGEM/G/11 Edition 2 Gas Industry Unsafe Situations Procedure
- IGEM/GM/4 Edition 3 Flow metering practice for pressures between 38 and 250 bar
- IGEM/TD/4 Edition 5 PE and steel gas services
- IGEM/GM/6 Edition 3 Specification for low pressure diaphragm and rotary displacement meter installations with badged meter capacities exceeding $6 \text{ m}^3 \text{ h}^{-1}$ ($212 \text{ ft}^3 \text{ h}^{-1}$) but not exceeding $1076 \text{ m}^3 \text{ h}^{-1}$ ($38000 \text{ ft}^3 \text{ h}^{-1}$)
- IGEM/GM/7A Edition 2 Electrical connections gas metering equipment
- IGEM/GM/7B Edition 2 Hazardous area classification for gas metering equipment
- IGEM/GM/8 Part 1 Ed 3 Non-domestic meter installations. Flow rate exceeding $6 \text{ m}^3 \text{ h}^{-1}$ and inlet pressure not exceeding 38 bar. Design
- IGEM/GM/8 Part 3 Ed 3 Non-domestic meter installations. Flow rate exceeding $6 \text{ m}^3 \text{ h}^{-1}$ and inlet pressure not exceeding 38 bar. Installation and commissioning
- IGEM/GM/8 Part 4 Ed 3 Non-domestic meter installations. Flow rate exceeding $6 \text{ m}^3 \text{ h}^{-1}$ and inlet pressure not exceeding 38 bar. Operation and maintenance
- IGEM/GM/8 Part 5 Ed 3 Non-domestic meter installations. Flow rate exceeding $6 \text{ m}^3 \text{ h}^{-1}$ and inlet pressure not exceeding 38 bar. Notices and labels
- IGEM/SR/25 Edition 2 Hazardous area classification of Natural Gas installations
- IGEM/IG/1 Edition 2 Standards of training in gas work.

A2.4

BRITISH STANDARDS (abbreviated titles)

- BS 459 Match boarded wooden door leaves
- BS 476 Fire tests on building materials and structures
- BS 476-6 Tests for fire propagation for products
- BS 476-7 Tests to determine classification of the surface spread of flame products
- BS 476-12 Tests for ignitability of products by direct flame impingement
- BS 476-20 Determination of the fire resistance of elements of construction
- BS 476-21 Determination of the fire resistance of load bearing elements of construction
- BS 476-22 Determination of the fire resistance of non-load bearing elements
- BS 4800 Paint colours for building purposes
- BS 6375 Performance of windows and doors - Classification for weathertightness and guidance on selection and specification

- BS 6400-1 Domestic sized meter installations – low pressure Natural Gas
- BS 6400-2 Domestic sized meter installations – medium pressure Natural Gas
- BS 8004 Foundations
- BS 8500 Concrete
- BS EN 596 Timber structures. Test methods
- BS EN 437 Test gases
- BS EN 1992 Eurocode 2. Design of concrete structures - General rules and rules for buildings, bridges and civil engineering structures
- BS EN 60529 Protection provided by enclosures
- BS EN 62305 Protection against lightning. Part 2. Risk management.

A2.5

RETAIL ENERGY CODE COMPANY

- CoMCoP Consolidated metering Code of Practice for meter equipment ~~asset~~ managers and meter installers.

A2.6

ENERGY NETWORKS ASSOCIATION

- GDN/PM/GT2 Gas Distribution Networks' approval document

APPENDIX 3 : DESIGN OF EXPLOSION RELIEFS

The pressure developed in a housing during an explosion is dependent on the weight per unit area of the explosion relief, the method of the relief and the vent area created when the relief operates.

Normally, the explosion relief would be provided by the roof of the housing lifting because, as it forms an integral part of the housing, a lifting roof will not compromise the security of an installation. In addition, this design of relief is intended to re-seat after an explosion and, consequently, operation of such a relief is not to not affect the integrity of a housing. In practice, it is difficult to achieve a satisfactory design of an explosion relief panel which maintains the usual level of security. However, explosion relief panels may be a practical solution where levels of security lower than normal are acceptable or on housings within securely-fenced sites.

For lifting roof explosion relief, the maximum pressure developed during an explosion will be 35 mbar or less provided that:

- the weight per unit area of the lifting roof does not exceed 50 kg m^{-2} . This includes the weight of any part of the roof restraining/guide mechanism that moves with the roof
- the area of the roof that lifts is at least 50% of the total area, i.e. K_{roof} as defined in Figure 5 does not exceed 2
- the height of lift of the roof is sufficient to create a vent area around the perimeter of the roof equal to at least 30% of the total roof area, i.e. K_{lift} as defined in Figure 5 does not exceed 3.3.

In practice, it is anticipated that, in most cases, the whole roof would lift i.e. $K_{\text{roof}} = 1$, and that the height of lift of the roof will be such that the value of K_{lift} will be nearer to unity.

The maximum allowable weight per unit area of 50 kg m^{-2} is adequate to withstand most wind loadings, but is sufficiently low to allow for a snow loading of approximately 30 kg m^{-2} while retaining the effectiveness of the relief.

Ensure the roof restraining mechanism is of an appropriate design, to allow a free vertical movement of the roof to the desired height of lift and minimum lateral movement so that the roof re-seats properly following any explosion. Suitable designs would consist, for example, of a slide rod/guide bracket arrangement or sliding concentric tubes. Firmly attach this restraint/guide mechanism to the four corners of the roof. For a prefabricated housing of steel, concrete or a GRP composite laminate construction, this mechanism may be fixed to either the walls of the building or to the floor. However, for brick-built housings, fix the roof restraint/guide mechanism to the floor.

Hold the lifting roof in place by virtue of the force of gravity only. Do not incorporate devices such as shear pins, spring-loaded latches, etc., which prevent the free vertical movements of the roof, in the roof restraint/guide mechanism.

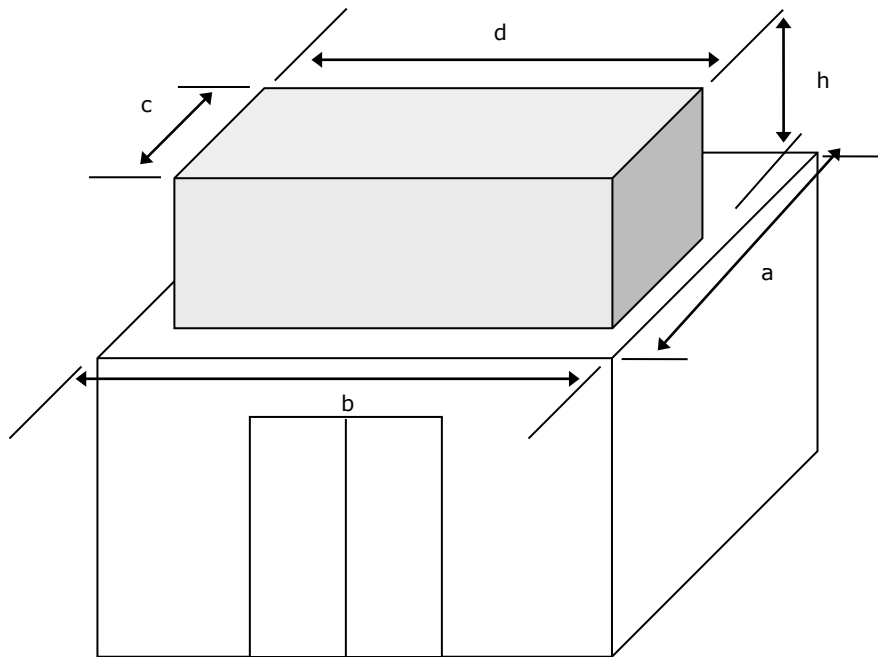

$$K_{\text{roof}} = \frac{\text{Cross sectional area of roof}}{\text{Area of lifting plate}} = \frac{a \times b}{c \times d}$$

$$K_{\text{lift}} = \frac{\text{Cross sectional area of roof}}{\text{Perimeter vent area due to lift}} = \frac{a \times b}{2(d \times h) + 2(c \times h)}$$

FIGURE 5 - EXPLOSION RELIEF ROOF DESIGN

APPENDIX 4 : PERFORMANCE TESTS FOR GRP HOUSINGS

A4.1 TEST CONDITIONS

Unless otherwise specified, carry out the tests at an ambient temperature of $20^{\circ}\text{C} \pm 5^{\circ}\text{C}$.

For a prefabricated sandwich specimen, expose the core material of panels on all four edges.

A4.2 Sequence of testing

- a) Soak tests A4.3
- b) Temperature cycling test A4.4
- c) Impact testing A4.5.

A4.3 Soak test

Immerse two specimen panels of 1.0 m square in a vertical plane in clean still water of pH 7 ± 0.5 at $20 \pm 5^{\circ}\text{C}$ for a period of 14 days. Ensure the position of the panels allow water access to all surfaces and edges.

Check the housing material does not suffer any visible or measurable degradation of the material.

A4.4 Temperature cycling test

Cycle two specimen panels of 1.0 m square from ambient temperature to $-20 \pm 2^{\circ}\text{C}$ in a period not less than 12 hours. Hold the temperature at $-20 \pm 2^{\circ}\text{C}$ for a period of 12 hours.

Cycle the specimen panels from -20°C to $+20 \pm 2^{\circ}\text{C}$ in a period not less than 12 hours, and hold at $20 \pm 2^{\circ}\text{C}$ for a period of 12 hours.

Cycle the specimen panels from 20°C to $50 \pm 2^{\circ}\text{C}$ in a period not less than 12 hours, and hold at $50 \pm 2^{\circ}\text{C}$ for a period of 12 hours.

Allow the panels to cool to ambient temperature.

Repeat the above temperature cycle a further three times.

Check the housing material does not suffer any visible or measurable degradation of the material.

A4.5 IMPACT TEST

Freely support a specimen panel of 1.0 m² along all four edges in a horizontal plane. Drop the steel impact tool (see Figure 6) of mass 4.5 kg from a height of 1 m so that it strikes the centre of the panel.

Repeat this test with a panel that has undergone and passed the soak test.

Repeat this test with a panel that has undergone and passed the temperature cycling test.

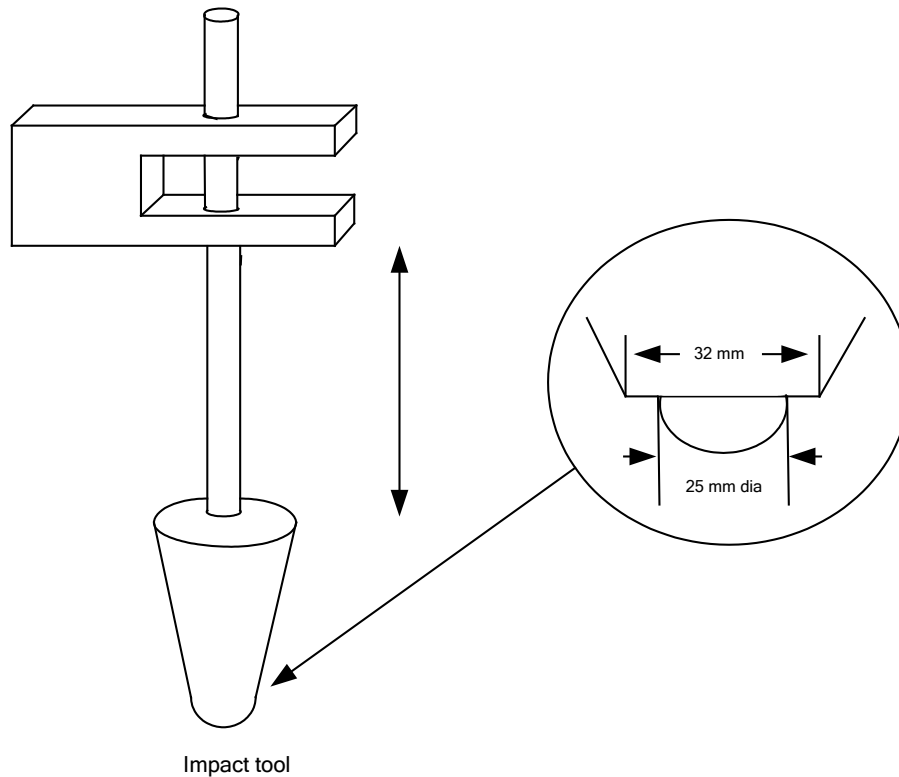

FIGURE 6 – IMPACT TOOL

Check the housing material does not suffer any visible or measurable deformation or cracking of the material.

Moulded housing material comprising of single skin GRP may suffer a starcrack of maximum crack length of 2 mm from the point of impact without delamination. Ensure the crack does not penetrate more than 1 mm into the surface of the material.

A4.6

SOFT BODY IMPACT TEST

Erect a specimen wall panel vertically and support in a frame.

Test the panel using the apparatus and procedures detailed in BS EN 596.

Ensure the point of impact is at the centre of the panel.

Check the housing material does not suffer any visible or measurable deformation or cracking of the material.

BLANK PAGE